

Test Bench Trials of the Electromagnetic Regenerative Shock Absorber

Kireev A.V.^{1,a}, Kozhemyaka N.M.^{1,b}, Burdugov A.S.^{1,c} and Klimov A.V.^{2,d}

¹ Scientific and Technical Center "PRIVOD-N", Novocherkassk city, Krivoshlykova st. 4a, Rostov region, Russian Federation.

² KAMAZ Innovation centre Ltd, Russian Federation, Moscow.

^aOrcid: 0000-0003-1157-2402, ^bOrcid: 0000-0002-3976-7546

^cOrcid: 0000-0002-8405-7092, ^dOrcid: 0000-0002-5351-3622

Abstract

The article sets forth the design of the electromagnetic regenerative shock absorber for suspension system of the long haul tractor truck with regeneration of mechanical energy produced by oscillations of the spring loaded mass into electric power. It describes the structure of the test bench to test the designed shock absorber. Results of the experimental tests are given.

Keywords: Electromagnetic regenerative shock absorber, ball-screw, permanent magnet synchronous machine.

INTRODUCTION

The task of improving the cost-efficiency of motor vehicle transport, including vehicles powered by electric drive, has been becoming ever more topical and has continued to be in the focus of attention of the foremost vehicle manufacturers. One of the possible solutions is to design a suspension system based on the regenerative shock absorber. The mechanical energy generated by the body oscillations is converted to electric power using an electro-mechanical transducer (generator), integrated into the design of the shock absorber. The energy thus produced is utilized to charge the on-board storage battery. Apart from the function of energy regeneration, such a shock absorber is supposed to provide a force of resistance in case of jounce and in case of rebound depending on the speed of the shock absorber rod travel similar or close to the conventional hydraulic shock absorber.

At present time, there are a number of regenerative shock absorbers designs based on electro-mechanical generator. They can be divided into two groups depending on the type of the generator used to convert mechanical energy into electric power: based on the linear generator and based on rotational generator.

A linear inductor machine [1, 2] or permanent magnet synchronous machine [3, 4] can be used as the linear generator. The advantage of the shock absorber with the linear generator is direct conversion of reciprocating motion into electric power without the intermediate mechanical conversion. This is important given great dynamic loads acting on the shock absorber when driving on the road bumps.

However, road tests go to show that travel on asphalt at different speeds causes the shock absorber rod to shift with body oscillations by 5÷10 mm [5]. Given such a small shift, it is possible to put the inductor machine into generative mode, if the size of the translator tooth is also small enough. This makes the design of the shock absorber much more complex. Besides, the shock absorber based on linear generator in the overall dimensions of serially produced hydraulic shock absorber is not capable of providing the damping characteristic in case of rebound at the rod speeds up to 0.3 m/s due to negative influence caused by the winding active resistance.

Use of rotational generator [6, 7] makes it possible to reduce the negative effect of active resistance at low speeds of the rod travel. Mechanical conversion of linear motion into rotation using the ball-screw drive and use of multi-pole stator allows acceptable indicators to be achieved as a result of increasing rpm of the rotational generator at low speeds of the rod.

MATERIALS AND METHODS

Figure 1 shows the regenerative shock absorber for suspension system of a truck based on the rotational generator with ball-screw drive. Overall dimensions and connection dimensions correspond to the serially produced shock absorbers of the long haul tractor truck with an axle load between 4500 and 11500 kg.

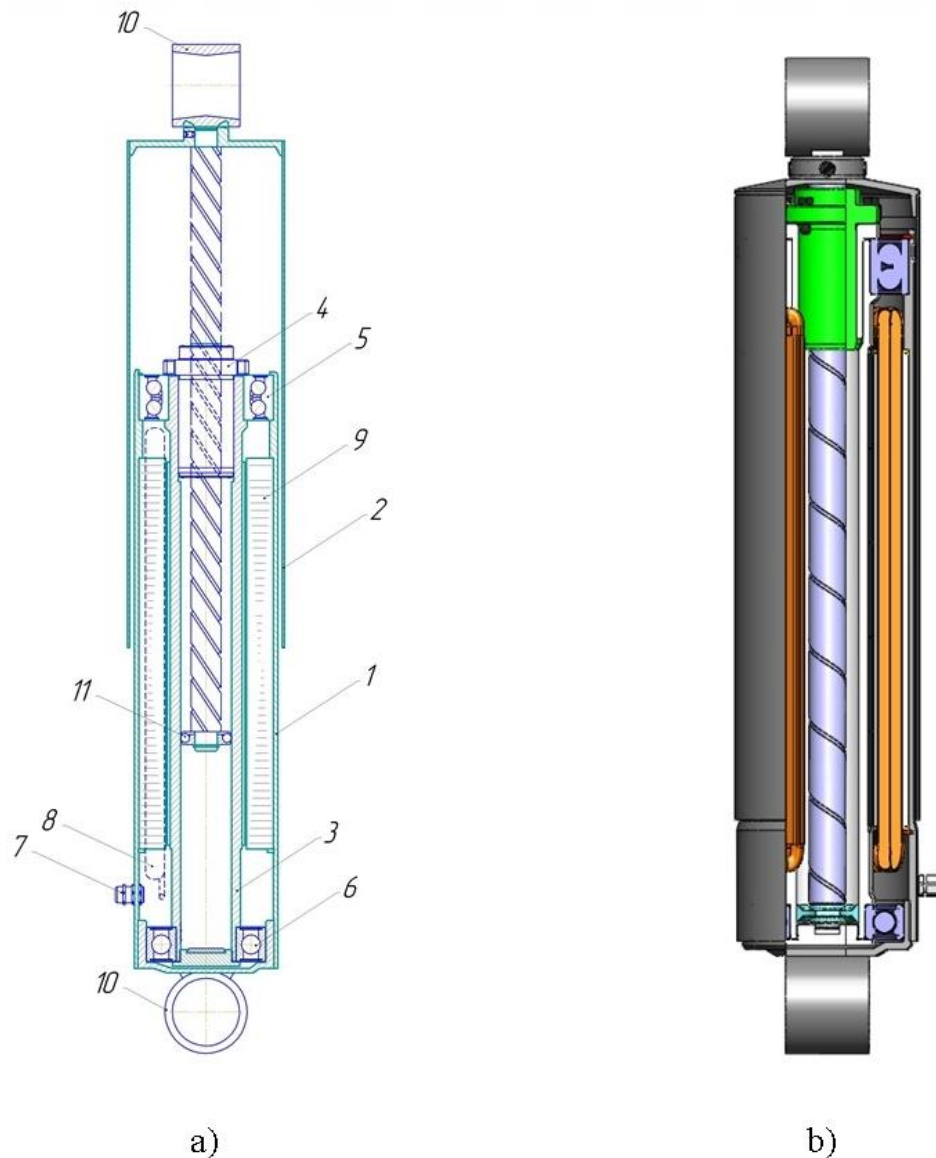

Figure 1: Design of regenerative shock absorber

(a) – cross section, (b) – 3D model

1– inner tube, 2 – outer tube, 3 – rotor, 4 – ball-screw, 5 – radial thrust bearing, 6 – ball bearing, 7 – cable gland, 8 – stator winding, 9 – stator, 10 – mounting bush, 11 – ball bearing

The screw rod which is part of the ball-screw drive is attached on the inner tube of the shock absorber; the ball-screw drive nut is attached to the inner tube using bearings. The reciprocating motion of the rod is converted into rotation of the rotor attached on the ball-screw drive nut. The screw rod moves inside the rotor. Permanent magnets are fixed on the rotor surface. Three phase winding is installed in the stator slots. Stator winding induces electromotive force at the rotor turns, thus converting the mechanical energy of the shock absorber’s reciprocating motion into electric power. The winding is placed into the slots in the “star” scheme. Each phase consist of eight coils connected in series.

As the shock absorber operates, the generator produces alternating three phase voltage which is rectified and stabilized as a definite level required charging the drive battery of a vehicle or of any other energy storage.

In order to create the required rebound and jounce force of the shock absorber, the control system has to regulate the generator’s electric load depending on the rod direction and the rod speed. The rod direction is determined by controlling the generator phase alternation, whereas the speed is calculated based on the generated voltage frequency. These functions have been implemented in the shock absorber control unit. The regenerated energy in the regenerative shock absorber supplied the charger and is utilized to charge the vehicle battery.

Figure 2 illustrates the structure of the test bench for testing of the regenerative shock absorber. The rack with sensors is a steel framework with linear guide ways for vertical movement of the shock absorber rod. The rack contains a force sensor and a laser motion sensor. The motor is connected with the

rack using the crank and connecting rod mechanism with adjustable crank length. By changing rotation speed of the motor and the crank radius on the motor disk, the required rod speed and the shock absorber rod stroke are set.

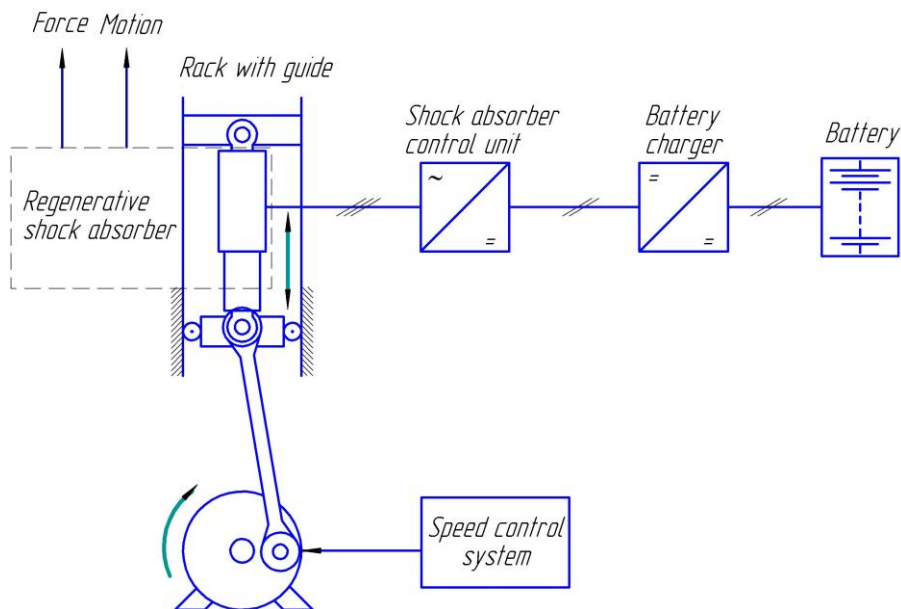

Figure 2: Structure of the test bench for shock absorber tests

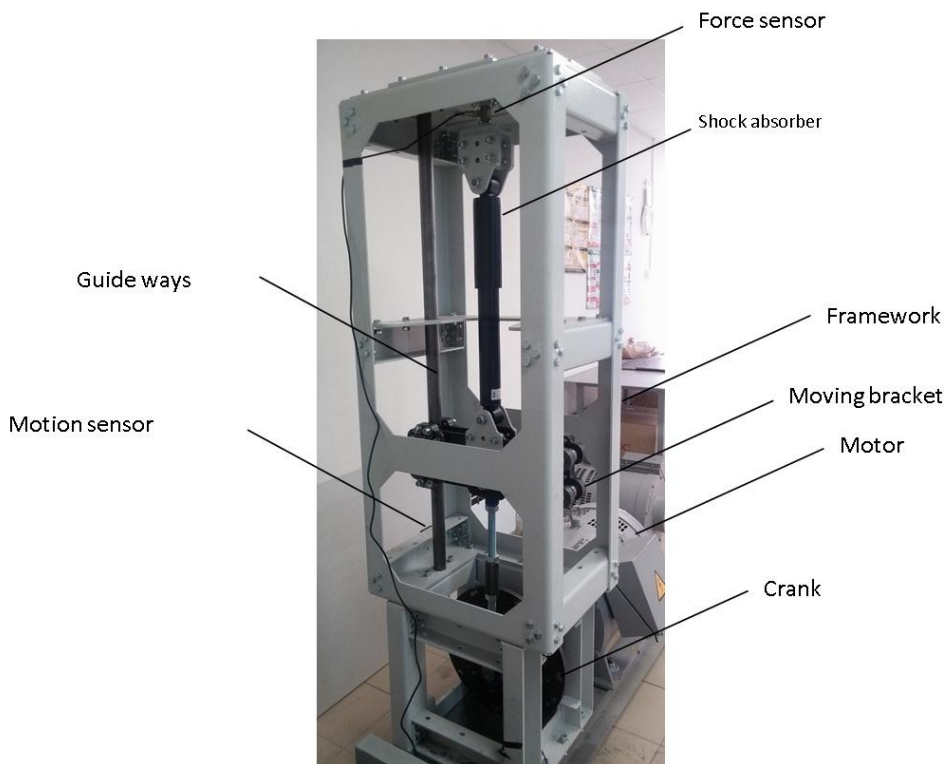

Figure 3: Test bench for shock absorber test

As the motor shaft rotates, the crank drives the moving bracket, moving along the linear guide ways, to which the lower fixation point of the shock absorber is connected. The laser motion sensor mounted on the bracket. The upper fixation point is connected to rack frame via a force sensor. A photo of the rack is shown in Figure 3.

The measuring system of the test bench records the signals from the force sensor and the motion sensor, phase currents and voltages of the shock absorber, output current and voltage of the shock absorber control unit, output current and voltage of the charger. This enables to calculate the regenerative pow-

er at different speeds of the shock absorber, and to get dependence of the jounce and rebound force versus the rod speed.

EXPERIMENTAL RESULTS

In one turn of the test bench motor shaft, the shock absorber undergoes the jounce and the rebound phase. The rod speed, at the same time, changes from zero to maximum following the law close to the sinusoidal one (figure 4).

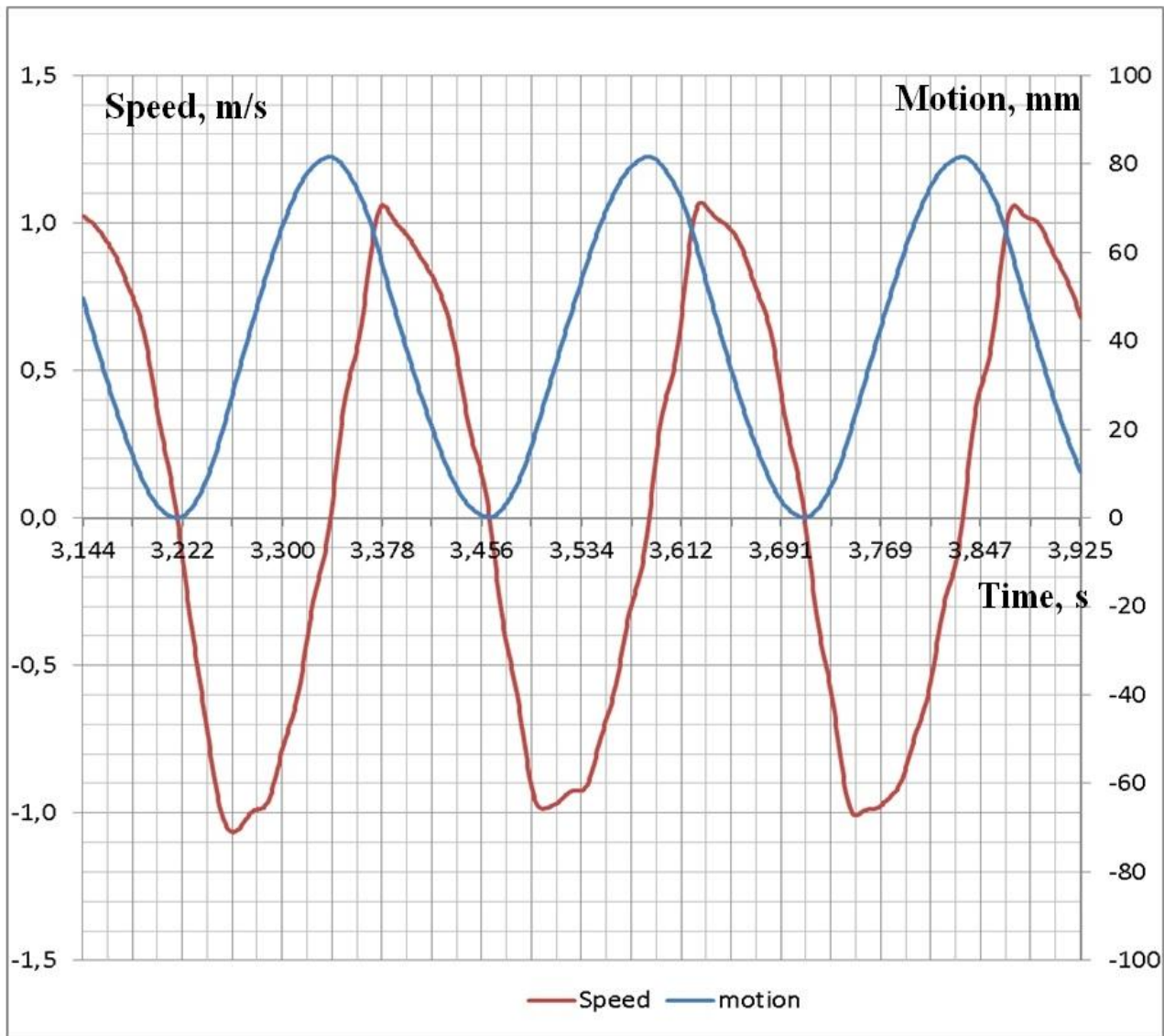

Figure 4 – Speed and motion of the shock absorber rod

Figure 5 shows phase currents and linear voltages of the shock absorber generator, the rod speed and output power of the generator. The regenerative power at the rebound phase with

the rod speed of 1 m/s reaches 2.1 kW, at the speed of 1.5 m/s, it is 3 kW. Average power per one turn of the crank amounted to 1.27 kW.

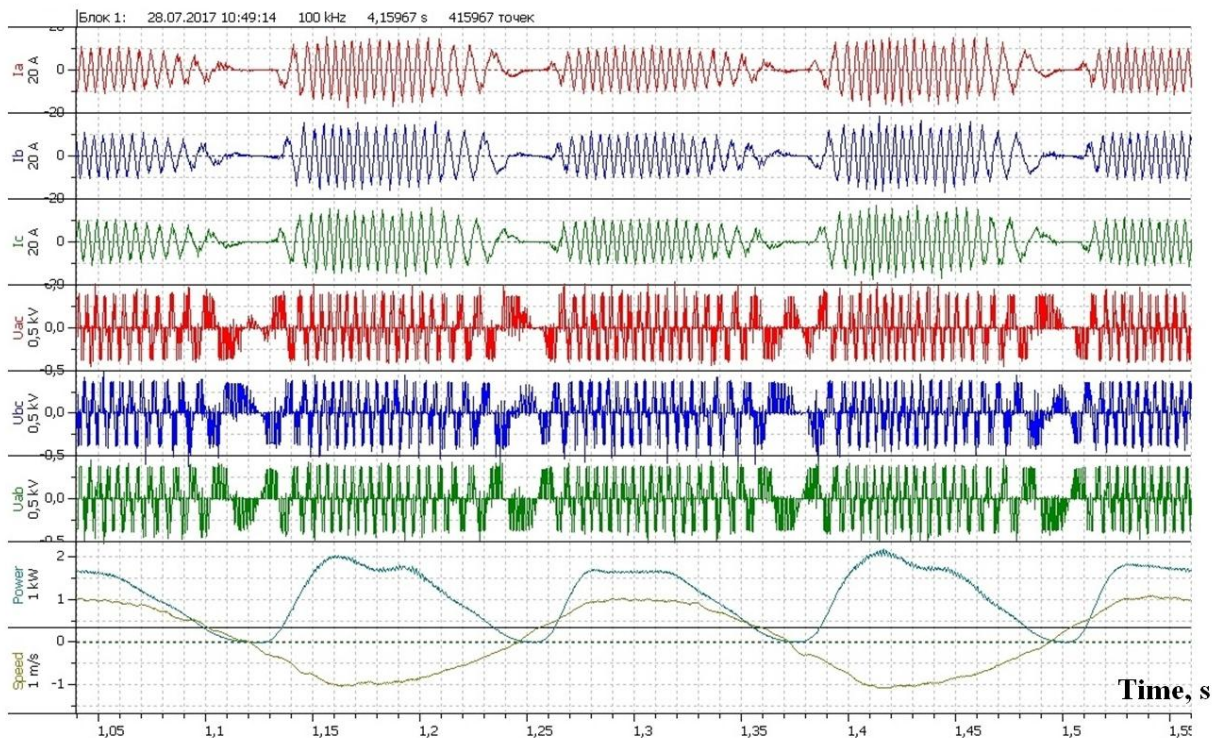

Figure 5: Currents, voltages and power of the shock absorber at different rod speeds

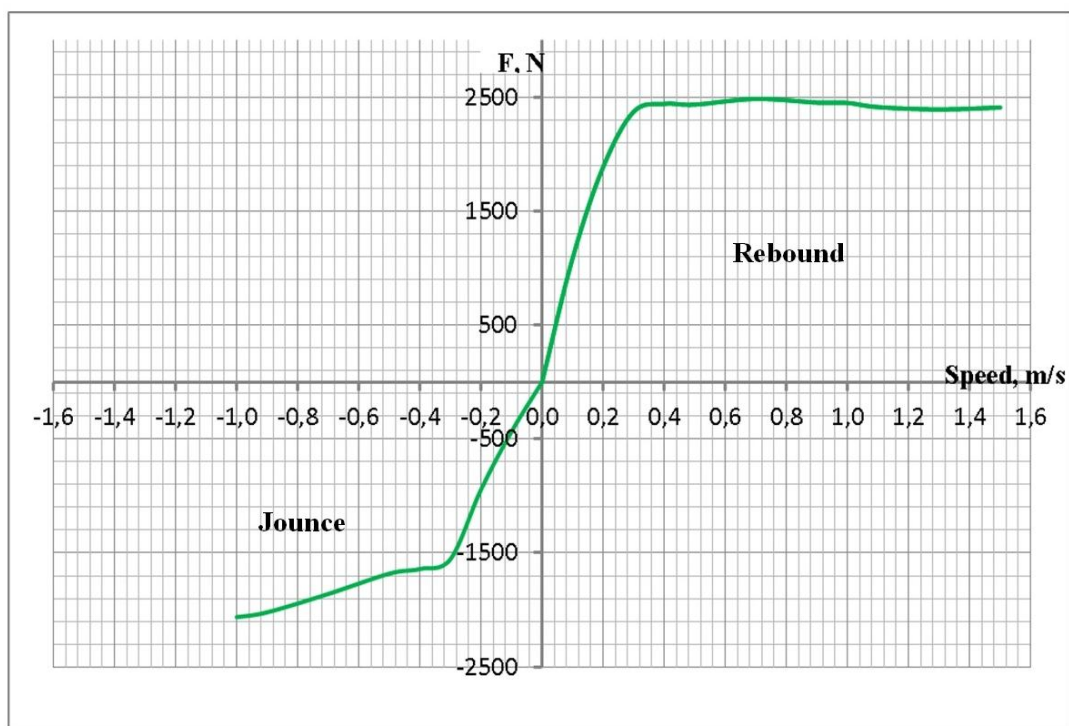

Figure 6: Shock absorber force versus rod speed

Based on the test data, the dependence of the shock absorber force on the rod speed (Figure 6) has been plotted. The control system, depending on the rod stroke direction (jounce or rebound), establishes different forces which resist the motion of the vehicle's suspended mass.

CONCLUSION

This article presents the regenerative shock absorber, which contains a synchronous generator with permanent magnets. To convert reciprocating motion of the rod into rotation of the generator, the ball-screw drive is used. The speed and direction of the rod travel are determined based on the generator phase alternation and based on the frequency of the generated voltage. This allows to avoid using speed and motion sensors in the shock absorber control system. The regenerative power of up to 3 kW and a force of up to 2500 N have been obtained during experimental test on the test bench.

ACKNOWLEDGEMENTS

The presented work has been developed with support of Russian Ministry of Education, grant RFMEFI57915X0124.

REFERENCES

- [1] Popa, D., Szabó L., Gliga V., 2013. "Theoretical and experimental study of a modular tubular transverse flux reluctance machine". *Progress in Electromagnetics Research*, Vol. 139, pp. 41-55.
- [2] Zhang, Z., Cheung N. C., Cheng K. W. E., 2010 "Application of Linear Switched Reluctance Motor for Active Suspension System in Electric Vehicle". *World Electric Vehicle Journal* Vol. 4 - ISSN 2032-6653, WEVA, pp. 14-21.
- [3] Oprea, C. A., Martis C. S., Jurca F. N., Fodorean D., Szabó L., 2011. "Permanent Magnet Linear Generator for Renewable Energy Applications: Tubular vs. Four-Sided Structures". *Clean Electrical Power (IC-CEP)*, 2011 International Conference on, E-ISBN 978-1-4244-8928-2, pp. 588-592.
- [4] Gysen B.L.J., Paulides J.J.H., Janssen J.L.G., Lomonova E.A., 2010, "Active Electromagnetic Suspension System for Improved Vehicle Dynamics", *IEEE Transactions on vehicular technology*, Vol. 59, No. 3, pp. 1156-1163.
- [5] Kireev A.V., Kozhemyaka N.M., Burdugov A.S., Nazarenko S.V., Klimov A.V., 2016. Review on electromagnetic energy-regenerative shock absorbers. *Journal of Engineering and Applied Sciences*, Vol. 11, pp: 2551-2556.
- [6] Li Z., Zuo L., Luhrs G., Lin L., Qin Y., 2013, "Electromagnetic Energy-Harvesting Shock Absorbers: Design, Modeling, and Road Tests", *IEEE Transactions on vehicular technology*, Vol. 62, No. 3, pp. 1065-1074.
- [7] Zuo L., Scully B., Shestani J., Zhou Y., 2010, "Design and characterization of an electromagnetic energy harvester for vehicle suspensions", *Smart Materials and Structures*, №19, pp. 1-11.