

Implementation 3-Axis CNC Router for Small Scale Industry

R.Ginting¹, S. Hadiyoso² and S.Aulia³

^{1,2,3}Telkom Applied Science School, Telkom University, Indonesia.

²Orcid: 0000-0002-2086-2156

Abstract

This paper discusses the design and realization of complex 3-axis CNC machines based on microcontroller which combined with spindle drill. This machine can be used for Cutting, Engraving and Marking on wood, acrylic and PCB objects. Design picture that have been made on the PC sent to the microcontroller using serial communication then CNC perform execution on object according to point coordinates. Drill spindles will create patterns on objects automatically according to the design drawings. After testing, the CNC machine can be used for cutting, engraving and marking on wood, acrylic and PCB to 2D or 3D objects with 98.5% of carving accuracy and 100% of depth accuracy. This machine works on a object with maximum size of 20 x 20 cm.

Keyword: CNC, Microcontroller, Cutting, Engraving, Marking

INTRODUCTION

Working with automatic mechanical equipment demands precise, accuracy, speed, consistency and flexibility. In this case it takes the help of embedded computer applications to do the job. One of the mechanical equipment combined with microcomputer that has been widely used is a CNC machine (Computer Numerically Controlled). CNC machines are used for mechanical work such as cutting, engraving, drilling and others. The computer technology used to control, parse and execute [1] certain objects based on user command. In the manufacturing industry, the use of CNC machines greatly affects the increased production [2][3].

In Indonesia, CNC machines have not been developed so that they are imported directly from other country. This has an impact on the industry that is difficult to develop because the price of CNC machines still expensive. The challenge is how to make CNC machines with good performance but low cost so that it can contribute to the acceleration of domestic manufacture industry.

CNC machines are popular and widely used in the industry is a CNC that can form objects on acrylic, glass, wood and plate, mostly using laser, knife, or drill as cutting media. Research on the manufacture of CNC machines and fundamentals of

embedded algorithms with the aim of producing high performance CNC machines with low cost has been widely practiced. Research about realization of low cost CNC machine by Jayachandraiah [3], discusses the development of a low cost 3-Axis CNC router. This research [3] is main literature review on hardware dan mechanic design. Research by Paulo [1], realizes a 3 axis CNC machine as well as a LabVIEW-based application program as an instruction giver. The paper does not specifically specify the use of the CNC machine. Other realization of CNC machine by Ali [4], present a controlling system for CNC machines to mill and drill PCB board also performed by [5-7]. Object of PCB result of milling and drill and detail of test result not shown in paper. Research on the development of algorithms for CNC machine control by Desai [8], in his paper discussed the development of algorithms for interpreters and interpolators and then tested on CNC machines for linear as well as circular interpolation.

Other fundamental research by Awari [9], conducted a study for the Selecting parts for low cost CNC milling machines that can be used in Small Scale Industry. The realization of CNC machines by Pawar [10] to draw objects. The main purpose of this work is to make efficient, reduce errors, and also increase the accuracy of the production. However in that paper has not been discussed in detail these parameters.

From the review of the studies described above can be concluded that research on CNC both hardware manufacture and algorithm development is active in order to produce a good performance CNC machine but still at a low cost. Therefore in this paper is discussed a design of cheap 3-axis router CNC machine based on microcomputer as its main control. In this CNC machine mounted spindle drill that can move automatically by stepper motor. This CNC router machine can be used as a tool to form 3-dimensional objects such as cutting, engraving, marking on wooden, acrylic and PCB objects. This paper also discussed in detail the results of testing the CNC performance parameters.

RESEARCH METHOD

The first step in the operation of CNC machine was calibrating the tool, it was aimed to know whether the stepper motor and any other system were working according to the program that has been configured. Followed by setting the

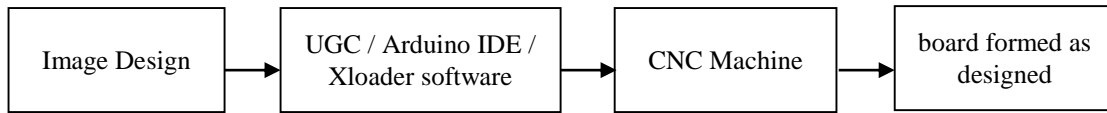

Figure 1: Block diagram of CNC machine design

starting position of the spindle drill on the CNC machine using *Universal Gcode Sender* software both automatically and manually by hand spinning. Spindle drill speed can be set up to a maximum speed of 12000 rpm (rotation per minute). After the CNC machine is calibrated, the design with the *.gcode extension format was uploaded using *Universal Gcode Sender* to *Arduino Uno* with serial communication. The microcontroller will read the data as a command and provide logic to the *A4988* motor driver. The data received by the motor driver was used to drive 3 *Nema 17* X, Y and Z axis stepper motors, so that a pattern will be formed on the object

according to the design. The whole system block diagram that has been designed is shown in Figure 1.

Mechanical Design :

The main tools in mechanical design consist of multiplex board, stepper motor, linear bearing, ball bearing, linear shaft, leadcrew and nut, coupling beam, power supply and spindle drill. Figure 2 is a 3D design of CNC machine made using AutoCad software.

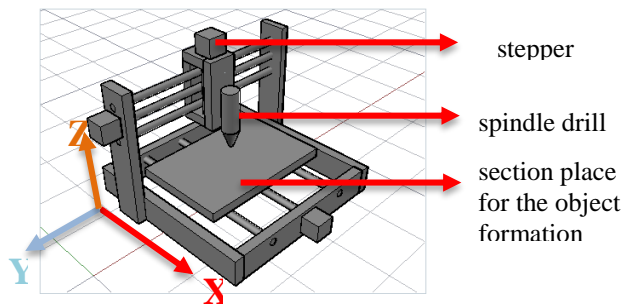

Figure 2: CNC machine viewed from top left corner

Electronic Design:

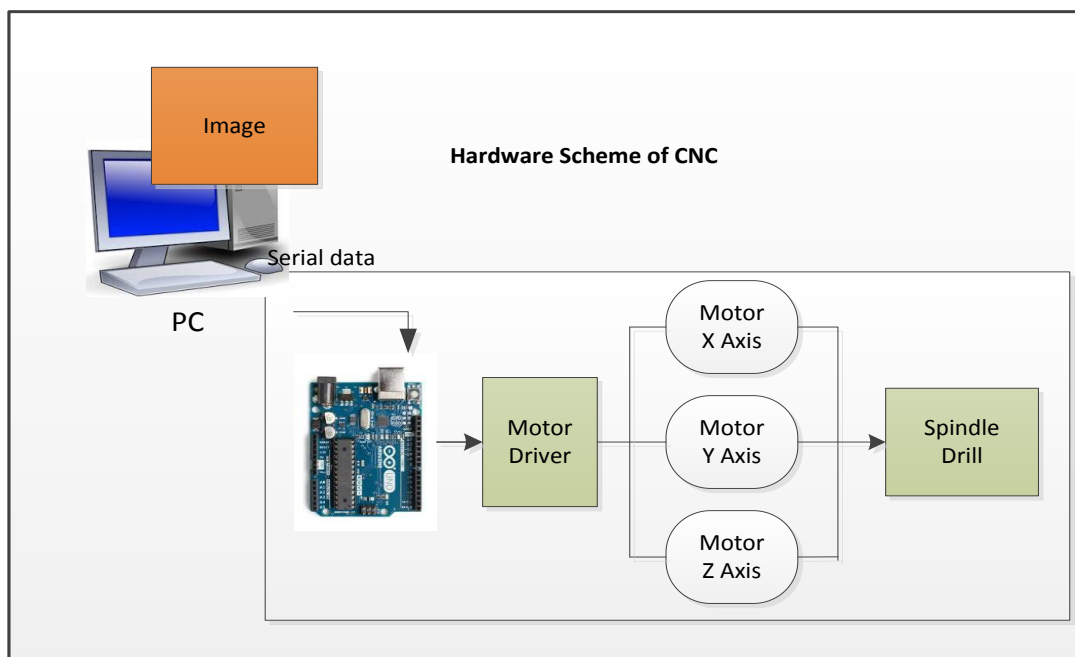

Figure 3: Block diagram of electronic design of CNC machine based on microcontroller with some supporting softwares

The electronic system used on microcontroller based CNC machine was the power supply which used as a voltage source on personal computers and CNC machine. Personal computer was used as a device to run some software such as *Xloader*, *Universal Gcode Sender*, and *Arduino IDE*, also to send design file to *Arduino Uno* microcontroller using serial communication. 12V 10A power supply was used as a voltage source for *A4988* driver motor to run the 3 *Nema 17* stepper motors which controlled by *Arduino Uno* microcontroller, and 12V fan voltage source was used as a driver motor and

Arduino Uno cooler to avoid overheating that could damage the component. 48V 10A power supply was used as a voltage source for spindle drill, the voltage that goes into the spindle drill was set using a motor controller. The 3 *Nema 17* stepper motors will move the spindle drill in the direction of the X, Y and Z axes, so that the object can be formed in the wood board according to the design. Display of microcontroller based CNC machine that has been built can be seen in Figure 4.



(a) (b) (c) (d)
Figure 4: CNC machine display. (a)Front view (b)Back view (c)Corner right view (d)Top view

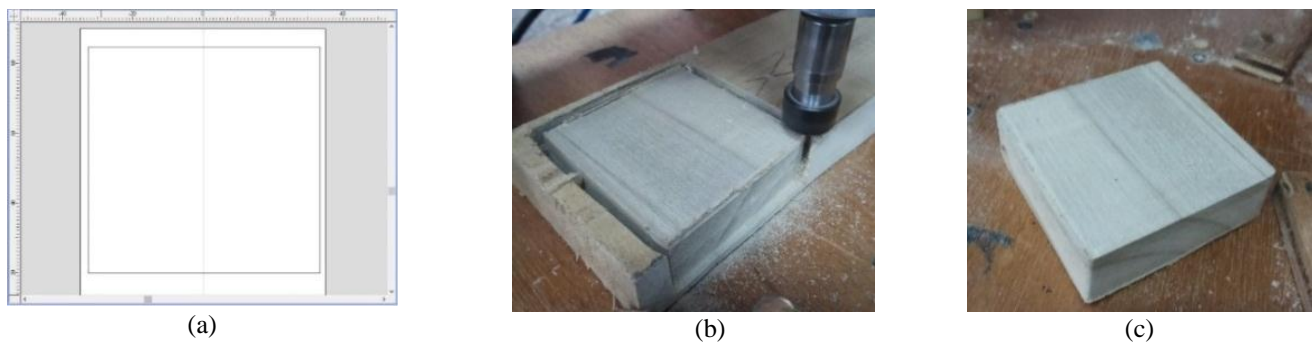

(a) (b) (c)
Figure 5: (a)Image design. (b)Cutting process. (c) Cutting result.



(a) (b) (c) (d)
Figure 6: (a)Image design. (b)Engraving process. (c)Engraving result. (d)Engraving result.

The followings are the specification of microcontroller based CNC machine that has been built:

Dimension (XYZ)	: 33,5x31x44cm
Cross sectional area	: 26x26cm
Workspace area	: 20x20cm
Material	: Multiplex board 12mm
Spindle drill	: Air cooled 500 Watt
Stepper motor	: Nema 17 12V 1,7A
Driving system	: Leadscrew 8mm
Controller	: Arduino Unomikrokontroller
ATMega328p	
Driving motor	: IC A4988polulu
Function	: cutting, engraving,and marking
Supply	: 220V /50-60Hz
Interface	: USB port
Software	: Universal Gcode Sender, Xloader and Arduino IDE

RESULTS AND ANALYSIS

To be able to test the CNC machine in doing cutting, engraving and marking into the wood board, the first step that must be prepared was making the design form. Then prepare the wood board in size of the design form and then clip above the CNC machine cross section so it won't change position during the workmanship. Upload the design using *Universal Gcode Sender* software into the *Arduino* using serial communication.

Cutting System Test

Cutting is a technique for cutting wood using a drill bit with a shape according to the design. The cutting system was tested on a wood with 20mm thickness, using 3mm *endmill* drill bit, 12000 rpm spindle speed and 20mm cutting depth. Image design using *Vetric Aspire 8.5* software, design example is a square shape with 6x6cm width. Cutting test process can be seen in Figure 5.

EngravingSystem Test

Engraving is a technique of carving on wooden material surface with different depths, so images or letters can be recognized. The engraving system was tested on a wood with 20mm thickness, using 3mm *vbit 60°* drill bit, 12000 rpm spindle speed and 7mm engraving depth. Image design using *Vetric Aspire 8.5* software, design examples using writing combined with engraving pattern. Engraving test process can be seen in Figure 6.

Marking System Test

Marking is a technique of carving on material surface with the same thin depths. Usually marking was used to put a mark or a brand on a metal or a non metal material. The marking

system was tested on a wood with 20mm thickness, using 3mm *vbit 60°* and *endmill* drill bit, 12000 rpm spindle speed and 1mm and 0.5mm marking depth. Image design using *Vetric Aspire 8.5* software, sample design using writing combined with carving pattern. In addition to wood, the marking also tested on a PCB to create the electronic circuit as shown in Figure 7.



Figure 7. (a) Marking result on wood board. (b) Marking result on PCB.

3.4 Accuracy Test

The accuracy test was conducted to determine the level of precision of CNC machine in making shape. This test input was a 6 lines design with 50mm length, which will be formed on a wood with 1mm depth. using 3mm *vbit60°* drill bit, with 12000 rpm spindle speed.

Table 1: Accuracy Test

Line No	Design	Measurement Result	Accuracy (%)
1	50 mm	50,5 mm	99%
2	50 mm	51 mm	98%
3	50 mm	50,5 mm	99%
4	50 mm	50,5 mm	99%
5	50 mm	51 mm	98%
6	50 mm	51 mm	98%

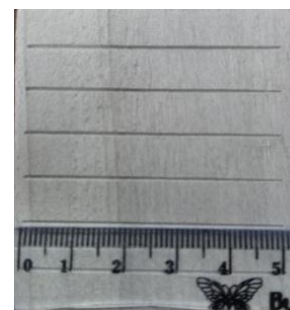

Figure 8. Accuracy Measurement

From testing result on Table 1, it was obtained a test result in a form of 6 lines with 50,75mm length in average and 98.5% accuracy level.

Depth Measurement

The measurement was conducted to determine the level of precision on the depth of CNC machine when working. Testing in Figure 8 was creating 7 lines each of which has 5cm length and 2mm depth using a 3mm *endmill* drill bit with a spindle speed of 12000 rpm.

Table 2: Depth measurement

Line No	Depth in design	Measurement Result
1	2mm	2mm
2	2mm	2mm
3	2mm	2mm
4	2mm	2mm
5	2mm	2mm
6	2mm	2mm
7	2mm	2mm

Table 2, shows that the line carving produced by the CNC machine with 2mm depth has a precision accuracy of 100%.

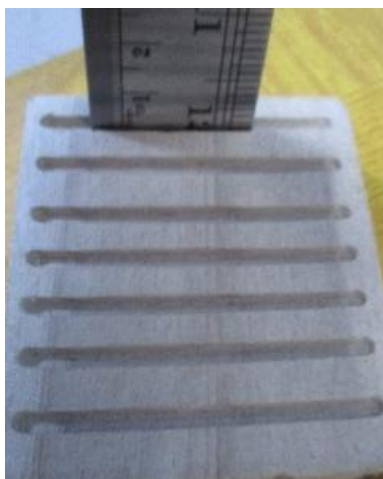

Figure 9: Depth Measurement

Speed Test

The speed test was conducted to determine the effect of angle on the speed in the object formation. The input for this test was a line design with 10cm length which will be formed to resemble some 2D shape. With 1mm engraving depth on wood using 3mm *endmill* drill bit. Uploaded designs will be timed using a stopwatch to see how long it takes for each design to be made.

Table 3: Speed Test

No	Design	Time (s)
1	Line	7,1
2	Circle	10,9
3	Triangle	10,5
4	Square	12,2
5	Rectangle	13,4
6	Pentagon	13,5
7	Hexagon	13,6
8	Heptagon	13,7
9	Octagon	15,2
10	Nine facet	15,4

Table 3 shows that there is a time variation for the engraving process on a wide range of 10cm length 2D shapes. From the 10 tests in Table 3, it can be deduced that the more angles in the formation of the object will slow down the work process, because the X, Y and Z axes on CNC machine move more simultaneously resulting in slower movement of the axis.

CONCLUSION

The CNC router machine was successfully built using *ATmega328p* and *IC4988* microcontrollers combined with 3 *Nema 17* stepper motors, with 20x20cm cross-sectional area and using 500 Watt *Spindle Air Cooled* drill type. The CNC machine can be used for cutting, engraving and marking on wood to form 2D or 3D objects with 98.5% carving accuracy and 100% depth accuracy. The process of synchronizing the 3 stepper motors was controlled using *GRBL library* and *Universal Gcode Sender Software*.

REFERENCES

- [1] Paulo, Rogério, and Maria., 2010, "Prototype CNC Machine Design," International Conference on Industry Applications.
- [2] Widarto., 2008, "*Teknik Pemesinan*. Jakarta: Direktorat Pembinaan Sekolah Menengah Kejuruan,".
- [3] B. Jayachandraiah, O. V. Krishna, P. A. Khan, and R. A. Reddy., 2014, "Fabrication of Low Cost 3-Axis Cnc Router," *Int. J. Eng. Sci. Invent.*, vol. 3, no. 6, pp. 1–10.
- [4] M.A.A. Ali, A.M.A. ELShaikh, and S.F. Babiker., 2016, "Controlling the CNC Machine using Microcontroller to

Manufacture PCB,” Conference of Basic Sciences and Engineering Studies (SGCAC), pp. 116-120.

- [5] K.J.Madekar, K.R.Nanaware, P.R. Phadtare, V.S. Mane., 2016,“Automatic mini CNC machine for PCB drawing and drilling,” International Research Journal of Engineering and Technology (IRJET), vol. 3, issue: 2, pp. 1106-1110.
- [6] R. Basniak and M.F. Catapan., 2012,“Design of A Pcb Milling Machine,” ABCM Symposium Series in Mechatronics, Vol. 5, pp. 1339-1348.
- [7] C.F. Wise., 2007, “Fabrication of Printed Circuit Boards Using a Table Top CNC Mill,” *the Technology Interface/Fall 2007 Wise*
- [8] D.P. Desai and D.M. Patel., 2015,“Design of Control Unit for CNC Machine Tool using Arduino based Embedded System,” International Conference on Smart Technologies and Management for Computing, Communication, Controls, Energy and Materials (ICSTM), pp. 443-448.
- [9] D. Awari, M. Bhamare, A. Ghanwat, K. Jadhav, and J. Chahande., 2017,“Methodology for Selecting Components for Fabricating CNC Milling Machine for Small Scale Industry,” International Journal for Scientific Research & Development, Vol. 4, Issue: 11, pp. 168-171.
- [10] A.S. Pawar, M.J. Halunde, S.M. Nayakawadi, and Ms. P. P. Mirajkar., 2017, “3 AXIS DRAWING MACHINE,” International Research Journal of Engineering and Technology (IRJET), vol. 04 Issue: 03, pp. 693-697.