

Mathematical Analysis of SVPWM for Inverter fed DTC of Induction motor Drive

V. Raveendra Reddy¹ and Dr. V.C. Veera Reddy²

Research scholar, Associate professor, Department of Electrical and Electronics Engineering, RamiReddy Subbarami Reddy Engineering College, Kadanuthala, NH-5, S.P.S.R. Nellore District, Andhra Pradesh, India.

Orcid Id: 0000-0001-9942-0889

²Professor, Department of Electrical and Electronics Engineering, Annamacharya Institute of Technology & Science, Tirupati, Andhra Pradesh, India.

Abstract

Various aspects related to controlling induction motors are investigated. The direct torque control (DTC) strategy is studied in details and its relation to space vector modulation (SVM) is emphasized. In this paper, the simulation analysis of space vector pulse width modulated (SVPWM) inverter fed induction motor drives is presented. The main objective of this paper is the analysis of induction motor with SVPWM fed inverter and harmonic analysis of voltages & current. For control of IM, number of pulse width modulation (PWM) schemes are used for variable voltage and frequency supply. The most commonly used PWM schemes for three-phase voltage source inverters (VSI) are sinusoidal PWM (SPWM) and space vector PWM (SVPWM). There is an increasing trend of using space vector PWM (SVPWM) because it reduces harmonic content in voltage, increases fundamental output voltage of IM. So, here the performance of SVPWM inverter fed induction motor drive is modeled and simulated using MATLAB/SIMULINK software. The results of SVPWM based speed control of induction motor drive are compared with the results of pulse width modulator (PWM) controlled induction motor (IM) drive and direct torque (DTC) controlled induction motor drive.

Keywords: Voltage Source Inverter (VSI), Sinusoidal Pulse Width Modulation (SPWM), Space Vector Pulse Width Modulation (SVPWM), Direct Torque Control (DTC), Induction Motor (IM)

INTRODUCTION

The Induction Machine (IM) has been widely used in industries due to its relative cheapness, low maintenance and high reliability [1]. The control of IM variable speed drives [2],[3] often requires control of machine currents, which is achieved by using the Voltage Source Inverter (VSI). In conventional DTC, electromagnetic torque and flux are independently controlled by selection of optimum inverter switching modes. The selection of optimum inverter switching modes is made to limit the electromagnetic torque and flux linkage errors within the torque and flux hysteresis bands. The basic DTC scheme consists of two comparators with specified bandwidth, switching table, voltage source inverter, flux and torque estimation block. Like every control method has some advantages and disadvantages, DTC method has too. Some of

the advantages are lower parameters dependency, making the system more robust and easier to implement and the disadvantages are difficult to control flux and torque at low speed, current and torque distortion during the change of the sector, variable switching frequency, a high sampling frequency needed for digital implementation of hysteresis controllers, high torque ripple. The torque ripple generates noise and vibrations, causes errors in sensorless motor drives, and associated current ripples are in turn responsible for the EMI. The reason of the high current and torque ripple in DTC is the presence of hysteresis comparators together with the limited number of available voltage vectors. If a higher number of voltage vectors than those used in conventional DTC is used, the favorable motor control can be obtained. Because of the complexity of power and control circuit, this approach is not satisfactory for low or medium power applications. Another solution to minimize torque ripple is the space vector modulated DTC.

IMPLEMENTATION OF SPACE VECTOR PWM (SVPWM)

To understand the SVM theory, the concept of a rotating space vector is very important. The concept of space vectors is derived from the rotating field of AC machine which is used for modulating the inverter output voltage. In this modulation technique, the three phase quantities can be transformed to their equivalent 2-phase quantity either in a synchronously rotating frame or stationary frame. From this 2-phase component, the reference vector magnitude can be found and used for modulating the inverter output. The process for obtaining the rotating space vector is explained in the following section, considering the stationary reference frame.

SVPWM refers to a special switching sequence of the upper three power transistors of a three-phase power inverter. It has been shown to generate less harmonic distortion in the output voltages and currents applied to the phases of an AC motor and to provide more efficient use of supply voltage. There are two possible vectors called zero vector and Active vector. The objective of space vector PWM technique is to approximate the reference voltage vector V_{ref} using the eight switching patterns.

INVERTER BASIC & SWITCHING STATES

The circuit model of a typical three-phase voltage source bridge inverter is shown in Figure, S1 to S6 are the six power switches that shape the output, which are controlled by the switches s1,s4 for phase A, s3,s2 for phase B and s5,s6 for phase C. When an upper switches is switched on, i.e., when s1,s3 and s5 is 1, the corresponding lower switches is switched off, i.e., the Corresponding s2,s4 and s6 is 0. The available eight different switching states of the three phase inverter are depicted in the Fig (b). Note that all the machine terminals are connected to each other electrically and no effective voltages are applied to machine when the zero vectors presented by states (000) and (111).

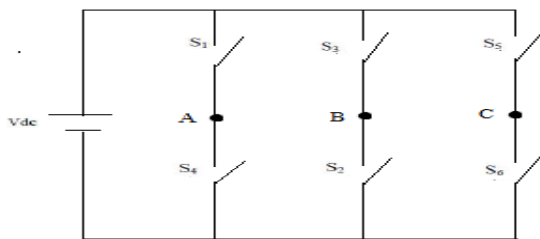

Figure 1: Three phase Inverter

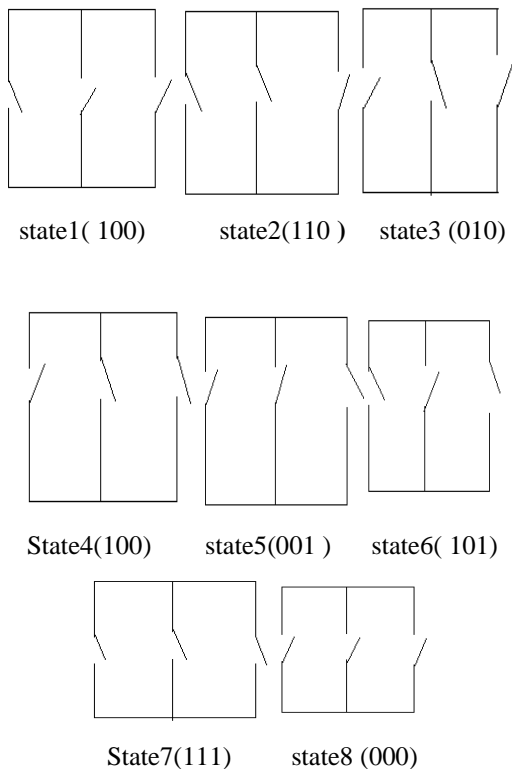

Figure 2: Switching positions of inverter in states S₁-S₈

For one PWM operation it requires one out of eight states such that the average output voltage is sinusoidal. States 1,2,3,4,5,and 6 produce non zero output voltage ,these states lies on the space vector..The pole voltages in state 100 phase A is at Vdc in 110 phases A,B are at Vdc,in 010 state phase B is Vdc,in 011 state phases B,C are at Vdc ,in state 001 phase

C is at Vdc,in state 101 phases A and C are at Vdc.By combining all the pole voltages it is hexagon whose radius is equal to the space vector as shown in below figure.In fig(c) all the six active voltage vectors lie along the radii of hexagon. The maximum radius of space vector is $\frac{\sqrt{3}}{2} V_{dc}$.Here the reference space vector Vref is rotating at uniform speed.

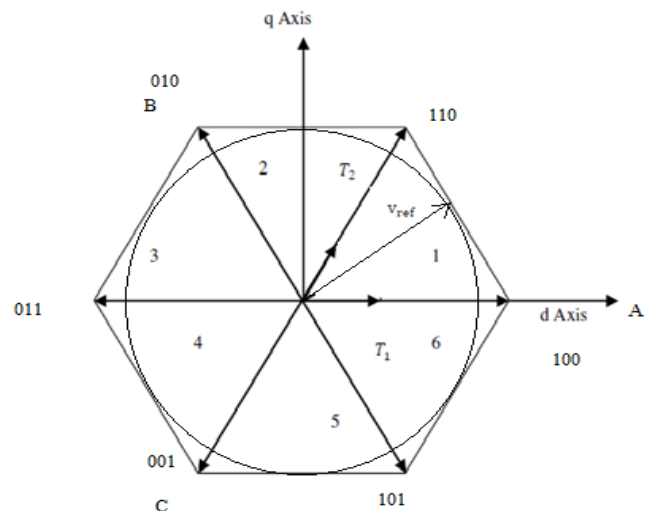

Figure 3: Space Vector

To determine how the space vector works in one sector 1 following diagram is considered

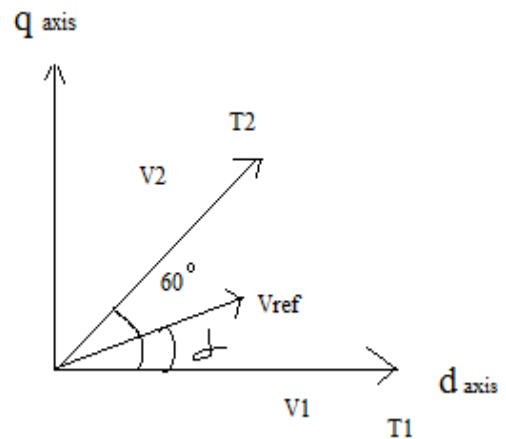

Figure 4: V_{ref} in sector S₁

T₁, T₂, T₀ are calculated as follows along α axis

$$V_1 T_1 + (V_2 \cos 60^\circ) T_2 = |V_s| T_s \cos \alpha \text{-----(1)}$$

T₁, T₂, T₀ are calculated as follows along β axis

$$0 + (V_2 \sin 60^\circ) T_2 = V_s T_s \sin \alpha \text{-----(2)}$$

$$T_1 = T_s \cdot (|V_s|/V_{dc}) \cdot (\sin(60-\alpha)/\sin 60^\circ) \quad |V_1|=|V_2|=V_{dc}$$

$$T_1 = T_s \cdot (|V_s|/V_{dc}) \cdot (\sin(60-\alpha)/(\sqrt{3}/2)) = T_1 = T_s (V_s/V_{dc}) \sin (60-\alpha)/(2/\sqrt{3})\text{-----(3)}$$

Similarly

$$T_2 = T_s \cdot (|V_s|/V_{dc}) (2/\sqrt{3}) \sin \alpha \text{-----(4)}$$

In a sector α varies $0 \leq \alpha \leq 60^\circ$

So we have to compute T_1, T_2 for α varies 60°

$$T_0 = T_s - (T_1 + T_2)$$

Inverse switching also associated switching losses to achieve minimum switching T_1, T_2, T_0 called subintervals. Minimum switching means T_0 interval is divided into two intervals. That is $T_{01}, T_{02}, T_{01} = T_{02} = T_0/2$ as shown in fig(5) and fig(6). That will ensure minimum inverter switching interval. The switching sequence in sector 1 is shown in fig(7). The switching transition, the switching subintervals are selected in such a way that only once the inverter leg is switched.

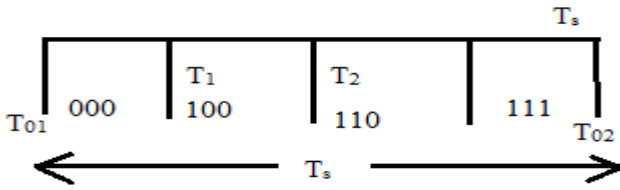

Figure 5: Minimum switching interval

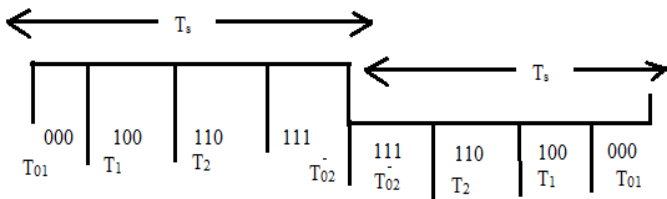

Figure 6: Minimum switching sampling interval

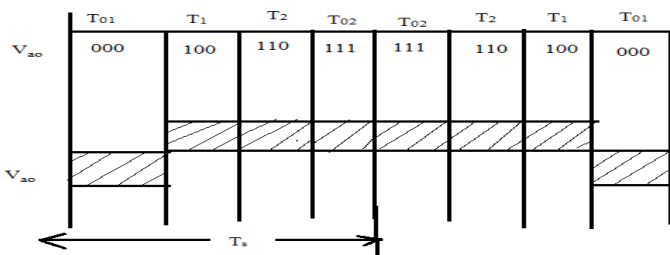

Figure 7: switching interval in sector 1

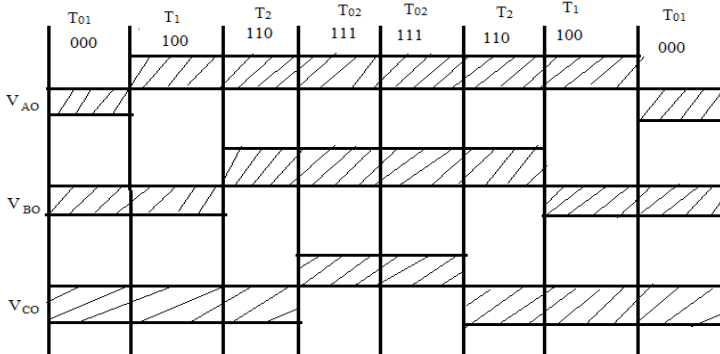

Figure 8: The average output voltage V_{AO}, V_{BO} and V_{CO}

$$V_{AO} \text{ (average)} = (V_{dc}/2)/T_s [-T_0/2 + T_1 + T_2 + T_0/2]$$

$$V_{BO} \text{ (average)} = (V_{dc}/2)/T_s [-T_0/2 - T_1 + T_2 + T_0/2]$$

$$V_{CO} \text{ (average)} = (V_{dc}/2)/T_s [-T_0/2 - T_1 - T_2 + T_0/2]$$

During $T_0/2$ period, the pole voltages are in opposite level. That means the zero vectors are not contributing the average variation.

$$V_{AO} \text{ (avg)} = (V_{dc}/2)/T_s [T_1 + T_2]$$

$$V_{BO} \text{ (avg)} = (V_{dc}/2)/T_s [-T_1 + T_2]$$

$$V_{CO} \text{ (avg)} = (V_{dc}/2)/T_s [-T_1 - T_2]$$

$$V_{CO} = -V_{AO}$$

By substituting T_1, T_2 in V_{ao}, V_{bo} and V_{co}

$$\begin{aligned} V_{ao} \text{ (avg)} &= (V_{dc}/2)/T_s [T_1 + T_2] \\ &= (V_{dc}/2)/T_s [(2/\sqrt{3}) T_s (V_s/V_{dc}) \sin(60-\alpha) + \\ &T_s (V_s/V_{dc}) (2/\sqrt{3}) \sin \alpha] \\ &= V_s/\sqrt{3} [\sin 60 \cos \alpha - \cos 60 \sin \alpha + \sin \alpha] \\ &= V_s/\sqrt{3} [(\sqrt{3}/2) \cos \alpha - (1/2) \sin \alpha + \sin \alpha] \\ &= V_s/\sqrt{3} [(\sqrt{3}/2) \cos \alpha + (1/2) \sin \alpha] \end{aligned}$$

Average variations tracing sinusoidal PWM. That means appropriately choosing T_1, T_2 for a particular frequency. We can draw SVPWM as shown in fig (9).

Average variation of space vector tracing a circle. For sector 1, $T_0 = T_{01}/2, T_{02}/2$

Sector 1

$$V_{ao} \text{ (avg)} = (V_{dc}/2)/T_s [T_1 + T_2]$$

$$V_{bo} \text{ (avg)} = (V_{dc}/2)/T_s [-T_1 + T_2]$$

$$V_{co} \text{ (avg)} = (V_{dc}/2)/T_s [-T_1 - T_2] = -V_{ao}$$

$$T_1 = T_s (|V_s|/V_{dc}) (2/\sqrt{3}) \sin(60-\alpha)$$

$$T_2 = (V_s/V_{dc}) (2/\sqrt{3}) \sin \alpha$$

$$V_{ao} \text{ (avg)} = (V_{dc}/2) T_s [T_s |V_s|/V_{dc} 2/\sqrt{3} \sin(60-\alpha) + T_s/V_{dc} \cdot V_s (2/\sqrt{3} \sin \alpha)]$$

$$V_{ao} \text{ (avg)} = (V_s/\sqrt{3}) \sin(60+\alpha) \text{ average value in sector 1.}$$

$$V_{bo} \text{ (avg)} = (V_{dc}/2) T_s [T_s |V_s|/V_{dc} 2/\sqrt{3} \sin(60-\alpha) + T_s |V_s|/V_{dc} (2/\sqrt{3} \sin \alpha)]$$

$$V_{bo} \text{ (avg)} = |V_s| \sin(\alpha-30)$$

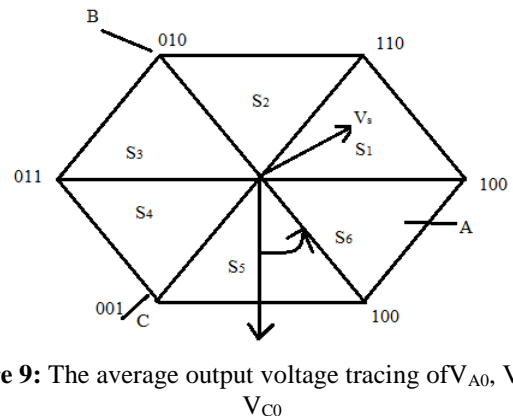

Figure 9: The average output voltage tracing of V_{AO}, V_{BO} and V_{CO}

$$V_{ao} \text{ (avg) in } S_1 = (|V_s|/\sqrt{3}) \sin(60+\alpha)$$

$$V_{bo} \text{ (avg) in } S_1 = (|V_s|/\sqrt{3}) \sin(\alpha-30)$$

$$V_{ao} \text{ (avg) in } S_1 = -V_{ao} \text{ (avg)}$$

$$V_{ao} \text{ (avg)} = |V_s|/\sqrt{3} \sin(\alpha+60) \text{ substituting } \alpha=\omega t-30^\circ, \omega t=60+\alpha$$

$$V_{ao} \text{ (avg)} = |V_s|/\sqrt{3} \sin(\omega t-30^\circ+60^\circ) = |V_s|/\sqrt{3} \sin(\omega t+30^\circ), 0 \leq \omega t \leq 30^\circ$$

$$V_{ao} \text{ (avg)} = |V_s| \sin(\omega t+30^\circ), 30^\circ \leq \omega t \leq 90^\circ$$

$$V_{ao} \text{ (avg)} = |V_s|/\sqrt{3} \sin(\omega t+30^\circ)$$

$V_{ao} \text{ (avg)} - V_3 = \text{sinusoidal waveform}$

For the S vector for sine triangle we get a boost in the voltage. The boost in the voltage is

$V_{A(max)} = V_{DC} / \sqrt{3} = 0.577 V_{DC}$, this is the extra boost in sinusoidal PWM. This extra boost will make the slightly increased modulation. All sectors in SVPWM are shown in Figure (11). It uses a set of vectors that are defined as instantaneous space vectors of the voltages and currents at the input and output of the inverter. These vectors are created by various switching states that the inverter is capable of generating.

PROPOSED SYSTEM

The objective of space vector PWM technique is to approximate the reference voltage vector V_{ref} using the eight switching patterns. Block diagram of the DTC using svpwm is shown in below figure (10).

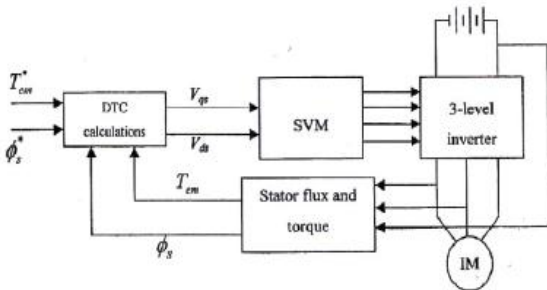

Figure 10: DTC using SVM block diagram.

One simple method of approximation is to generate the average output of the inverter in a small period, T to be the same as that of V_{ref} in the same period. Therefore, space vector PWM can be implemented by the following steps:

MODELLING OF SVPWM:

- Step 1 : Determine V_d, V_q, V_{ref} , and angle (Θ)
- Step 2 : Determine time duration T_1, T_2, T_0
- Step 3 : Determine the switching time of each transistor (S_1 to S_6)

To implement the space vector PWM, the voltage equations in the abc reference frame

can be transformed into the stationary dq reference frame as follows

$$V_{dq} = \frac{2}{3} \begin{bmatrix} 1 & -1/2 & -1/2 \\ 0 & \sqrt{3}/2 & -\sqrt{3}/2 \\ 1/2 & 1/2 & 1/2 \end{bmatrix} V_{abc}$$

The relationship between the switching variable vector $[a, b, c]^T$ and the line-to-line voltage vector $[V_{ab} \ V_{bc} \ V_{ca}]^T$ is given in the following

$$\begin{bmatrix} V_{ab} \\ V_{bc} \\ V_{ca} \end{bmatrix} = V_{dc} \begin{bmatrix} 1 & -1 & 0 \\ 0 & 1 & -1 \\ -1 & 0 & 1 \end{bmatrix} \begin{bmatrix} a \\ b \\ c \end{bmatrix}$$

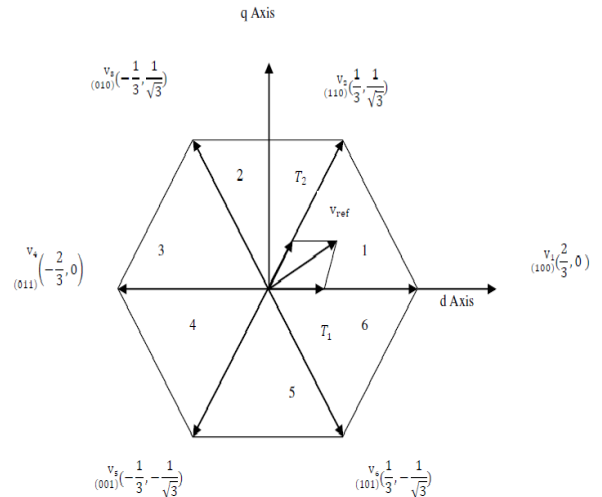

Figure 11: Space Vector Diagram with Sectors

DESIGN OF SIMULINK DIAGRAM:

Below figure (12) shows the simulink diagram of direct torque controlled induction motor drive with space vector modulation.

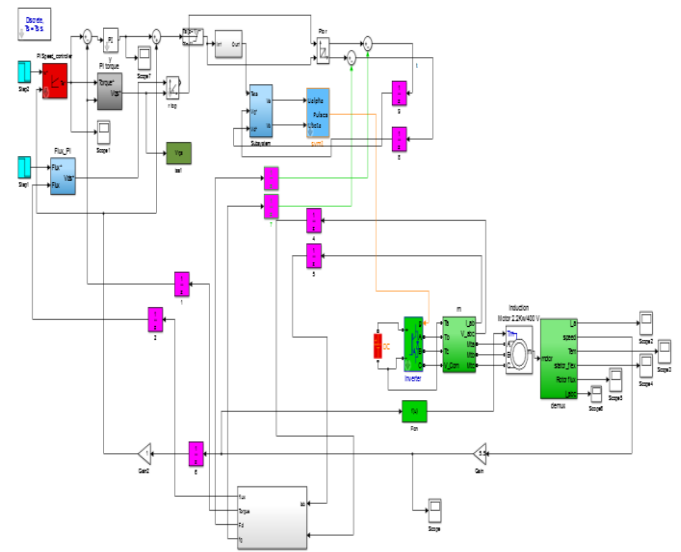

Figure 12: Simulink diagram of SVM based DTC induction motor

RESULTS AND CONCLUSION:

Following figures shows the comparison of results obtained by simulating DTC with PI controller, DTC with PWM and DTC with SVPWM. Time analysis (rise time, delay time, peak time and over shoot) has been done and results are tabled in table 1, 2 and 3. Figure (13),(14) shows the torque waveform of pwm and svpwm respectively. Figure (15) shows the improvement in the torque waveform of svpwm. Figure(17) shows the speed comparison of pwm and svpwm. Figure(18) and (19) shows the phase voltages Va and Vb respectively.

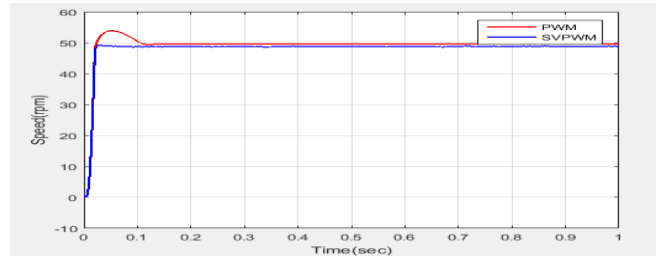

Figure 17: Comparison of speed (svpwm & pwm)

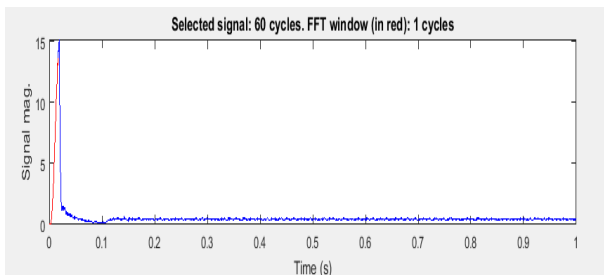

Figure 13: torque waveform of pwm

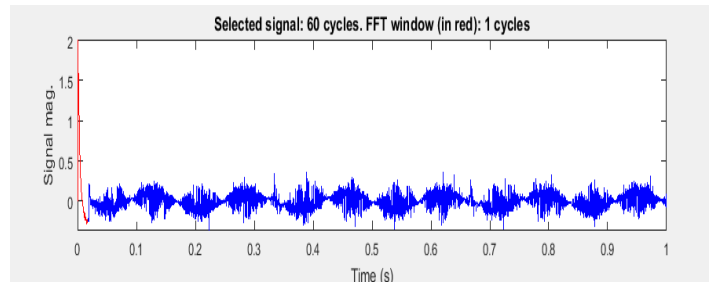

Figure 18: Va of svpwm

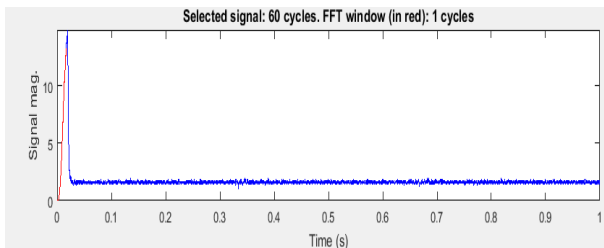

Figure 14: torque waveform of svpwm

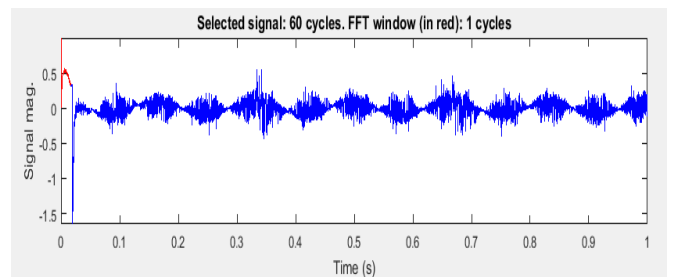

Figure 19: Vb of svpwm

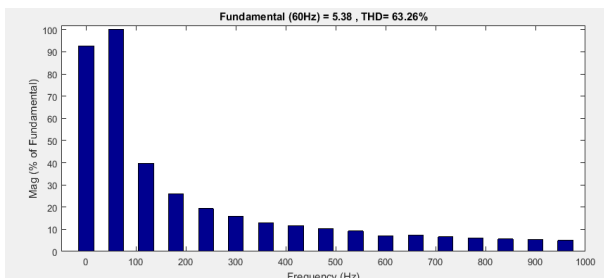

Figure 15: FFT of Torque (svpwm)

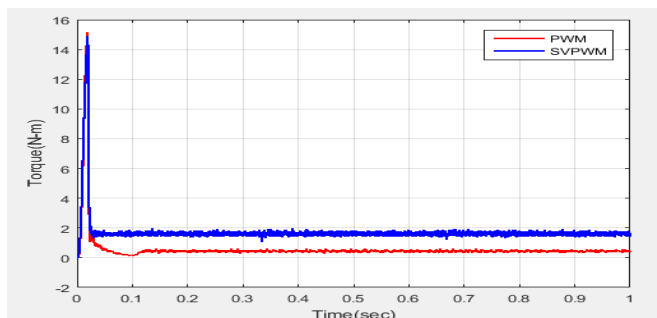

Figure 16: Comparison of torque (svpwm & pwm)

Table 1: Comparison table of peak time, rise time, slew rate, settling time and overshoot of DTC and PWM controlled I.M drive at 3000 rpm

	Speed (rpm)	t_p (sec)	t_r (sec)	Slewrate (v/sec)	t_s (sec)	Over shoot
DTC-PI	3000	0.03	0.0103	758.033	0.005711	0.505%
PWM	3000	0.054	0.010100	714.037	0.012	8.103%

In the table 1, shows peak time, rise time, slew rate, settling time and overshoot of DTC and PWM controlled I.M drive has been compared at the motor speed of 3000rpm.

Table 2: Comparison table of peak time, rise time, slew rate, settling time and overshoot of DTC and PWM controlled I.M drive at 1500 rpm

	Speed (rpm)	t _p (sec)	t _r (sec)	Slew rate (v/sec)	t _s (sec)	Over shoot
DTC-PI	1500	0.019	0.007655	1.033	0.012843	6.989%
PWM	1500	0.032	0.007398	970.837	0.0146	15.698%

In the table 2, shows peak time, rise time, slew rate, settling time and overshoot of DTC and PWM controlled I.M drive has been compared at the motor speed of 1500rpm.

Table 3: Comparison table of peak time, rise time, slew rate, settling time and overshoot of DTC and PWM controlled I.M drive at 1000 rpm

	Speed (rpm)	t _p (sec)	t _r (sec)	Slew rate (v/sec)	t _s (sec)	Over shoot
DTC	1500	0.019	0.007655	1.033	0.012843	6.989%
PWM	1500	0.032	0.007398	970.837	0.0146	15.698%

In the table 3, shows peak time, rise time, slew rate, settling time and overshoot of DTC and PWM controlled I.M drive has been compared at the motor speed of 1000rpm.

Table 4: Comparison table of peak time, rise time, slew rate, settling time and overshoot of SV PWM controlled I.M drive at 1000 rpm,1500rpm and 3000rpm

	Speed (rpm)	t _p (sec)	t _r (sec)	Slew rate (v/sec)	T _s (sec)	Over shoot
SVPWM	3000	0.028	0.010521	685.144	0.005986	0.505
SVPWM	1500	0.019	0.007	921.036	0.011061	5.851
SVPWM	1000	0.679	0.006643	1.044	0.014951	11.011

REFERENCES

- [1] Nalin Kant Mohanty, Ranganath Muthu and M.Senthil Kumaran, "A survey on controlled AC electrical drives", International Journal of Electrical and Power Engineering, 3(3), 2009,pp.175-183.G.Y. Goldstein. "Strategic Innovation Management: Trends, Technology, Practice: A Monograph". Taganrog: Publishing House TRTU, 2002.
- [2] R.Krishnan, "Electric Motor Drives –Modeling, Analysis, and Control",Prentice Hall ofIndia, 2002.
- [3] B.K.Bose, "Modern Power Electronics and AC Drives", Prentice – Hall, New Jersey,2002.
- [4] G. Habelter, F. Profumo, M. Pastorelli and L. Tolbert, Direct Torque Control of Induction Machines Using Space Vector Modulation, IEEE Trans. on Industry Applications, Vol. 28, No. 5, Sep./Oct. (1992), 1045.
- [5] C. Lascu, I. Boldea and F. Blaaajerg, A Modified Direct Torque Control For Induction Motor Sensorless Drive,IEEE Trans. on Industry Applications, Vol. 36, No. 1, Jan./Feb. (2000), 122.