

Lean Manufacturing and its Implementation

Suraj Kumar

Department of Mechanical Engineering, Bhagwant University, Ajmer.

Abstract

In its most basic form, lean manufacturing is the systematic elimination of waste from all aspects of an organization's operations, where waste is viewed as any use or loss of resources that does not lead directly to creating the product or service a customer wants when they want it. In many industrial processes, such non-value added activity can comprise more than 90 percent of a factory's total activity. Nationwide, numerous companies of varying size across multiple industry sectors, primarily in the manufacturing and service sectors are implementing such lean production systems, and experts report that the rate of lean adoption is accelerating. Companies primarily choose to engage in lean manufacturing for three reasons: to reduce production resource requirements and costs; to increase customer responsiveness; and to improve product quality, all which combine to boost company profits and competitiveness.

1. Introduction

A way to eliminate waste and improve efficiency in a manufacturing environment or a systematic approach to identifying and eliminating waste through continuous improvement, flowing the product at the pull of the customer in pursuit of perfection. It is also known as lean production. Another way of looking at Lean Manufacturing is that it aims to achieve the same output with fewer inputs – less time, less space, less human effort, less machinery, fewer materials, and fewer costs, and implementation represents its importance in industry.

1.1 Objectives of Lean Manufacturing

1. **Reducing defects** and unnecessary physical wastage, including excess use of raw material inputs.

2. **Reduce production cycle time** by reducing waiting times between processing stages.
3. **Minimize inventory levels** at all stages of production, particularly works-in-progress between production stages.
4. **Improve labor productivity** by reducing the idle time of workers.
5. **Effective utilization of equipment and space** by eliminating bottlenecks and minimizing machine downtime.
6. **Flexibility in production** with minimum changeover costs and changeover time.
7. **Increasing output** by achieving the above mentioned objectives.

2. Literature Review

2.1 Lean focuses on flow, the value stream and eliminating waste. This application is based on:

1. **Value:** The foundation for the value stream that defines what exactly customer is willing.
 - **Value Stream:** The mapping and identifying of all the specific actions required to eliminate the non-value activities from design concept to customer usage.
 - **Flow:** The elimination of all process stoppages to make the value stream “flow” without interruptions.
 - **Pull:** The ability to streamline products and processes from concept through customer usage.
 - **Perfection:** The ability to advocate doing things right the first time through the application of continuous improvement efforts.

2.2 Four Thrusts of Lean Manufacturing

1. Solid leadership that:

- Communicates the vision
- Facilitates and models the behaviors of lean manufacturing.
- Sets the standards for the organization
- Assists the workforce in adapting to the change

2. Team-based cultures that

- Use project-oriented, team-based structures that focus on empowerment concepts
- Leverage knowledge by using highly skilled workers
- Promote employee accountability and responsibility for work
- Builds trust and inspires commitment

3. Communication systems

- Promote knowledge sharing between hourly workers, management, and design personnel.

- Drive the behaviors of internal operations, as well as focus on the behaviors of suppliers and customers.
- Accept formal and informal communicate.

4. Simultaneous development and continuous improvement processes on

- Design the product right the first time.
- Use continuous improvement processes to identify the non-value-added problems.
- Drive commitment to eliminating problems
- Continuously train and develop highly skilled workers.
- Use scoreboards or measurement systems to monitor progress
- Uses Lean Manufacturing

2.3 Key Lean Manufacturing Techniques

1. Kaizen Rapid Improvement Process
 2. 5S
 3. Total Productive Maintenance (TPM)
 4. Cellular Manufacturing / One-piece Flow Production Systems
 5. Production / Kanab
 6. Six- Sigma
 7. Pre-Production Planning
 8. Lean Enterprise Supplier Networks
- ***Kaizen Rapid Improvement Process:*** Lean production is founded on the idea of kaizen, or continual improvement. This philosophy implies that small, incremental changes routinely applied and sustained over a long period result in significant improvements. The kaizen strategy aims to involve workers from multiple functions and levels in the organization in working together to address a problem or improve a particular process. The team uses analytical techniques, such as Value Stream Mapping, to quickly identify opportunities to eliminate waste in a targeted process.
 - **5S:** 5S is a system to reduce waste and optimize productivity through maintaining an orderly workplace and using visual cues to achieve more consistent operational results. It derives from the belief that, in the daily work of a company, routines that maintain organization and orderliness are essential to a smooth and efficient flow of activities. Implementation of this method “cleans up” and organizes the workplace basically in its existing configuration, and it is typically the starting point for shop-floor transformation. The 5S pillars, Sort , Set in Order , Shine, Standardize , and Sustain , provide a methodology for organizing, cleaning, developing, and sustaining a productive work environment. 5S encourages workers to improve the physical setting of their work and teaches them to reduce waste, unplanned downtime, and in-process inventory. A typical 5S implementation would result in significant reductions in the square footage of space needed for existing operations. It also

would result in the organization of tools and materials into labeled and color coded storage locations, as well as “kits” that contain just what is needed to perform a task.

- **Total Productive Maintenance (TPM):** Total Productive Maintenance (TPM) seeks to engage all levels and functions in an organization to maximize the overall effectiveness of production equipment. This method further tunes up existing processes and equipment by reducing mistakes and accidents. Whereas maintenance departments are the traditional center of preventive maintenance programs, TPM seeks to involve workers in all departments and levels, from the plant-floor to senior executives, to ensure effective equipment operation. TPM’s goal is the total elimination of all losses, including breakdowns, equipment setup and adjustment losses, idling and minor stoppages, reduced speed, defects and rework, spills and process upset conditions, and startup and yield losses.

Cellular Manufacturing/One-Piece Flow Systems: In cellular manufacturing, production work stations and equipment are arranged in a product-aligned sequence that supports a smooth flow of materials and components through the production process with minimal transport or delay. Implementation of this lean method often represents the first major shift in production activity and shop floor configuration, and it is the key enabler of increased production velocity and flexibility, as well as the reduction of capital requirements, in the form of excess inventories, facilities, and large production equipment. Fig. A illustrates the production flow in a conventional batch and queue system, where the process begins with a large batch of units from the parts supplier. The parts make their way through the various functional departments in large “lots,” until the assembled products eventually are shipped to the customer.

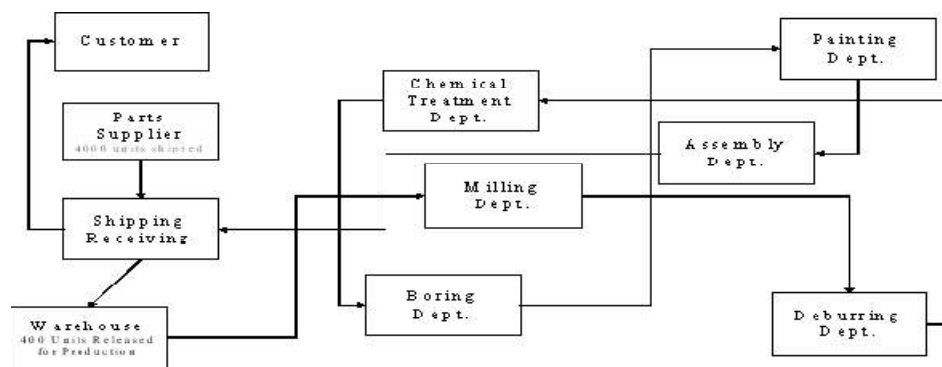

Fig. 1: Functionally-Aligned, Batch and Queue, Mass Production.

Rather than processing multiple parts before sending them on to the next machine or process step (as is the case in batch-and-queue, or large-lot production), cellular manufacturing aims to move products through the manufacturing process one-piece at a time, at a rate determined by customer demand (the *pull*). Cellular manufacturing can also provide companies with the flexibility to make quick “changeovers” to vary

product type or features on the production line in response to specific customer demands. This can eliminate the need for uncertain forecasting as well as the waste associated with unsuccessful forecasting. Fig. B illustrates production in this product-aligned, one-piece flow, pull production approach.

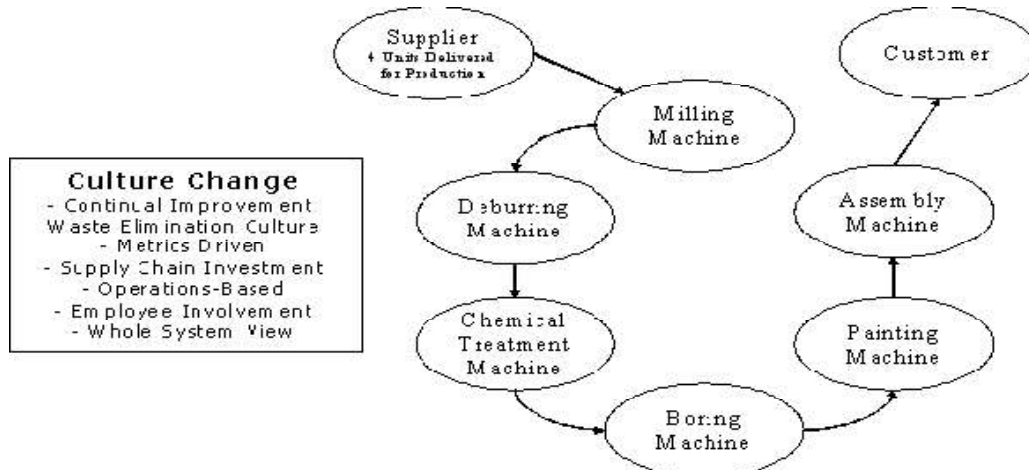

Fig. 2: Product-Aligned, One-Piece Flow, Pull Production.

- **Just-in-time Production Systems/Kanban:** Just-in-time production, or JIT, and cellular manufacturing are closely related. JIT enables a company to produce the products its customers want, when they want them, in the amount they want. JIT techniques work to level production, spreading production evenly over time to foster a smooth flow between processes. JIT frequently relies on the use of physical inventory control cues (or *kanban*), often in the form of reusable containers, to signal the need to move or produce new raw materials or components from the previous process. Many companies implementing lean production systems are also requiring suppliers to deliver components using JIT. The company signals its suppliers, using computers or delivery of empty containers, to supply more of a particular component when they are needed. The end result is typically a significant reduction in waste associated with unnecessary inventory, WIP, packaging, and overproduction.
- **Six-Sigma:** Six-Sigma was developed by Motorola in the 1990s where a sigma quality level equates to approximately 3.4 defects per million opportunities, representing high quality and minimal process variability. Six-Sigma consists of a set of structured, data-driven methods for systemically analyzing processes to reduce process variation, which are sometimes used to support and guide organizational continual improvement activities. Six Sigma's toolbox of statistical process control and analytical techniques are being used by some companies to assess process quality and waste areas to which other lean methods can be applied as solutions. Six-Sigma is also being used to further drive productivity and quality improvements in lean operations.

- ***Pre-Production Planning (3P):*** A Pre-Production Planning (3P) focuses on eliminating waste through “Greenfield” product and process redesign. Lean experts typically view 3P as one of the most powerful and transformative advanced manufacturing tools, and it is typically only used by organizations that have experience implementing other lean methods. 3P seeks to meet customer requirements by starting with a clean product development slate to rapidly create and test potential product and process designs that require the least time, material, and capital resources. This method typically engages a diverse group of employees (and at times product customers) in a week-long creative process to identify several alternative ways to meet the customer’s needs using different product or process designs. Participants seek to identify the key activities required to produce a product (e.g., shaving wood for veneer, attaching an airplane engine to the wing), and then look for examples of how these activities are performed in nature. Promising designs are quickly “mocked up” to test their feasibility, and are evaluated on their ability to satisfy criteria along several dimensions (e.g., capital cost, production cost, quality, time). 3P can also design production processes that eliminate multiple process steps and that utilize homemade, right-sized equipment that better meet production needs.
- ***Lean Enterprise Supplier Networks:*** To fully realize the benefits of implementing advanced manufacturing systems, many companies are working more aggressively with other companies in their supply chain to encourage and facilitate broader adoption of lean methods. Lean enterprise supplier networks aim to deliver products of the right design and quantity at the right place and time, resulting in shared cost, quality, and waste reduction benefits. As companies move to JIT production, the implications of supply disruptions due to poor quality, poor planning, or unplanned downtime become more acute. Some suppliers may increase their own inventories to meet their customer’s just-in-time needs, merely shifting inventory carrying costs upstream in the supply chain. At the same time, some lean companies are finding value in tapping supplier knowledge and experience by collaborating with key suppliers to design components, instead of sending out specifications and procuring from the low bidder. It is estimated that many companies can only lean operations by 25 to 30 percent if suppliers and customer firms are not similarly leaned. Specific techniques can include training, technical assistance, annual supply chain meetings, site visits, employee exchanges, and joint projects (e.g., product or component design).

3. Findings

Lean manufacturing processes are being used predominantly in the automotive industry. Toyota Motor Company, considered the leader in lean manufacturing techniques, started using the techniques:

Toyota Motor Company Toyota Production System
Ford Motor Company Ford Production System
Chrysler Chrysler Operating System
Porsche The Porsche Improvement Process
General Motors NUMMI New United Motor Manufacturing Inc.

3. 1 Lean Manufacturing is sometimes called the Toyota Production System (TPS) because Toyota Motor Company's are given credit for its approach and innovations

1. Toyota Production System: The Toyota production system has been created on the practice and evolution of one very useful technique that reduces cost and time while challenges every activity in the value stream .It is applying a methodology known as the "Five whys." By asking why an activity is performed and then asking why after each response, it is frequently possible to get to the origin of the problem. Understanding the root cause assists in successful redesign. Value-Added versus Non-Value-Added Activities is the objective of any manufacturing company.

2. Four rules which characterize the "Toyota DNA"

1. All work shall be highly specified as to content, sequence, timing, and outcome.
2. Every customer-supplier connection must be direct, and there must be an unambiguous yes or no way to send requests and receive responses.
3. The pathway for every product and service must be simple and direct.
4. Any improvement must be made in accordance with the scientific method under the guidance of a teacher.

3.2 Toyota develops TPS

Toyota's development of ideas that later became Lean may have started at the turn of the 20th century, in a textile factory .when a thread broke, this became the seed of automation .Toyota's journey with JIT may have started back in 1934 when it moved from textiles to produce its first car, founder of Toyota Motor Corporation, directed the engine casting work and discovered many problems in their manufacture. He decided he must stop the repairing of poor quality by intense study of each stage of the process. In 1936, when Toyota won its first truck contract with the Japanese government, his processes hit new problems and he developed the "good change" improvement .After visit they saw and recognized the scheduling of work should not be driven by sales or production targets but by actual sales. Given the financial situation during this period, over-production had to be avoided and thus the notion of Pull (build to order rather than target driven Push) came to underpin production scheduling. It was with Taiichi Ohno at Toyota that these themes came together. He built on the already existing internal schools of thought and spread their breadth and use into what has now become the Toyota (TPS). It is principally from the TPS, but now including many other sources, that Lean production is developing.

3. WASTE: “the ultimate lean target is the total elimination of waste.”

Type of Wastes:

1. **Waste of overproducing:** Producing components that are neither intended for stock nor planned for sale immediately.
2. **Waste of waiting:** Refers to the idle time between operations.
3. **Waste of transport:** Moving material more than necessary.
4. **Waste of processing:** Doing more to the product than necessary and the customer is willing to pay.
5. **Waste of inventory:** Excess of stock from raw materials to finished goods.
6. **Waste of motion:** Any motion that is not necessary to the completion of an operation.
7. **Waste of defects and spoilage:** Defective parts that are produced and need to be reworked.

4. Conclusion

Lean production is all about working more effectively with time (the time available to produce each product). The teamwork approach is recognition that the best way to achieve this is for all members of the workforce to be involved to achieve a quick response. Lean production has enabled Jaguar to cut out waste in the production of the Jaguar S-type at Castle Bromwich. Ford is now seeking to spread the message about lean production by incorporating a total of 400 of its Hale wood employees into working at Castle Bromwich. The successful implementation of lean production at Jaguar will form the benchmark for the systems introduction at Hale wood. ***Lean produces an operational and cultural environment that is highly conducive to waste minimization and pollution prevention.*** It significantly improves overall productivity, increase market share, improve speed-to-market with new products and also reduce manufacturing and engineering labor costs. It eliminates the non-value-added operations. After study about lean manufacturing and its implementation we analyze important factors to achieve our goals. Benefits through Lean time and money has seen dramatic cuts and allowed company to expand for more regional coverage. It reduces time taken to accomplish certain tasks and add more responsibilities. At last we can say that lean manufacturing and its implementation in important topic.

References

- [1] Daniel T. Jones and Daniel Roos “The Machine That Changed the World” (1988)
- [2] Radnor & Bucky "Analysis of Lean Implementation" (2010)
- [3] Daniel T. Jones “Lean Thinking” (2008)
- [4] F & M Bale “The Gold Mine” by the Lean Enterprise Institute (2005)
- [5] Petersen, J “Defining lean production: some conceptual and practical issues” (2009)
- [6] Pat Lancaster “Lean Thinking's Lancaster Technologies” (2008)
- [7] Ohno, Taiichi “Toyota Production System” (1988)