

# **Solar Powered Automatic Rain Protection for Field Crops Using Arduino UNO and Moisture Level Monitoring System**

**Dr. G. Satheesh**

*Assistant professor, Electrical & Electronics Engineering Department  
G. Narayanamma Institute of Technology and Science Hyderabad, India  
e-mail: satheeshtrrec@gmail.com*

**M. Keerthana, A. Charitha, N. Vaishnavi, M. VarshaSri**

*Electrical & Electronics Engineering Department  
G. Narayanamma Institute of Technology and Science Hyderabad, India*

## **Abstract**

Agriculture is an important sector in India. “On average, 70% of households and 10% of the urban population rely on agriculture for their livelihoods. However, heavy rains cause farmers to face major problems as their crops are washed away or destroyed. To circumvent this problem, project is developed to protect crops from heavy rains. Whenever there is rainfall the rain sensor gets activated. Then, the controller indicates the DC motor to run which opens the roof automatically to close the field using a sheet. In this project, the roof is open automatically when the sensor is ON. In general, electrical energy obtained from a transformer can be used, but for sustainability reasons we have chosen solar energy, which is abundant nearby, as the energy source. Power source to this project is supplied through solar power which is a renewable energy.

**Keywords:** DC Motor, Blynk App, Solar Energy, Rain Sensor

## **1. INTRODUCTION**

The aim of the project is to design an automotive rain operated roof using solar energy to protect the field crops from rain. This project uses soil moisture sensor and temperature sensor for automatic irrigation. It consists of IOT technology to send the data into the Blynk mobile application. So, user can check and control the irrigation motor through Blynk app.

We humans have no control over natural phenomena such as rain, humidity, and heat. Several measures have been taken against this environmental hazard, but these are done

manually. Current systems cannot protect crops from natural disasters such as floods and rainfall, or from excessive heat from the sun. As a result, plant growth is reduced and yields are reduced. This project proposes a system to prevent crop rot due to heavy rain. This is achieved by designing embedded systems with sensors. This is where the need for automation arises. Automation also greatly reduces the need for human sensory and mental demands. An automated system consisting of a combination of hardware and software frees individuals from routine tasks. This project aims to establish new intelligent systems that help protect plants from environmental influences such as rain. This project utilizes solar energy to run this project. Solar energy is stored in the battery via a charging circuit. This battery power is used to run the roof motor and the irrigation motor. The main control part of the project is the Arduino controller. A rain sensor, soil moisture sensor, temperature sensor, ESP8266 WI-FI module, irrigation motor, roof motor and motor driver are connected to the Arduino. When it rains on the sensor, the sensor detects this signal and sends it to the Arduino. The Arduino then covers the crop canopy with the help of his DC motor. The Arduino reads data from soil moisture and temperature sensors and updates it in the Blynk app. Based on; the user controls and controls the motor via the Blynk app. For this purpose, the task controller is programmed in the embedded C programming language.

## 2. BLOCK DIAGRAM

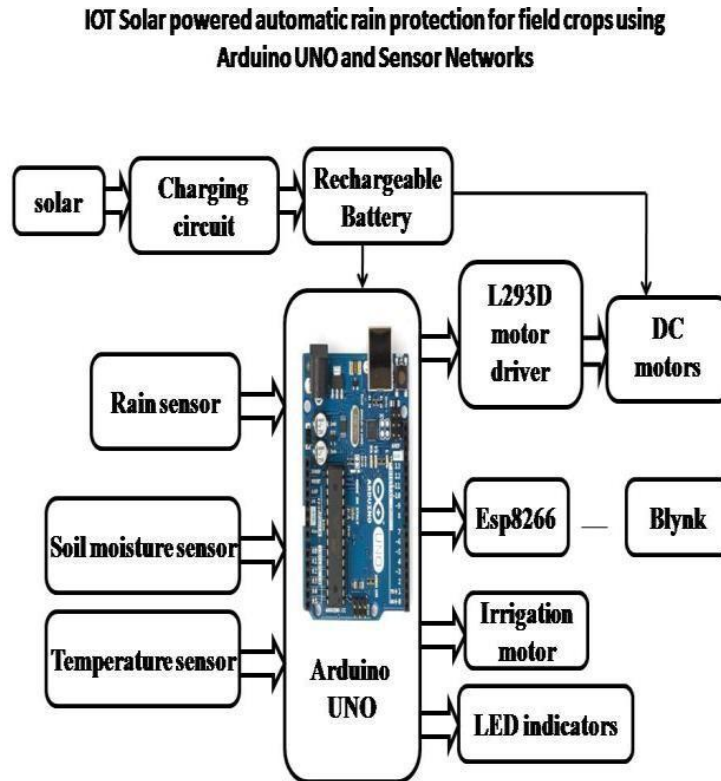

Figure 1. Block Diagram

### **3. WORKING**

Power is supplied to the entire circuit. Turn on the battery button to power the entire circuit. First, when rain(water) falls on the rain sensor, the rain threshold is sent to the Arduino. According to the code, if the threshold is greater than the pre-set value, the crop roof will be closed. This is done through the motor driver. The code is written as in temperature, humidity monitoring and plant watering, the temperature and humidity values are read through sensors and sent to the Blynk app using Arduino and ESP8266 module. These values are displayed in the Blynk app. You can turn the irrigation motor on or off according to your needs. Clicking one of the buttons will pass a signal to the Arduino.

### **4. SOFTWARE USED**

Embedded C: Embedded systems are computer systems designed to perform one or more specialized functions, often with limited real-time computation. It is part of a complete device, often including hardware and mechanical parts. Embedded systems are controlled by one or more main processing cores, typically either microcontrollers or digital signal processors (DSPs).

### **5. TESTING**

#### **5.1 TESTING 1**

Whenever raindrops fall on the rain sensor the roof automatically gets opened (considering cultivated crops are on the other side). When it is dried off roof automatically closes



**Figure 2.** Testing 1

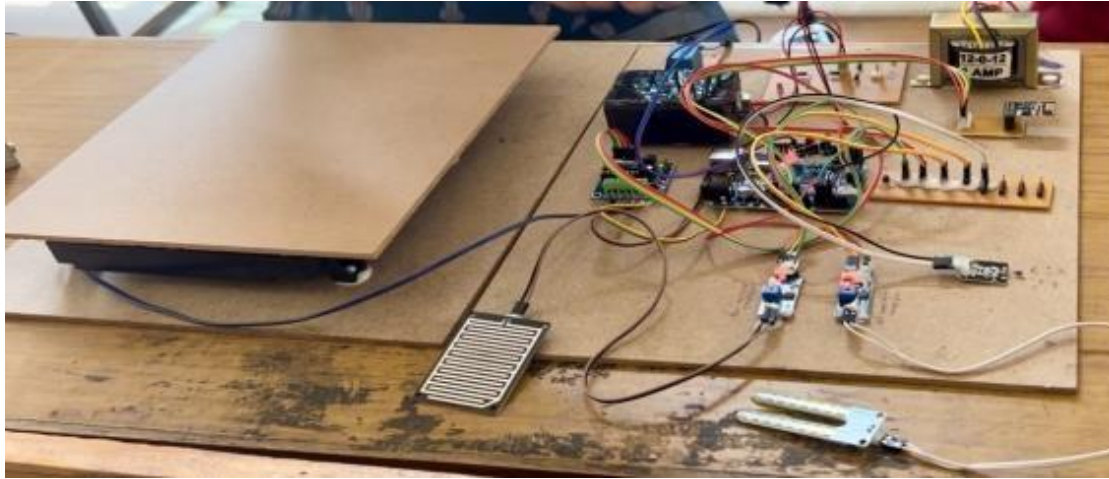

**Figure 3.** Testing 1

## 5.2 TESTING 2

Based on the moisture content in the soil we can either turn on or turn off the motor for irrigating crops through Blynk app as shown in the below figure.

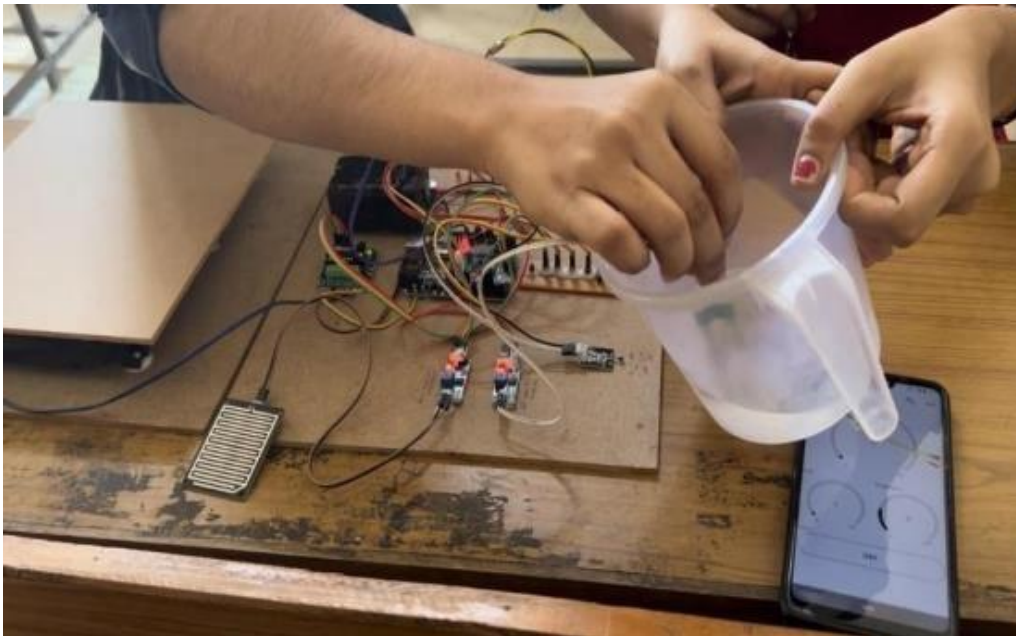

**Figure 4.** Testing 2

## 5.3 TESTING 3

If the temperature increases, we can turn on the motor using Blynk app as shown in fig 3.

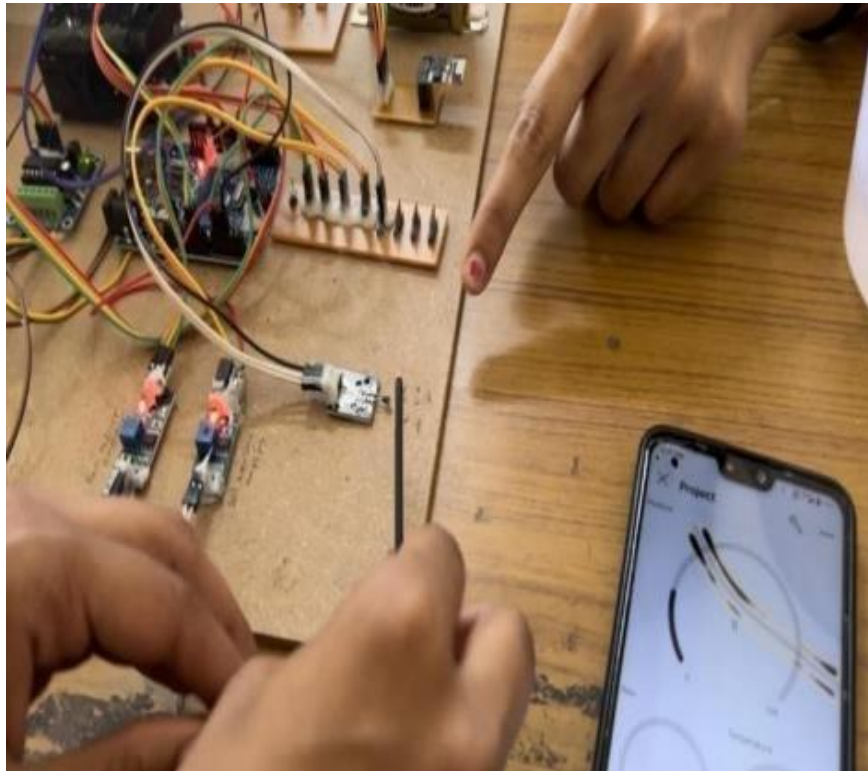

**Figure 5.** Testing 3

#### **4.4 TESTING 4**

Turning ON the motor using blynk app shown in below figure.



**Figure 6.** Testing 4

**BLYNK APP**

Blynk app is used to Remotely monitor and control connected devices running on the Blynk platform. Configuration of mobile user interfaces during prototyping and production stages. Automate operations on connected devices. The following image shows the interface of the Blynk app. Can be customized according to your needs Displays temperature, soil and humidity values. Arduino is connected to Blynk app via ESP8266 Wi-Fi module. The Blynk App model is shown in the below figure.

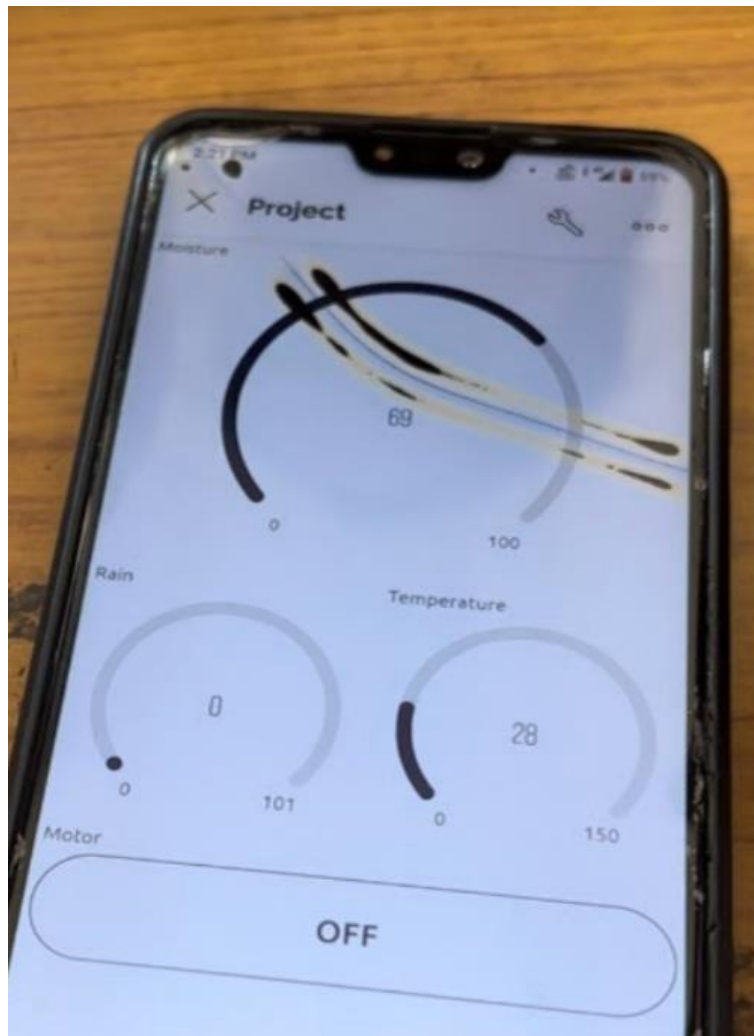

**Figure 7.** Blynk App

**5. CONCLUSION**

A solar powered automatic rain roofing system with blink IOT controlling is a sustainable and efficient solution to protect crops from excessive rainwater damage. This system is powered by solar energy making it an environmentally friendly solution that reduces the carbon print associated with traditional energy sources. The system is

designed to automatically deploy a protective covering over crops when it detects the presence of rain, ensuring that the crops remain safe and healthy. The system can be controlled remotely using the Blynk IoT platform. This feature allows farmers to monitor and control the system from anywhere in the world, giving them greater flexibility and control over their farming operations. The system is also highly customizable, allowing farmers to adjust the parameters to suit their specific needs. Additionally, the system is designed to be scalable, making it suitable for small-scale as well as large-scale farming operations.

Overall, the solar-powered automatic rain roofing system with Blynk IoT controlling is a highly promising technology that has the potential to revolutionize the way crops are protected from rainfall. With further development and optimization, this technology can become a highly valuable tool for farmers, improving crop yield and quality while reducing the environmental impact of traditional agricultural practices.

#### **ADVANTAGES:**

- 1) One of the significant benefits of the system is its sustainability. It relies on solar power, making it an environmentally friendly solution that reduces the carbon footprint associated with traditional energy sources.
- 2) Additionally, the system is designed to be self-sufficient, requiring little maintenance and reducing the operational costs associated with traditional agricultural practices.

#### **DISADVANTAGES**

- 1) **Initial cost:** The initial cost of setting up the system can be high, especially for small farmers who may not have the financial resources to invest in such a system. However, over time the system can pay for itself in terms of increased crop yield and reduced crop damage.
- 2) **Maintenance:** Like any other technological systems, the solar-powered automatic rain roofing systems requires regular maintenance to ensure that it operates efficiently. Farmers may need to invest time and resources to keep the system functioning properly.

#### **REFERENCES**

- [1] KadakiaNishant, A Kothari, Mohit A Shah, Amit V Patel Vipul R: “*Automatic Rain Operated Wiper System in Automobile*”, International Journal for Scientific Research & Development Mr.G.L.Borhade, Komal Pawar, Snehal Dongare, Pratiksha Bhor.”*Automatic Rain Water and Crop Saving System*”, IRJET, Volume: 08 Issue: 02 | Feb 2021
- [2] R. Balathandapani, D. Boopathi, S. Jotheeshwaran, G. Arundeva, C. Saranya: “*Automatic Rain Water And Crop Saving System Using Embedded Technology*”,

- International Journal of Science, Engineering and Technology Research (IJSETR) Volume 4, Issue 3, March 2015
- [3] Venkata Naga RohitGunturi, “*Micro Controller Based Automatic Plant Irrigation System*”, International Journal of Advancements in Research & Technology.
- [4] R.Hussain, J.Seegal, A.Gangwar, M.Riyag “ *Control of irrigation automatically byusing wireless sensor network*” International journal of soft computing and engineering, vol.3, issue 1, march 2013.
- [5] Ritik Bansod, Nachiket Kamble, Pratik Nimje, Kartik Muddamwar, Palkesh Kotrunge, Prof. Pravin Pisal “*Automatic crop protection from heavy rainfall and preserving water using IoT*”, Volume:04/Issue:04/April-2022