

Harnessing APFC for Optimal Efficiency: A deep Dive into Technical and Economic Benefits for Utility Substations

¹Sanika N. Zope* and ²Dr. Nitin S. Zope

¹Member, IEEE, Govt. College of Engineering, Aurangabad (M.S.), India

²Addl. Executive Engineer, MSETCL, Maharashtra, India

Abstract

This paper presents a case study on the design, simulation, and implementation of an Automatic Power Factor Correction (APFC) system at the 400kV Waluj substation, installed to address low power factor penalties and improve overall energy efficiency. The APFC system, controlled by a microcontroller, dynamically adjusts capacitor banks to maintain an optimal power factor and mitigate harmonics. A MATLAB simulation was developed to model the system's behavior, illustrating its effectiveness in reactive power compensation, though lacking the full automation present in the installed system. Usually implementing such strategy where low power factor penalty is more, could save significant amount leading to generation of revenue. The economic analysis indicates a favorable Return on Investment (ROI) and positive Net Present Value (NPV), making the APFC system a cost-effective solution for reducing tariff penalties and enhancing system performance.

Keywords: APFC, Microcontroller, MATLAB, NPV, ROI

I. Introduction

Maintaining a high-power factor (PF) is critical for the efficient operation of electrical systems, particularly in industrial and large commercial facilities. A low power factor not only leads to increased power losses but also incurs significant tariff penalties from utility providers. The Waluj substation, serving a major industrial area, was facing persistent low PF issues, resulting in hefty financial penalties. In response to this challenge, an Automatic Power Factor Correction panel was implemented to dynamically adjust the reactive power consumption and optimize the power factor. An APFC system automatically monitors and corrects the power factor by switching capacitor banks in or out of the circuit based on the reactive power demand. This automated correction significantly improves system efficiency by reducing reactive power flow, minimizing losses, and avoiding penalties imposed due to non-compliance with power factor regulations.

This paper presents a case study of the APFC system installed at the 400kV Waluj Substation, providing a detailed analysis of its design, implementation, and operational and financial benefits. The study is further supplemented with a simulation model developed in MATLAB Simulink to replicate the system's performance under varying load conditions. Although the simulation model lacks microcontroller-based automation, it offers valuable insights into the system's potential to improve power factor and reduce energy consumption.

II. Literature Review

Automatic power factor correction systems have been a significant focus of research due to their critical role in enhancing electrical system efficiency and reducing operational costs. Early research on APFC systems concentrated on the basic design and implementation of capacitor banks, which are switched in and out of the circuit based on real-time power factor measurements. These systems were primarily mechanical, relying on electromechanical relays, which, while effective, had limitations in response time and durability. Advancements in microelectronics and digital control technologies have led to significant improvements in APFC systems. Modern APFC units utilize microcontrollers and digital signal processors (DSPs) to provide more precise and rapid adjustments to the power factor.

Recent research has also explored the integration of APFC systems with smart grid technologies and the Internet of Things (IoT). This integration allows for more adaptive and predictive power factor correction. Studies have highlighted the benefits of such integrations, including enhanced energy management, reduced operational costs, and improved grid stability.

Below are some valuable insights from the reference research paper-

- 1.) This paper highlights the importance of compensating for power factor (pf) deficiencies in industrial power systems, which often face penalties due to low pf from inductive loads. The authors propose an automatic power factor correction unit aimed at improving power system efficiency by restoring pf to near unity. The apfc system employs capacitor banks to compensate for reactive power, reducing system losses, improving voltage profiles, and increasing load-carrying capacity. The paper discusses various capacitor configurations (e.g., delta or star connection) and types, including low voltage and high voltage capacitors, and their tolerance limits. The system reduces penalties for poor pf while also providing economic benefits by improving operational efficiency.
- 2.) This paper presents a system for automatic power factor measurement and correction using mydaq and labview software. The system calculates the phase angle between voltage and current signals to determine the power factor. If the power factor drops below a set threshold, the system automatically engages capacitor banks to correct it. The integration of mydaq provides a data acquisition system that interfaces with labview for real-time measurement of real power (p), reactive power (q), and apparent power (s). The system uses current and voltage sensors to gather real-time data, and the logic for activating capacitors is implemented through relay circuits.

- 3.) This paper focuses on improving the power factor using a system controlled by arduino uno. The system employs a combination of current transformers (ct), voltage transformers (pt), and zero detection circuits to measure the phase angle between voltage and current. The power factor is calculated, and the system automatically switches on capacitor banks using relays to compensate for lagging reactive power caused by inductive loads. The paper also details the hardware implementation, including the use of lm741 op-amps, bd135 npn transistors, and sn74hc86n xor gates for zero detection and control. Capacitor banks with ratings of 10, 20, 40, and 80 μ f are used to provide leading reactive power (kvar) to the system, thus improving the power factor and reducing losses.

III. Objective of the Study

The objective of this paper is to identify and implement a solution that will effectively improve the power factor at the 400kV Waluj Substation of Maharashtra State Electricity Transmission Company Ltd. (MSETCL) to reduce or eliminate financial penalties incurred due to low power factor. The substation is currently facing significant penalties, as outlined by Tariff Order No. 18862 of the Maharashtra State Electricity Distribution Co. Ltd. (MSEDCL). This order imposes a 2% penalty on the monthly bill for the first percentage drop below a power factor (PF) of 0.9 and an additional 1% for each subsequent percentage point decrease.

Data Point	Parameter	Details
1	Consumer No.	490011723036
2	Consumer Name	THE EXECUTIVE ENGINEER
3	Address	400 KV SUB.STN.L.SEC. MIDC, WALUJ, M.S.E.T.C.L LTD
4	Pin Code	431001
5	Contract Demand (KVA)	80 KVA
6	Connected load (KW)	64.0 KW
7	Sanctioned load (KW)	64.0 KW
8	Tariff	36 LT-V B II
9	40 % of Contract Demand (KVA)	32.0 KVA

Table 1. Electricity Bill data (TF-1)

The two station transformers that supply power to the auxiliary systems at the substation are the primary contributors to these penalties:

- **Station Transformer-1** (Energy meter consumer No. 490011723044) operates with an average power factor of 0.85, resulting in a monthly penalty of ₹8,823.97 for January 2024.
- **Station Transformer-2** (Energy meter consumer No. 490011723036) operates with an average power factor of 0.80, leading to a penalty of ₹16,283.18 for the same period.

Month	KWH	KVA (MD)
JUN-23	28713	40
JUL-23	25805	32
AUG-23	24953	30
SEP-23	24859	32
OCT-23	24739	30
NOV-23	35968	72
DEC-23	32936	42
JAN-24	33542	41
FEB-24	31808	53
MAR-24	37222	73
APR-24	39212	75
MAY-24	38304	46
Avg Energy Consumption in KWH	31505	
Average Load of the Plant (Assuming 24 hours a day and 365 days a year)	~ 45 KW	

Table 2: Average kW Calculations Based on Data (TR-1)

The Low power factor is mainly due to inductive loading, At present at 400 kV Waluj S/s the Aux. Supply is maximum used for cooling system of 400/220 kV ICT-1,2 & ICT-3 with separate 4 units, 400 kV Line reactors and 220/33 kV Transformer-1 & 2.

Total @ 80 Nos. Fans with 2kW each and 14 Nos. Pumps with 2 KW each = @ 150 kW maximum Load for day & night & also additional yard lighting, Air conditioner load is added to this which is almost inductive loading @ 150 kW.

KWH	35448
KVAH	43767
RKVAH (LAG)	25628
RKVAH (LEAD)	0
KVA(MD)	97
AVG PF	0.810
LOAD FACTOR	-
BILLED DEMAND (KVA)	63

Table 3. Current Bill for the Month June-2024 Consumption Details (TF-1)

A. Based on the it following key Objectives are fabricated:

- 1.) **Analyse the Existing System:** Evaluate the power consumption patterns, reactive power demand, and power quality at the 400kV Waluj Substation through detailed system analysis and mathematical calculations.
- 2.) **Mitigate Financial Penalties:** By improving the power factor to 0.95, the goal is to minimize or eliminate the penalties levied by MSEDCL, thus reducing operational costs.
- 3.) **Design and Implement an APFC System:** Propose an Automatic Power Factor Correction (APFC) system with the appropriate specifications to meet the

substation's reactive power compensation needs while addressing harmonic distortions.

- 4.) **Simulation and Performance Review:** Simulate the expected performance of the APFC system and review its actual performance once implemented, ensuring that the system achieves the desired power factor improvement and harmonic mitigation.

IV. System Development

This section focuses on the power quality analysis and mathematical calculations essential for determining the specifications of an Automatic Power Factor Correction (APFC) system at the 400kV Waluj Substation. The need for power factor correction arises from the substation's existing operational inefficiencies, including low power factor and high reactive power demand, both of which result in financial penalties and reduced system performance. Additionally, the presence of harmonic distortion further complicates the system's performance, necessitating a more detailed evaluation before implementing an APFC solution.

A. Power Quality Analysis

Before deciding on the specifications for the Automatic Power Factor Correction (APFC) system at the 400kV Waluj Substation, a comprehensive load and power quality assessment was conducted. The analysis with the equipment details as shown was carried out to evaluate the substation's current power factor, reactive power consumption, and harmonic levels to propose a well-suited APFC system.

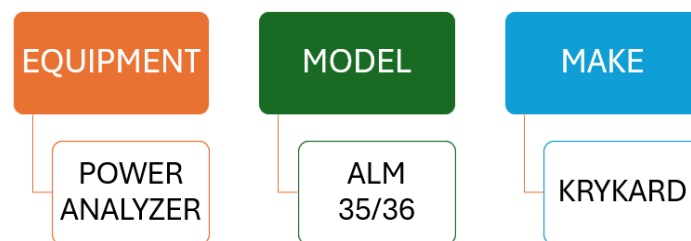

The substation's power consumption patterns were thoroughly studied over several months. Real-time measurements using a power analyser revealed that the average active load was approximately 54 kW, with a low power factor of 0.803, and a reactive power demand of 39 kVAR. The power factor fell well below the recommended level of 0.9, leading to penalties imposed by MSEDCL for poor power factor compliance.

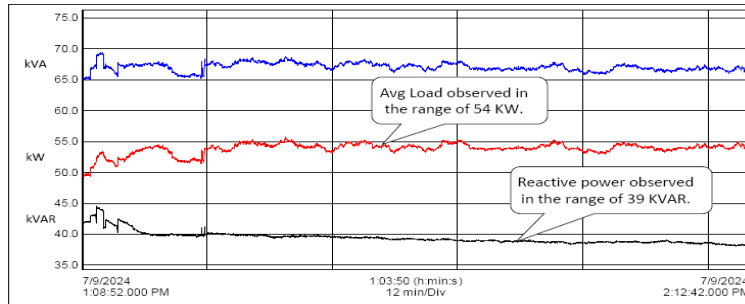

Figure 1: Power Curve (kW-Red, KVAR-Black, kVA-Blue)

This analysis further identified the need for reactive power compensation. The existing reactive power (Q) in the system was calculated to be 40.03 kVAR, while the desired reactive power (Q_{new}) to achieve a power factor of 0.95 was estimated at 17.74 kVAR. Therefore, the system required a 22.29 kVAR compensation to improve the power factor to the target level, eliminating penalties and optimizing system efficiency.

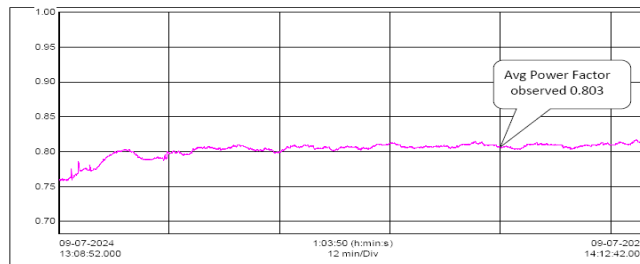

Figure 2: Power Factor

B. Harmonic Analysis and Resonance Mitigation

Harmonic analysis was also critical in determining the APFC system specifications. The power quality audit found current harmonic distortions in the range of 8-9%, although voltage harmonics remained relatively low at 0.2-0.5%. Given the presence of significant current harmonics, simply adding capacitors for reactive power correction could have resulted in resonance issues within the system, potentially amplifying these harmonics and leading to equipment damage.

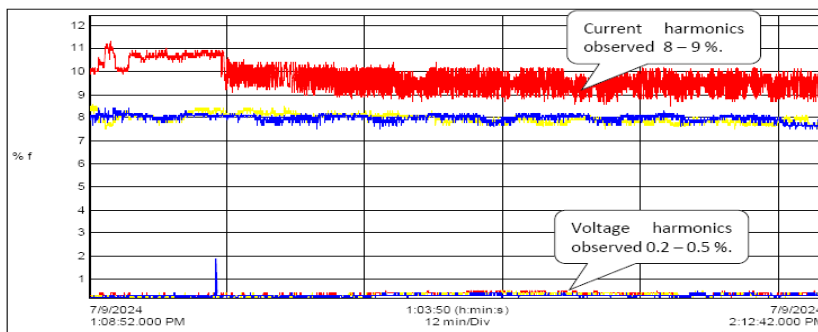

Figure 3: Current & Voltage Total Harmonic Distortion (Athd & Uthd)
(The waveforms show the line current and line voltage)

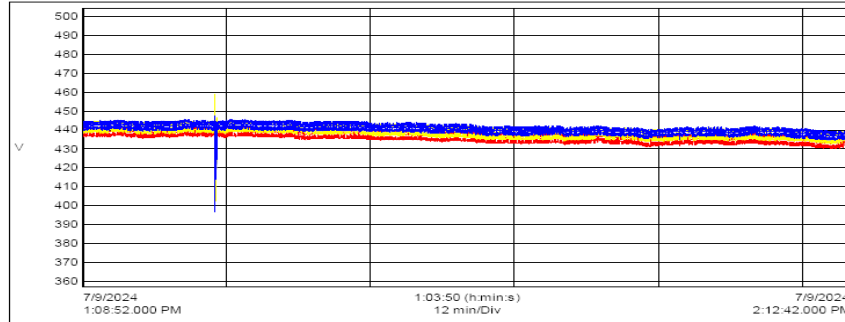

Figure 4: Line Voltage

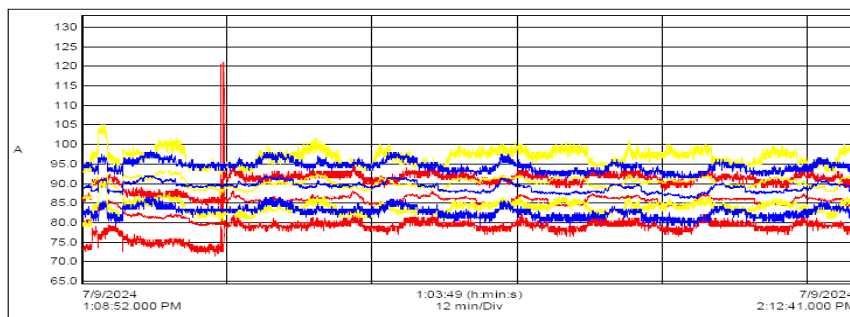

Figure 5: Line Current

C. Mathematical Calculations for the System

Mathematical Calculations for the Proposal of 50 kVAR APFC with 7% Detuned Reactors

Reactive Power Compensation Calculation: The key objective is to improve the power factor from the current level (0.803) to a target value of 0.95 or above. The following steps outline the calculations to determine the required reactive power compensation.

- **Active Power (P):** The active power (real power) measured at the substation is 54 kW.
- **Current Power Factor (PF_{initial}):** The current power factor is measured at 0.803.
- **Target Power Factor (PF_{target}):** The target power factor is set at 0.95.

The apparent power (S) is related to the active power (P) and power factor (PF) by the following equation:

$$S = \frac{P}{PF}$$

Substituting the known values:

$$S_{initial} = \frac{54kW}{0.803} = 67.25kVA$$

The reactive power (Q) is given by:

$$Q = S * \sin(\cos^{-1}(PF))$$

Substituting the values

$$Q_{initial} = 67.25 * \sin(\cos^{-1}(0.803)) = 67.25 * 0.595 = 40.03 \text{ kVAR}$$

For the target power factor of 0.95:

$$S_{target} = \frac{54kW}{0.95} = 56.84 \text{ kVA}$$

The target reactive power to achieve a power factor of 0.95 is:

$$Q_{target} = S_{target} * \sin(\cos^{-1}(0.95))$$

$$Q_{target} = 56.84 * \sin(\cos^{-1}(0.95)) = 56.84 * 0.312 = 17.74 \text{ kVAR}$$

The required reactive power compensation (Q_{comp}) is the difference between the existing and target reactive power:

$$Q_{comp} = Q_{initial} - Q_{target} = 40.03 \text{ kVAR} - 17.74 \text{ kVAR} = \mathbf{22.29 \text{ kVAR}}$$

Thus, the APFC system needs to provide at least **22.29 kVAR** of reactive power to achieve the desired power factor.

A **50 kVAR APFC** system was proposed for the following reasons:

- The system must provide at least 22.29 kVAR of compensation to achieve the target power factor of 0.95.
- The 50 KVAR system provides additional capacity for future load growth or fluctuations in reactive power demand, ensuring that the substation operates efficiently without requiring frequent upgrades.

Since the system exhibits current harmonic distortion in the range of 8–9%, it is essential to mitigate the risk of resonance between the APFC capacitors and system inductance. Detuned reactors are introduced to shift the resonance frequency away from harmonic frequencies.

The resonance frequency (f_r) for a capacitor in series with the system's inductance is given by:

$$f_r = \frac{1}{2\pi\sqrt{LC}}$$

Where:

- L is the inductance of the system,
- C is the capacitance of the capacitor bank.

For practical systems, detuned reactors are rated based on a percentage of detuning, which is typically 7% to avoid resonance at the 5th harmonic (250 Hz). A 7% detuned reactor shifts the resonance frequency below the 5th harmonic. A **7% detuned** reactor ensures that the system's resonance frequency is below the 5th harmonic (250 Hz), avoiding amplification of harmonic currents. The detuned reactor provides inductive reactance to balance the capacitive reactance of the APFC, thereby mitigating harmonic distortion.

The use of detuned reactors in the APFC system ensures that while reactive power is compensated, the harmonic distortion levels are controlled, and the capacitors do not resonate with harmonic frequencies present in the system.

The 50 kVAR APFC system will not provide the full 50 kVAR of reactive power because part of the total capacity is used to offset the inductive reactance of the detuned reactors. The reduction in available kVAR is approximately 7% due to the detuning.

Thus, the effective kVAR provided by the system is:

$$Q_{\text{effective}} = 50 \text{ kVAR} * (1 - 0.07) = 50 * 0.93 = 46.5 \text{ kVAR}$$

This 46.5 kVAR is more than sufficient to meet the required reactive power compensation of 22.29 kVAR, while also accounting for any future fluctuations or load increases. Therefore, the 50 kVAR APFC system with 7% detuned reactors is a suitable solution for the 400kV Waluj Substation, providing sufficient reactive power compensation while avoiding harmonic resonance issues. The system not only corrects the power factor to the desired level of 0.95 but also ensures long-term reliability by mitigating the effects of harmonic distortion. The design approach, including the use of detuned reactors, ensures safe and efficient operation of the substation's electrical system.

V. Simulation of Automatic Power Factor Corrector

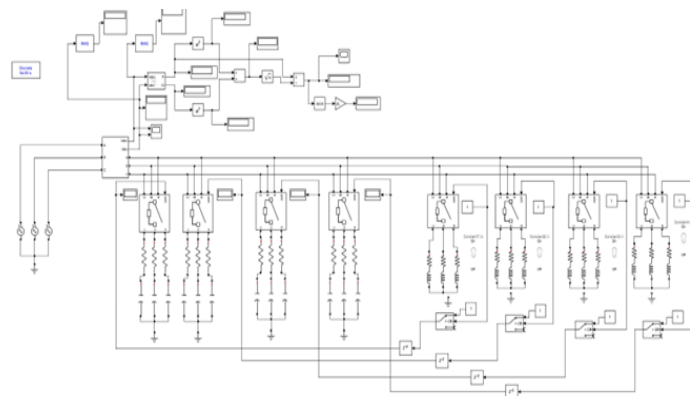

Figure 9: Complete Simulink Model of APFC

A. Working of APFC Model

The MATLAB simulation of the Automatic Power Factor Corrector (APFC) consists of three primary blocks: the Power Factor Calculation Block, the Load Block, and the Capacitor Bank Block. While this model simulates the overall system effectively, it lacks the microcontroller-based automation present in the real-world setup. The following sections describe the workings of each block in detail.

1. Power Factor Calculation Block

The Power Factor Calculation Block is responsible for continuously calculating the power factor of the system in real time. It takes the input voltage and input current along with the measured active power (P) and reactive power (Q). The power factor ($\cos \theta$) is calculated using the relationship between real power, reactive power, and apparent power (S). The formula used is:

$$S = \sqrt{P^2 + Q^2}$$

S is the apparent power, P is the real power, Q is the reactive power. The power factor is then computed as:

$$\text{Power Factor}(\cos\theta) = \frac{P}{S}$$

Additionally, the power angle (θ) is derived by taking the cosine inverse (arccos) of the power factor. This block not only provides the real-time value of the power factor but also displays the phase angle between voltage and current, which is crucial for understanding the system's efficiency and the amount of compensation required.

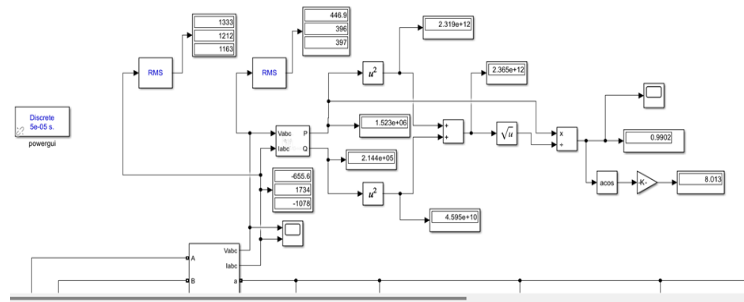

Figure 10: Calculation Block

2. Load Block

The Load Block represents the key loads connected to the substation, which require power factor correction. The loads in the model include:

1. **Cooling systems of 2 transformers:** These represent the cooling mechanism for the substation's transformers.
2. **Yard lighting:** The lighting system for the entire substation yard.
3. **Cooling systems of 2 ICTs (Interconnecting Transformers):** These represent the cooling systems for the ICTs.
4. **Substation air conditioners and Auxiliary:** This block covers the cooling and lighting requirements within the substation building.

Each of these loads is represented by a separate block in the simulation. When a load is connected to the system (indicated by a binary "1"), it represents that the respective load is consuming power. In the simulation, the loads are mostly kept static and do not

change dynamically, which means their power consumption is nearly constant. This is a key limitation of the model since, in the actual system, the microcontroller monitors the real-time reactive power of these loads and adjusts compensation dynamically based on demand.

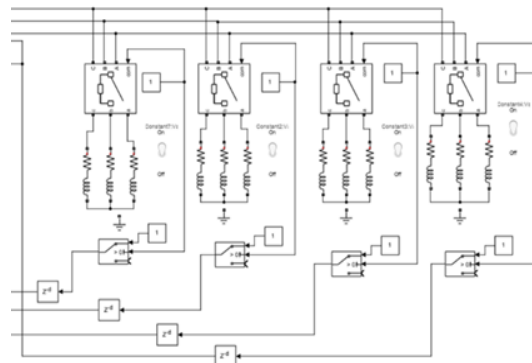

Figure 11: Load Block

3. Capacitor Bank Block

The Capacitor Bank Block is designed to provide reactive power compensation to maintain the power factor close to unity. In the simulation, the capacitor banks are sized to match each load block on a one-to-one basis:

- The first capacitor bank compensates the transformer cooling system.
- The second capacitor bank compensates the yard lighting.
- The third capacitor bank compensates the ICT cooling system.
- The fourth capacitor bank compensates the substation ACs and lighting.

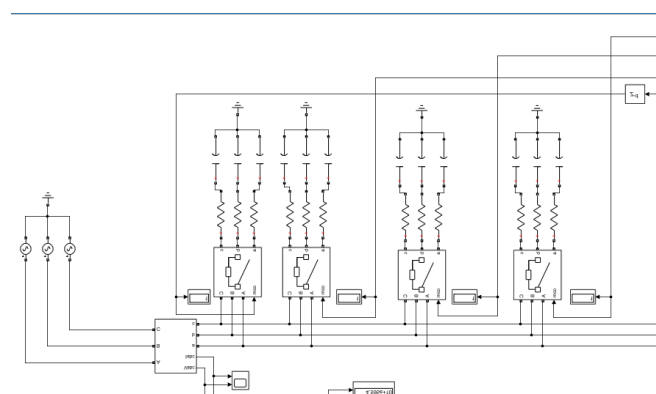

Figure 12: Capacitor Banks Block

The mechanism of compensation in the model is governed by switches that connect or disconnect the capacitor banks based on whether the corresponding load is active. This ensures that each load receives appropriate compensation whenever it is operating. While this switching mechanism is automatic, it is static in design, meaning the system does not dynamically adjust the compensation. In contrast, the real-world APFC system employs a microcontroller that actively monitors the reactive power demand of each

load and switches capacitor banks accordingly. This allows for more efficient compensation, particularly when dealing with fluctuating or nonlinear loads, and ensures that the power factor remains as close to unity as possible under all operating conditions.

VI. Working of the Installed System



Figure 6: APFC Control and Relay Panel

1. Power Factor Monitoring and Control

The APFC continuously monitors the power factor (PF) of the substation through power analysers that measure critical electrical parameters, including active power (P), reactive power (Q), and apparent power (S). Based on these measurements, the system determines the amount of compensation required to bring the power factor closer to the desired level.

2. Reactive Power Compensation

When the power factor falls below the set threshold, the APFC activates a series of capacitor banks to provide reactive power compensation. These capacitor banks are connected to the system based on real-time demand using a microcontroller. The system utilizes a 7% detuned reactor to prevent resonance issues caused by harmonic frequencies, which can lead to system instability. This reactor ensures the capacitor banks operate safely and effectively under varying load conditions, mitigating the risk of harmonic-related failures in the electrical components.



Figure 7: Capacitor Banks of APFC

3. Harmonic Analysis and Protection

The APFC system also incorporates harmonic filtering mechanisms to ensure compliance with IEEE Std 519:2022. Harmonic distortion can cause overheating of equipment such as transformers, cables, and capacitors, leading to potential system failures. The system's detuned reactors ensure that harmonic distortions remain within acceptable limits, protecting the substation's equipment from damage.

4. Controller Functionality

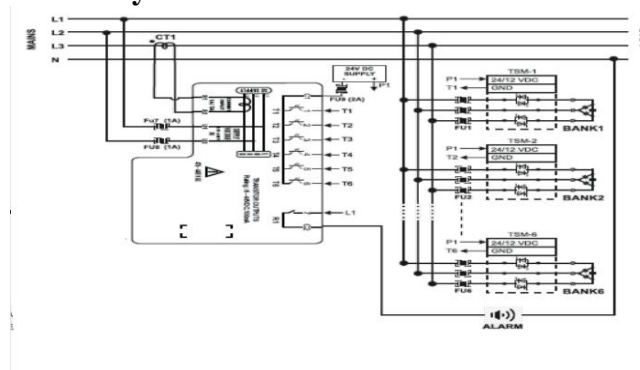

Figure 8: Schematic diagram of APFC from reference no. [4]

Real-Time Monitoring and Adjustment

The controller's primary function is to track real-time data from the power system using current transformers (CTs) and potential transformers (PTs). The controller calculates the power factor by measuring the phase angle between voltage and current.

Dynamic Capacitor Bank Management

When the power factor falls below the desired threshold, the controller connects appropriate capacitor banks to the system to compensate for the lagging reactive power. The system installed at Waluj employs thyristor-based switching modules for capacitor banks, allowing for precise and smooth connection or disconnection without generating transients. The loads at the 400kV Waluj substation, such as ICT cooling systems and yard lighting, can vary throughout the day. This fast and reliable switching minimizes any disruptions to the power system. The controller dynamically adjusts the number of capacitor banks in service to match the reactive power demand of the load.

Stepwise Compensation

The controller offers stepwise compensation, meaning that the capacitor banks are not connected all at once. Instead, they are added incrementally, or in steps, depending on the reactive power demand. For instance, if a load such as the transformer cooling system generates substantial reactive power, the controller will first connect the smallest necessary bank and incrementally add more as needed. This stepwise approach prevents overcompensation and optimizes energy usage.

Advanced Harmonic Filtering and Resonance Prevention

To prevent resonance and handle harmonic distortions, the controller is integrated with a 7% detuned reactor. The controller monitors harmonic distortions continuously and adjusts the compensation, accordingly, ensuring that harmonic levels remain within safe limits as specified by IEEE Std 519:2022.

Alarm and Safety Mechanisms

The controller features LEAD-LAG indicators, alarm notifications, and both manual and automatic modes of operation. In the event of abnormal conditions, such as excessive harmonics or capacitor bank failure, the controller triggers alarms and isolates affected components to protect the overall system.

VII. Economic Assessment of the Installed System

Economic feasibility of installing a 50 KVAR Automatic Power Factor Corrector (APFC) by calculating the Net Present Value (NPV) of the project over 5 years is assessed here

- APFC Cost (Initial Investment): ₹4,50,000.
- Monthly Penalty Charges: ₹15,224.
- Estimated Monthly Savings from Power Factor Correction: ₹15,224 (since the penalties will be eliminated).
- Discount Rate: 10% per year (assuming the cost of capital / inflation rate).
- Time Horizon: 5 years (60 months).
- Operating and Maintenance Costs (O&M): Typically assumed negligible or minimal for the first 5 years but can be considered in future analysis.

Step 1: Net Present Value (NPV) Calculation:

The NPV helps evaluate the present value of future cash flows (savings) generated by the APFC installation. The formula for NPV is:

$$NPV = \sum_{t=1}^{60} \frac{S}{(1+r)^t} - C_0$$

S = Monthly Savings = ₹15,224.

r = Monthly Discount Rate = $\frac{10\%}{12} = 0.833\%$

t = Time in months.

C₀ = Initial Investment = ₹4,50,000.

The Python code to compute NPV is written as below:

```

1 # Initial Investment and Savings
2 Co = 450000 # Initial investment in INR
3 S = 15224 # Monthly savings in INR
4 r = 0.00833 # Monthly discount rate (10% annual)
5
6 # NPV calculation over 5 years (60 months)
7 NPV = 0
8 for t in range(1, 61):
9     NPV += S / (1 + r)**t
10
11 # Subtract initial investment to get net NPV
12 NPV = NPV - Co
13
14 # Display result
15 print(f'Net Present Value (NPV) over 5 years: INR {NPV:.2f}')

```

Output of the following Code:

```

Net Present Value (NPV) over 5 years: INR 266589.56
=== Code Execution Successful ===

```

Figure 13: Python Code along with its output

The Net Present Value (NPV) of installing the 50 KVAR Automatic Power Factor Corrector (APFC) over a 5-year period is ₹2,66,589.56. This positive NPV indicates that the investment is financially viable and will generate significant savings

Step 2: Payback Period

The payback period is the time taken to recover the initial investment through monthly savings:

$$Payback\ Period = \frac{Co}{S} = \frac{450000}{15224} \approx 29.56\ months$$

This means the system will pay for itself in approximately 30 months (2.5 years).

Step 3: Return on Investment (ROI)

ROI measures the total return from the project over 5 years:

Total Savings = 15,224×60 = ₹9,13,440

$$ROI = \frac{Total\ Savings}{Co} \times 100 = \frac{(913440 - 450000)}{450000} \times 100 = 102.98\%$$

The ROI of approximately 103% indicates that the project will more than double the initial investment.

Investing ₹4,50,000 in a 50 KVAR APFC system will generate significant savings by eliminating power factor penalty charges of ₹15,224 per month. The payback period is approximately 2.5 years, and the project is expected to yield a return of Investment over 100% on the initial investment over 5 years. This makes the installation financially viable and beneficial in the long term.

VIII. Discussion

The decision to implement an Automatic Power Factor Correction (APFC) system should be viewed not only from a technical point of view but also through the lens of economic efficiency. For facilities that are frequently charged heavy penalties or tariffs due to low power factor, adopting an APFC system is a financially prudent choice. The penalties imposed can significantly impact the operational expenses of an industrial or commercial setup. From the perspective of Return on Investment (ROI) and Net Present Value (NPV), installing an APFC system offers substantial long-term benefits.

Conclusion

This study shows how installation of the Automatic Power Factor Corrector (APFC) at the 400kV Waluj substation has significantly enhanced the power system's efficiency. The real-world system, controlled by the controller, dynamically adjusts capacitor banks to maintain an optimal power factor, reducing penalties and improving energy usage. The MATLAB simulation provides a conceptual understanding of the APFC operation, demonstrating its effectiveness in reactive power compensation. Although the simulation lacks real-time control, the actual system's microcontroller overcomes this, offering adaptive compensation and harmonic mitigation. Economically, the APFC system has proven beneficial by lowering tariff penalties and reactive power charges, with a quick ROI and a positive NPV over time. Overall, the APFC system improves both the technical performance and financial efficiency of the substation, making it a valuable investment.

References

- [1] Automatic Power Factor Compensation for Industrial Use to Minimize Penalty - Dharmesh J. Pandya, Yogendra Kumar, Dureshwar Pratap Sigh, Dinesh Kumar Vairavel, A. Deepak, A Kakoli Rao, Ajay Rana.
- [2] Automatic Power Factor Measurement and Correction Using MyDAQ - Patthi Sridhar, Ranjith Kumar Gatla, Alladi Sathish Kumar.
- [3] Automatic Power Factor Measurement and Improvement Using Capacitor - Md. Sajidur Rahman, Afroza Memy, Md. Ashik Mahmud, Shahnewaz Siddique.
- [4] Reactive Power Compensation and Current Harmonics Analysis Conducted at M.S.E.T.C.L 400kV Waluj Substation.
- [5] etaSMART APFC Instruction Manual, Laurltz Knudsen.
- [6] A Report on Reactive Power Compensation and Current Harmonics Analysis as per IEEE 519-2014. Conducted at M/S SPADMA PLASTIO ENGINEERING,

PL NO 007

- [7] Power Factor Correction Using APFC Panel on Different Loads - Vinay Sehwal, Vaibhav Dua, Ajendra Singh, Jitendra Nath Rai, Vineet Shekhar.
- [8] Real time implementation of unity power factor correction converter based on fuzzy logic – Abderrahmen Benyamina and Samir Moulahoum.