

Mobile Agent Framework for Web-Advertising

Roopa G M^{1*} and Dr. Nirmala C R²

¹Assistant Professor, ²Prof. & Head

Department of computer Science and Engineering

Bapuji Institute of Engineering and Technology, Davangere-577004.

*E-mail : roopa.rgm@bietdvg.edu , crn@bietdvg.edu

Abstract:

Advertising aims to influence the way customers view products/services and buying certain products of their interest can prove to be beneficial to them. Today, due to the vast technological advances marketing has become very important segment in a business, because of the sheer number of people that access these sites regularly increases. As the number of publisher site increases with the rapid growth in the Internet and World Wide Web, it becomes a difficult task for the advertisers for posting the advertisements on various ad-publisher sites and the customers to make decision on choosing the right products/services. A Mobile Agent based framework for web-Advertising is proposed which performs the task of advertiser for publishing and extends to provide a personalized and dynamic level of advertising than through traditional marketing approach. The system is implemented using IBM's Aglet software Development Kit and MySQL for storage requirements.

Keywords: Advertisers, Ad-Publishers , Aglets, Client/Server, Mobile Agents, Web-Advertising.

1. Introduction

Web-advertising is an increasing business at the internet and it continuously grows together with the expanding use of internet services to deliver the marketing messages to attract the customers. E-Advertising or electronic advertising is advertising, via the internet using website. Examples of online advertising include contextual ads on search engine results pages, banner ads, Social network advertising, and e-mail marketing, including e-mail spam etc.

The internet has become an ongoing emerging source that tends to expand more and more. The growth of this particular media attracts the attention of advertisers as more productive source, to bring in consumers. A clear advantage consumers have with online advertisement is the control they have over the item, choosing whether to check it out or not [15].

Online Advertising Methods:

As the internet becomes an indispensable part of our lives, seeking attention through this electronic medium is an excellent way of riding the wave of business like success. This cheap medium of advertising is the fastest way of making your mark in the market and carving a niche for yourself. Effective advertising methods provide you with the ideal grounds for targeting specific groups [6]. With only a split second to grab attention of the potential consumers, bold advertisements make a quick impression on the internet surfing crowd. Some of the effective online advertising methods are:

- E-Mail Advertising
- Display Advertising
- Affiliate Marketing
- Behavioral Targeting
- Semantic Advertising

Online Advertising Techniques:

- **Content Advertising:**

The first type of advertising technique is content advertising. It basically uses content to draw visitors' attention. It is the main type of advertising technique because the entire internet is made up of content (or information).

The following traffic strategies all fall under content advertising technique:

- Submitting articles to article directories.
- Posting articles to your own blog or content website.
- Press release.
- Paid reviews at other people's website.
- Post videos in video sites.
- Posting comments in forums.

In content advertising, traffic is drawn from two sources. First, from the website where the content is posted or from the search engine. The real challenge lies in getting traffic from the search engine. The aim is to get high ranking in the search engine and direct the traffic from the search engine to the content and then to the website. This is done through careful keyword research and search engine optimization.

- **Link Advertising:**

This type of advertising technique typically uses a short link with some description to attract the visitors directly to your website. The following traffic strategies all fall under link advertising technique:

- Submission to directories.
- Link exchange partnership.
- Banner advertising (image version of link advertising).
- Email signature.

In link advertising, traffic is drawn from just one source that is the existing traffic from the website where the link is posted. The key in link advertising is the OFFER given by the website or the product. Many advertisers expect people to click on whatever link they post. When no one clicks, they wonder why people are not responding.

- **Viral Advertising:**

This kind of advertising technique is similar to word of mouth advertising in the offline world. The idea is to encourage the existing traffic to bring more traffic to the website. The following traffic strategies all fall under viral advertising technique:

- Offer your products' affiliate program, including finding joint venture partners.
- Distribute viral screensaver, software or eBooks.

Success in viral advertising depends a lot on the ability to create a buzz in the community. We need to package the product into something that is unique and interesting so that people are interested in spreading the words for you. Viral advertising can hardly work for a “me-too” product.

- **Incentivized Advertising:**

The forth type of advertising technique is incentivized advertising where the traffic is rewarded to visit the website. The following traffic strategies all fall under incentivized advertising technique:

- Traffic exchange programs.
- Auto-surf advertising.

Success in this type of advertising depends mainly on the offer and the way they present it. Most advertisers who fail either do not have a good offer or they fail to deliver the benefit of their offer across to the target audience.

- **Obtrusive Advertising:**

The last type of advertising technique is obtrusive advertising where the traffic is forced to view the advertisement. The most typical examples are pop-up and pop-under advertising. The first rule in obtrusive advertising is to avoid untargeted traffic, which happens to be quite common in this kind of advertising. If the advertisement is shown to a pool of people who are not interested in the offer, they are simply barking up the wrong tree. If the traffic is targeted, the success in obtrusive advertising depends mainly on the offer and the way they present it, similar to incentivized advertising.

Benefits of Online Advertising:

- Wide Reach
- Target Oriented
- Quick Conversion
- Highly informative

- Cost – Effective
- Easy To Use

The mobile agent approach is a relatively new paradigm in the distributed systems environment. MAs have been developed as an extension to mobile code approach (e.g. applet) and could replace the client-server model and its architectures in the near future. Many researchers in this field have extended the mobile-code concept to “mobile object” in which an object (code + data) are moved from one host to another. The mobile agent approach extends this concept further by moving code, data and state (thread) from one host to another as well. MAs run at one location, move with their state to another host, and continue execution at that host. Mobile code and mobile objects are normally moved by an external entity while MAs are usually migrated autonomously.

Before the mobile agent paradigm appeared, many approaches have been proposed and developed for communication between client and server such as, Message Passing (MP), Remote Procedure Call (RPC) and Remote Evaluation (REV). In RPC, the client sends data as parameters to a procedure that resides at the server. The procedure will be executed on the server and the results will be sent back to the client. The REV is a different architecture from RPC. Instead of calling a remote procedure at the sever side, the procedure itself will be sent from the client to the server to be executed and returns the result. Briefly, in RPC the data is transmitted between the client and server in both directions. In REV, code is sent from the client to the server, and the data is returned. In contrast, a mobile agent is a program (encapsulating code, data, and state) sent by a client to a server.

However, in a client/server model, a server is a machine that provides some service (or a set of services) and a client (most often another machine) makes requests for those services through a communication channel (e.g. wireless or wired). Communication between the client and the server is usually through message passing. Thus, when a client needs a particular service, it usually sends a request message to the server that contains the needed service as shown in figure 1. A limitation of the client-server model is that the client is limited to the operations provided at the server. If the client needs a service that a particular server does not provide, it must find a server that can satisfy the request by sending out more messages to other servers. This clearly is an inefficient use of network bandwidth. In addition, this kind of communication may increase the networks traffic, waste network bandwidth and causes delays of the reply due to server down time or crashes.

Another problem is in the use of the model for disconnected computing. Due to the mobility factor of mobile devices (mobile phones, Personal Digital Assistants (PDAs), Laptops), sporadic disconnection is frequent in the wireless environment. Mobile agents provide a solution for the dynamic environment of the mobile devices because they do not rely on server operations. The mobile agent appears to tackle significant problems whether in wired or wireless communication such as disconnection operations, increased network traffic and others.

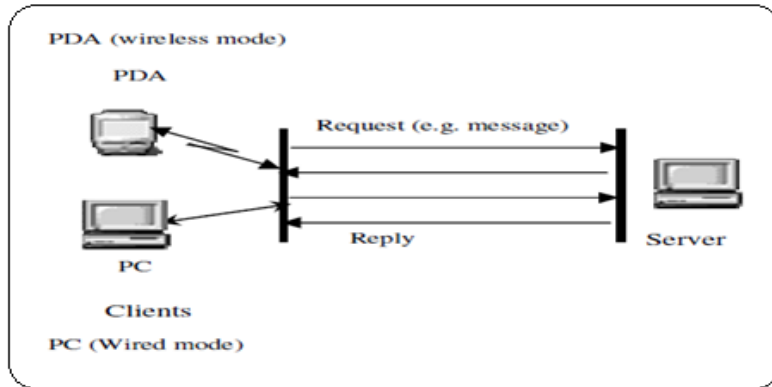

Figure 1: Client – Server Paradigm

Moreover, mobile agents can play a major role in the wireless communication after the failure of the Java RMI in increasing the performance over slow wireless links. Once the mobile agent has migrated, the connection between client and server will be disconnected. This saves network bandwidth, especially in a wireless environment. When a mobile agent finishes its job at the server, it will then be ready to reconnect to its host or to migrate to another node to perform other duties within the network as shown in Figure 2.

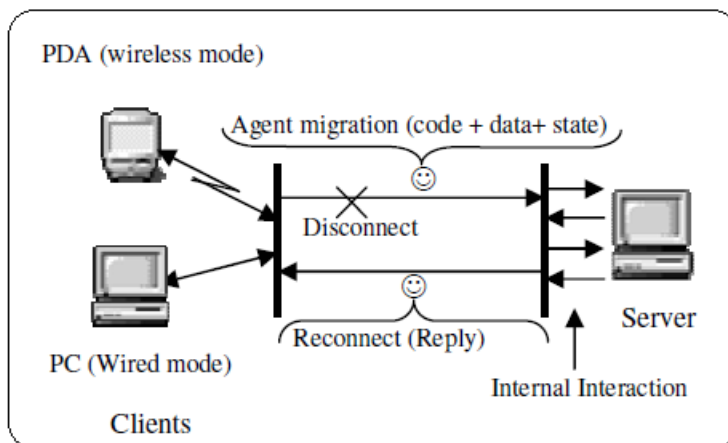

Figure 2: Mobile Agent Paradigm

Mobile agents are implemented using Aglets Software Development Kit (ASDK). Aglets is a Java based mobile agent platform and library that eases the development of mobile agent based applications, and are able to move autonomously and spontaneously from one host to another[3].

Aglet is a library written in Java which was introduced by IBM (International Business Management) to support the development of mobile agent. The execution environment within which Aglets are executed is referred to as the Aglet’s Context and is responsible for enforcing the security restrictions of the mobile agent. The Aglet Life cycle state diagram is shown in Figure 3.

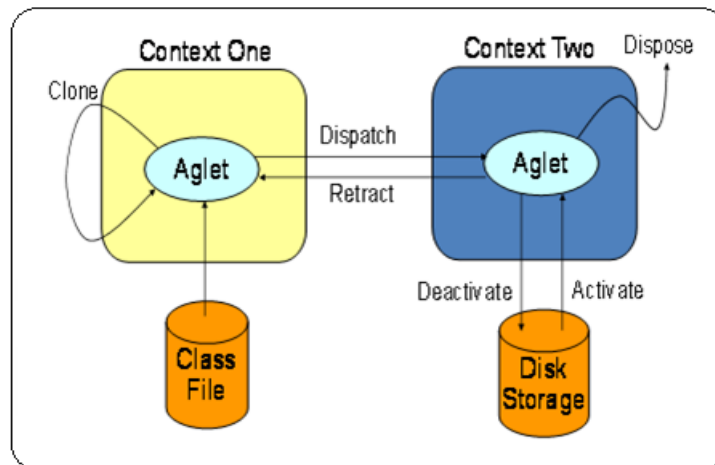

Figure 3: Aglet Life Cycle

Problem Statement:

Online advertisements are used to promote the services and products known to its likely users or consumers in a very easy and dynamic way. Internet has become a major medium where business, organization or establishment could function effectively in a competitive environment. Therefore we can say that advertisements serve as agents between organizations and customers [8]. But the main problem here is posting these advertisements. The affiliates (the people who want to post their ads into websites) have to contact the advertiser manually for posting each and every advertisement. And the affiliates themselves have to take the responsibility in posting these advertisements onto different websites at a time, which is a burden to them. Furthermore posting the advertisements becomes an expensive task and a complicated procedure as the number of ad-publisher sites increases. By considering all the above issues, we have proposed a Mobile agent based architecture that will probably overcome these shortcomings by carrying out automated procedures.

Proposed Solution:

A Mobile Agents framework is proposed to deal with the above mentioned problems. Rather contacting the advertiser manually for each and every time, the affiliates can register to the aggregator to post their advertisements. Later the MAs residing in the aggregator (website) take care of pushing these advertisements automatically onto the different websites at a time, thereby reducing the complexity of the affiliates.

2. Background Theory:

Dikaiakos and Samaras [9] introduced a hierarchical framework for the quantitative performance analysis of mobile agent systems. They specified this framework as a hierarchy of benchmarks, which may enable the characterization of the performance of some of the key components of the mobile agent systems.

They also proposed a set of micro-benchmarks to implement the lower level of their benchmark hierarchy.

Ismail [5] developed a minimal mobile agents platform to measure the cost of the basic Java mechanisms involved in the implementation of the mobile agent platform. They compared the performance of this minimal agent system, Aglets and Java-RMI (representing the client-server paradigm) for two applications namely forward application and compress application

Dewan et al [10] designed a balancing content and advertising model to balancing the amount of advertising and content on a web page in order to manage web sites for profitability. The tradeoff was modeled as a control problem for a web site manager who is maximizing the net present value of cash flows by controlling the amount of advertising and content displayed on the web site over its life.

Zhou et al [16] presented a mechanism for on-line advertisement placement to Deter click fraud. Investigations were made on the principal-agent problem of the on-line advertising market with respect to the publisher, the coordinator, and the advertiser. They categorized the publisher coordinator contract as a double-sided moral hazard problem and the coordinator-advertiser contract as a double moral hazard problem with the agent's effort observed. Their findings were compared to that of the auction-based model.

Goldfarb and Tucker [17] worked on research advertisement based on economic and business dimension. They examined a profitable side of the long tail of advertising that is not possible under the traditional broadcast advertising model. They provided clear empirical evidence of the extent to which advertising context based advertisement has ability to target very narrow markets which provides 'ling tail of advertising' that is not feasible under the traditional broadcast advertising model.

Chickering and Heckerman [11] presented a targeted advertising model on the web using inventory management with the aim that and company who maintains websites can make considerable revenue by running advertisements, which therefore compete to attract advertisers. If advertisers can be attracted when companies deliver high click-through rates on a site which increases revenue directly, consequently, companies can benefit from delivery systems that display advertisements selectively to those visitors most likely to click though. A delivery system that maximizes click-through rate given inventory-management constraints in the form of advertisement quotas was developed.

3. System Overview

Architecture is a process of planning and designing an application or software. Mobile agent architecture to post the online advertisements onto different websites is given in Figure 4.

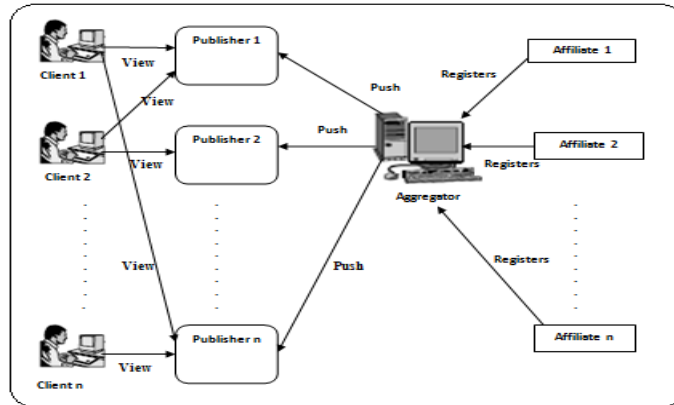

Figure 4: Mobile Agent Architecture for Web-Advertising

Web-advertising with Mobile agents uses a communication model called as push and pull model [12]. The people who want to post his ads onto websites are called as affiliates. The term aggregator refers to a web site or computer software that aggregates a specific type of information from multiple online sources.

Firstly, the affiliate has to register to the aggregator. Later MA's residing in the aggregator pushes these ads into several publisher sites at a time and the interested client will pull these advertisements as shown in above Figure 4.

Based on architecture overview, it includes four modules:

- Affiliate Registration Module.
- MainAglet1 (Affiliator) Module.
- PostAglet1 (Aggregator) Module.
- Publisher Module.

- Affiliate Registration Module:

This module consists of a static agent that remains local to a machine and acts as a host for other agents. In this module, we create login section for the affiliates. Only the registered affiliates are allowed to enter into the aggregator site for posting their advertisements.

- MainAglet1 (Affiliator) Module:

Once the affiliate registers, it starts selecting the advertisements. Finally the chosen advertisements of the affiliate will be posted to the aggregator.

- PostAglet1 (Aggregator) Module:

The module consists of a dynamic agent which takes the responsibility of pushing these advertisements onto different websites (publisher) at a time, thereby reducing the workload of the affiliates.

- Publisher Module :

This module is mainly responsible for displaying the pushed advertisements of the aggregator to the clients.

4. Results and Discussion:

To carryout the task of web-advertising, mobile agents are implemented using Aglets Software Development Kit (ASDK). It provides an object-oriented programming interface, a network agent class loader that enables mobility of agent code, data and state information, an execution context providing a platform-independent development environment.

These Aglets are hosted by an aglet server called “Tahiti-Server”. Tahiti is java application that allows the users to receive, manage, and send aglets to other computers that are running Tahiti. As a final point, the ASDK includes Aglet API packages, documentation, sample aglets, and the Tahiti Server.

Tahiti server will ask the user to authenticate itself, showing a window with fields for username and password. The default username is “aglet_key” and password is “aglets” as shown in figure 5(a). Once the user has logged in, the Tahiti main window is displayed which is shown in figure 5(b). Within this window the user can manage the server, creating and disposing agents, getting information, and so on.

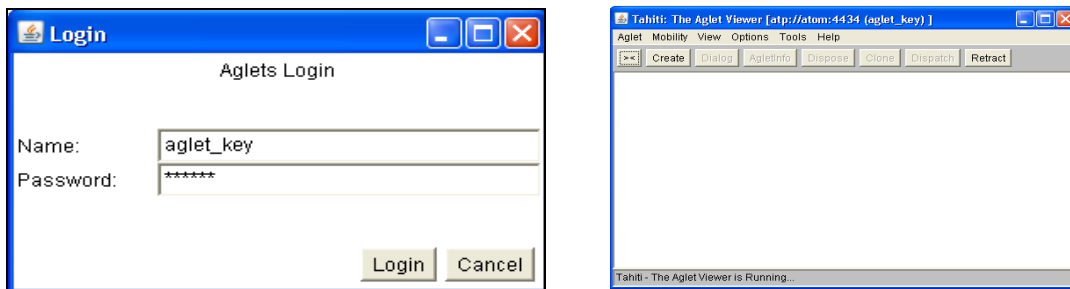

Figure :5(a) Login Window of Aglets 5(b) Tahiti Server Window

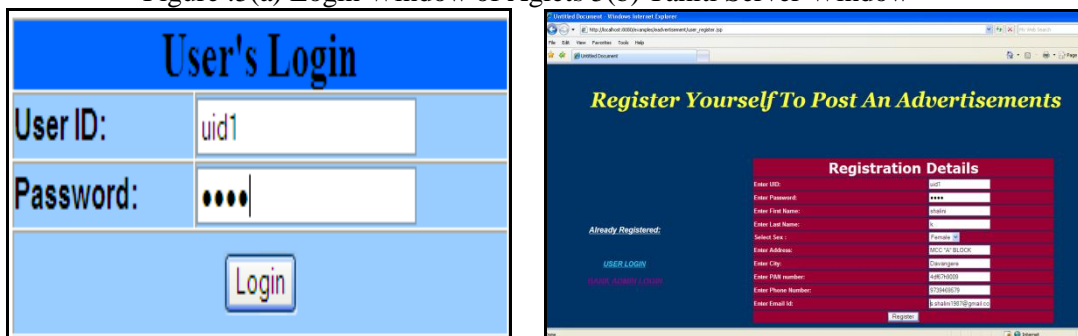

Figure 6(a) Login Window of the User 6(b) Affiliate Registration Form

If the user is already registered, then the user can directly login with the link provided on the left side. But if the registered user does not have a bank account, then the user

has to open the bank account by consulting the bank administrator. Figure 6(b) shows the “Affiliate Registration Form”. In order to post the advertisements onto the different websites at a time, the affiliate has to register to the aggregator with user ID, password, name etc.

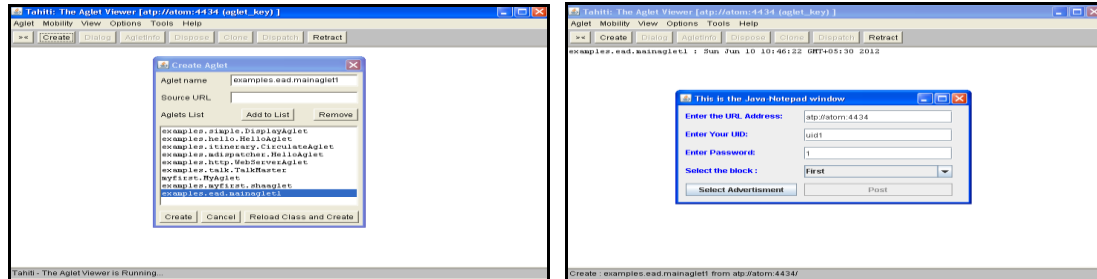

Figure 7(a) Creation of a Mobile agent 7(b) Advertiser Preference window

Once the user logs into the aglet, the Tahiti server runs. Later the user clicks the button “create” and selects the aglet i.e. “examples.ead.mainaglet1” and creates mobile agent shown figure 7(a). Once “examples.ead.mainaglet1” agent is created a popup window appears shown in figure 7(b). At this juncture, the user enters the URL Address, Uid, and Password and also selects the block where the advertisement has to be posted.

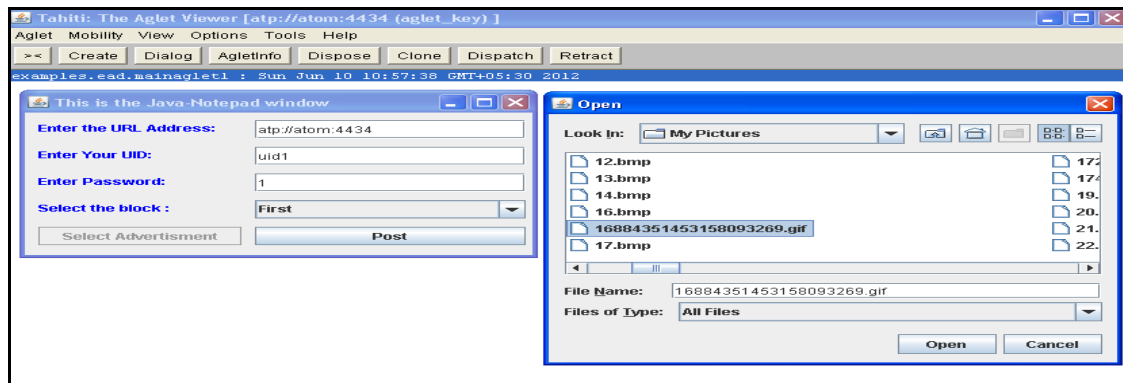

Figure 8: Selection of an Advertisement for posting

Once all the details of popup window are enrolled, the user clicks the button “Select Advertisement”. Now a new window appears and the user chooses the advertisement as shown in Figure 8. Later the selected advertisement will be posted to the aggregator.

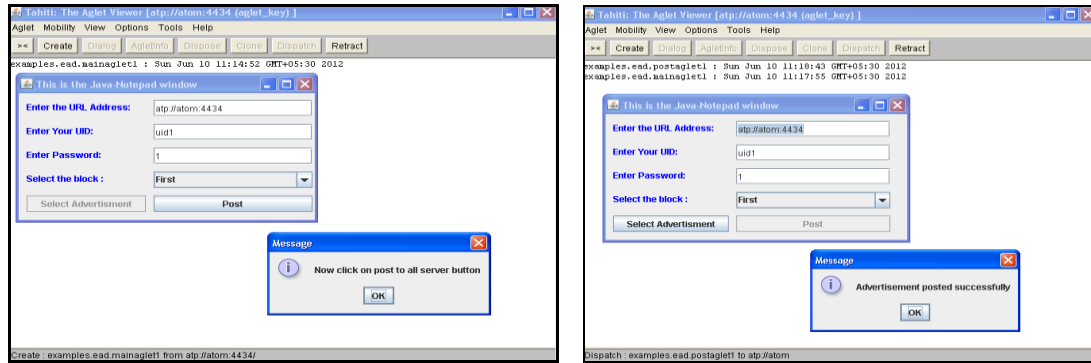

Figure 9(a): Mobile Agents loaded with advertisements for posting 9(b) successfully posted the advertisements

On selection of the advertisement, “Now Click on Post to All Server Button” message will be generated by an aglet as shown 9(a). Once the post button is clicked, “examples.ead.postaglet1” will be created and executed automatically and finally “Advertisement posted successfully” message will be generated by an aglet as shown in a figure 9(b).

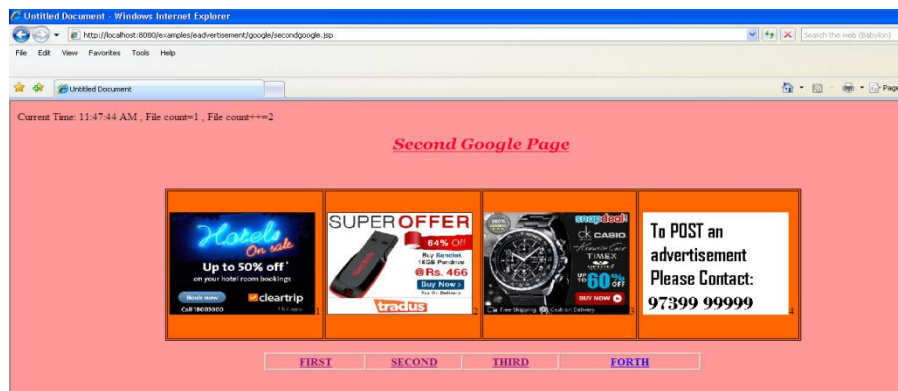

Figure 10: Advertisements successfully posted on the target web-page.

Once the “Advertisement Posted Successfully” message is displayed by the aglet, then instantaneously the advertisement will be displayed on the respective webpage as shown in the above Figure 10.

5. Conclusion

In this work, an Agent-based Framework for Personalized web-Advertising is proposed which performs the task of posting the advertisements on to various ad-publisher sites simultaneously. It offers a flexible, extensible and scalable framework and allows users to quickly access to the advertisements which are more close to their interest. In addition, saves users time and bandwidth in the ad-publishing process when compared to that of the traditional approach. At last we conclude that “The MA Concept of Online Advertising” allows the affiliates sitting at any corner of world to

post their advertisements online with a single click, and can also change or update their advertisements based on the number of views and clicks.

Future scope:

- With a single user ID, the affiliates can be allowed to post a numerous advertisements at a time in a multiple web-pages.
- The affiliates are permissible to post not only banner and wallpaper advertisements but also video, pop – up and mobile advertisements.
- When the end user or client clicks on the advertisements, the mobile agents must open the corresponding window and should allow the clients to shop the posted items or goods.

References:

[1] N. R. Jennings and M. J. Wooldridge, "Applications of Intelligent Agents" in Agent Technology: Foundations, Applications, and Markets, pp. 3-28, 1998.

[2] Dag Johansen, "Mobile Agent Applicability", Proceedings of the Mobile Agents 1998, Berlin, Springer- Verlag, Lecture notes in computer science; vol. 1488, ISBN 3-540- 64959-X, pp. 9-11, September 1998.

[3] Lange D. B. and Oshima M., "Programming and Deploying Java Mobile Agents with Aglet", Addison-Wesley, Longman, Reading, MA, U.A.S, 1998.

[4] Danny B. Lange and Mitsuru Oshima, "Seven Good Reasons for Mobile Agents", Communications of ACM, vol. 42, no. 3, March 1999.

[5] L.Ismail, D.Hagimont, "A Performance Evaluation of the Mobile Agent Paradigm", Proceedings of the Conference on Object Oriented Programming, Systems, Language and Applications, pp. 306-313, 1999

[6] X.Yi, C.K.Siew, X.F.Wang, E.Okamoto, "A Secure Agent Based Framework for Internet Trading In Mobile Computing Environments", International Journal of Distributed and Parallel Databases, Vo1.8, No.1, January 2000.

[7] Ravi Jain. , Farooq Anjum., Amjad Umar., "A Comparison of Mobile Agent and Client-Server Paradigms for Information Retrieval Tasks in Virtual Enterprises", 2000.

[8] David Siew, Xun Yi, "Agent-Mediated Internet Advertising", Second International Workshop on Advance Issues of E-Commerce and Web-Based Information Systems(WECWIS), pp. 102, 2000.

- [9] M. Dikaiakos and G. Samaras, “Quantitative Performance Analysis of Mobile-Agent Systems: A Hierarchical Approach”, Revised Papers from the International Workshop on Infrastructure for Multi-Agent Systems, pp.180-188, 2000.
- [10] Dewan.R, Freimer.M, & Zhang.J, “Managing Web Sites for Profitability: Balancing Content and Advertising”, Proceedings of the 35th Annual Hawaii International Conference on System Sciences (HICSS'02), Vol. 8, p.181, 2002.
- [11] Chickering D.M., and Heckerman.D, “Targeted Advertising on the Web with Inventory Management Interfaces”, 33(5), pp. 81-88, 2003.
- [12] Yang Zhao, “A Model of Computation with Push and Pull Processing”, University of California at Berkeley, 2003.
- [13] Freund.A, and Naor .J, “Approximating the Advertisement Placement Problem”: Journal of Scheduling, 8(5), pp. 365-384, 2004.
- [14] Sandeep D., and Raghavan N. R. S., “Allocation of Advertising Space by Web Service Provider Using Combinatorial Auctions”, pp. 213–230, 2005.
- [15] Marcus Edvardsen, “ Online Advertisement Management Program (OAMP) ”, Master thesis in Master Of Science In Computer Communication And Networking, Lulea University Of Technology, 2006.
- [16] Zhou.W., Bandyopadhyay. S.,Cheng. H., & Pathak. P “A Mechanism for Online Advertisement Placement to Deter Click Fraud”, International Journal of Electronic Commerce, 13(2), 9-28, 2008.
- [17] Goldfarb.A, and Tucker.C, “Economic and business dimensions search engine advertising”, Communications of the ACM, pp. 22-24, 2008.

