

Modeling and Performance Study of Single Phase Induction Motor in PV Fed Pumping System using MATLAB

¹N. Chandrasekaran and ²K. Thyagarajah

¹*Associate Professor, PSNA College of Engg. & Tech.,
Dindigul, Tamilnadu, India.*

E-mail: chandrasekaran283@gmail.com

²*Principal, KSR College of Tech., Tiruchengode, Tamilnadu, India*

E-mail: drkt52@gmail.com

Abstract

Water pumping using AC motors has become one of the most feasible photovoltaic (PV) applications. Moreover, PV pumping is getting more attention in recent days mainly in remote areas where connection to the grid is technically not possible. Power generation by Photovoltaic is reliable. The operation and maintenance costs are low. The induction motor is more rugged, and maintenance-free motor. In this paper, a PV fed water pumping system using single phase induction motor has been considered. The modeling of PV cell, Boost converter, inverter and single phase induction motor have been studied and developed. The overall AC pumping system fed by PV cell has been simulated using MATLAB and the results are obtained. The results show the performance of a single-phase induction motor drive supplied by a photovoltaic generator.

Keywords: Photovoltaic; Pumping system; Modelling; Matlab

Introduction

Photovoltaic is being employed around the whole world in most recent years. It is widely used in many applications in islands and remote areas. Using photovoltaic as the power source for water pumping is considered as one of the most promising areas of PV application [1]. PV water pumping systems generally consist of PV array, controller, motor, pump and water storage tank [2]. Photovoltaic water pumping systems are particularly suitable for water supply in remote areas where the electricity

is not available. Water can be pumped during the day and stored in tanks, making water available also at night or when it is cloudy. The pumped water can be used in many applications such as domestic use, water for irrigation and village water supplies.

The advantages of using water pumps powered by photovoltaic systems include low maintenance, ease of installation, reliability and the matching between the powers generated and the water usage needs. In addition, water tanks can be used instead of batteries in photovoltaic pumping systems. Pumping schemes driven by d.c. motors suffer from maintenance problems. A pumping system based on an induction motor can be an attractive proposal where reliability and maintenance-free operation is important [6]. In this paper, a pumping system based on an induction motor driven by a voltage source inverter has been considered. The induction motor based photovoltaic pumping system offers an alternative for a more reliable and maintenance free systems [11].

In addition, recent advances in the field of solid state devices, logic circuits and control theory have given a great impetus to the use of single phase induction motors in PV systems [3]. The schematic diagram of pumping system using single phase induction motor fed by PV cell is shown in fig.1. The system consists of a PV array, a d.c.-d.c, converter, a voltage source inverter, and the induction motor coupled to a centrifugal pump. The pump is to convert the mechanical energy into hydraulic energy. Here, the AC pumping system powered by PV cell is simulated using MATLAB and the performance of a single-phase induction motor drive is obtained.

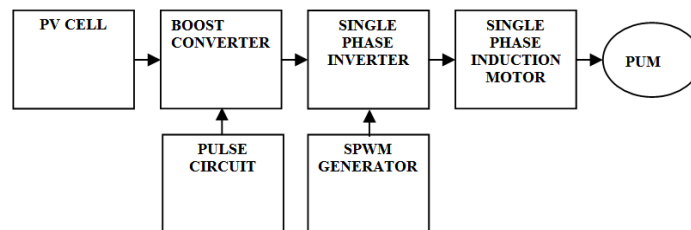

Figure 1: PV fed AC pumping system

PV Cell Model

The physics behind photovoltaic is helpful in understanding the equivalent circuits used to model it. Photovoltaic cells are semiconductor devices; the vast majority of commercial PV cells are fabricated from silicon [4]. A PV cell is essentially a large diode that produces a voltage when exposed to incident light. It may be considered to be a light-emitting diode “run backward;” the analogy is similar to a heat engine and a refrigerator [8]. The PV generator is a non-linear device and is usually described by its equivalent circuit and the I-V characteristics, shown in fig. 2 and fig. 3. The electrical model of a solar cell is composed of a diode, two resistances and a current generator. The relationship between the voltage V (V) and the current I (A) is given by

$$I = I_L - I_0 \left(\exp \frac{V + IR_s}{A} - 1 \right) - \frac{V + IR_s}{R_p} \tag{1}$$

where I_L , I_0 and I are the photocurrent, the inverse saturation current and the operating current, R_s and R_p are series and parallel resistances, respectively, which depend on the incident solar radiation and the cell temperature. $A = kT/q$ is the diode quality factor. k and q are Boltzmann constant and electronic charge respectively. Townsend (1989), Eckstein (1990), Al-Ibrahimi (1996), propose the model with four parameters assuming that the parallel resistance is infinite so (1) can be rewritten as

$$I = I_L - I_0 \left(\exp \frac{V + IR_s}{A} - 1 \right) \tag{2}$$

The current and the voltage parameters of the PV generator are: $I_{pv} = I$ and $V_{pv} = n_s N_s V$, where n_s , N_s are the numbers of series cells in the panel and of the series panels in the generator. The PV generator consists of solar cells connected in series and parallel fashion to provide the desired voltage and current required by the load [7].

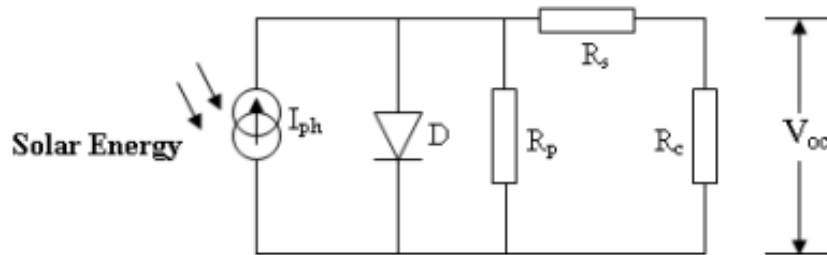

Figure 2: Equivalent circuit of PV cell

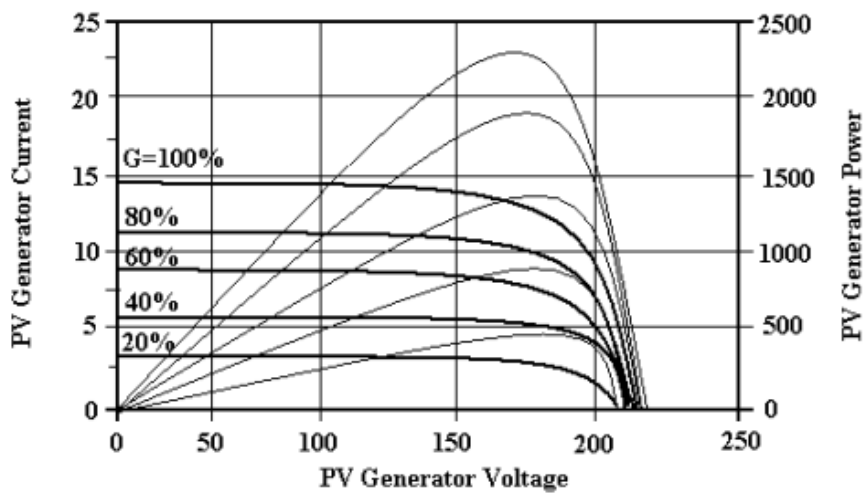

Figure 3: VI Characteristics of PV Generator

Now only the four parameters I_L , I_O , R_S and A need to be evaluated, a method to calculate these parameters has been developed by Townsend (1989) and Eckstein(1990), Duffie and Beckman (1991).

The fig. 3 shows typical I-V characteristics for increasing insolation levels of the used PV array. The short circuit current varies in proportion to the insolation level, while the open circuit voltage is approximately constant [5]. Consequently, the extracted electric power will increase accordingly. Each curve has a maximum power point, which is the optimal operating point for an efficient use of the solar array.

Boost converter Model

Boost converter is a power electronic circuit which gives the output voltage which is greater than the input voltage. It consists of dc input voltage source V_s , boost inductor L , controlled switch S , diode D , filter capacitor C , and load resistance R . [10] When the switch S is in the on state, the current in the boost inductor increases linearly and the diode D is off at that time and at the same time inductor stores the energy. When the switch S is turned off, the energy stored in the inductor is released through the diode to the output RC circuit. Now the output voltage is sum of input voltage and the inductor voltage. The circuit diagram of boost converter is shown in Fig. 4.

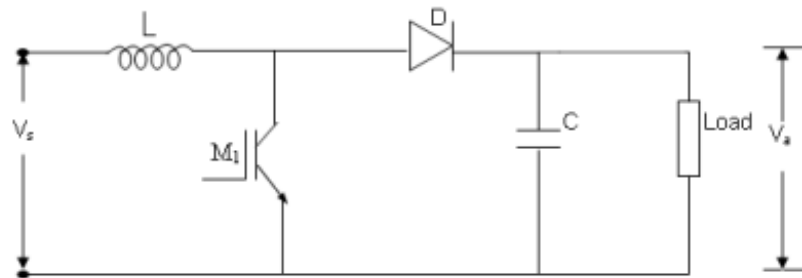

Figure 4: Circuit diagram of Boost Converter

Using Faraday's law for the boost inductor

$$V_s kT = (V_o - V_s)(1 - k)T \quad (3)$$

from which the dc voltage transfer function turns out to be

$$M_v = \frac{V_o}{V_s} = \frac{1}{1 - k} \quad (4)$$

As the name of the converter suggests, the output voltage is always greater than the input voltage. The boost converter operates in the CCM for $L > L_b$ where

$$L_b = \frac{(1 - k)^2 kR}{2f} \quad (5)$$

where k , is the duty ratio of dc to dc converter which is defined as the ratio of turn on time to that of total time. The boost converter steps up the voltage from pv array to the required value before feeding to the pumping system.

Inverter Model

Voltage source inverters are widely used in power supplies, power quality controllers, renewable energy, marine and military applications. If the input dc is a voltage source, the inverter is called a Voltage Source Inverter (VSI). The simplest dc voltage source for a VSI may be a battery bank or a solar photovoltaic cells stack. They are at the heart of applications requiring an AC supply from a DC source [9]. Therefore, it is important that they are designed to be robust and efficient, especially in remote areas and renewable energy applications. Fig. 5 shows the circuit topology for a full bridge inverter. It is an electronic power converter that is necessary as an interface between the power input and the load. The full bridge single phase inverter consists of the DC voltage source, four switching elements G1, G2, G3 and G4 and load. The switching element available nowadays, such as bipolar junction transistor (BJTs), gate turn off thyristor (GTOs), metal oxide semiconductor field effect transistors (MOSFETs), insulated gate bipolar transistors (IGBTs), metal oxide semiconductor controlled thyristor (MCT's) and static induction transistors (SIT's) can be used as a switch[9]. The full bridge single phase inverter has two legs, left or right or 'A' phase leg and 'B' phase leg. Each leg consists of two power devices (here MOSFET) connect in series. The load is connected between the midpoints of the two phase legs. Each power control device has a diode connected in anti-parallel to it.

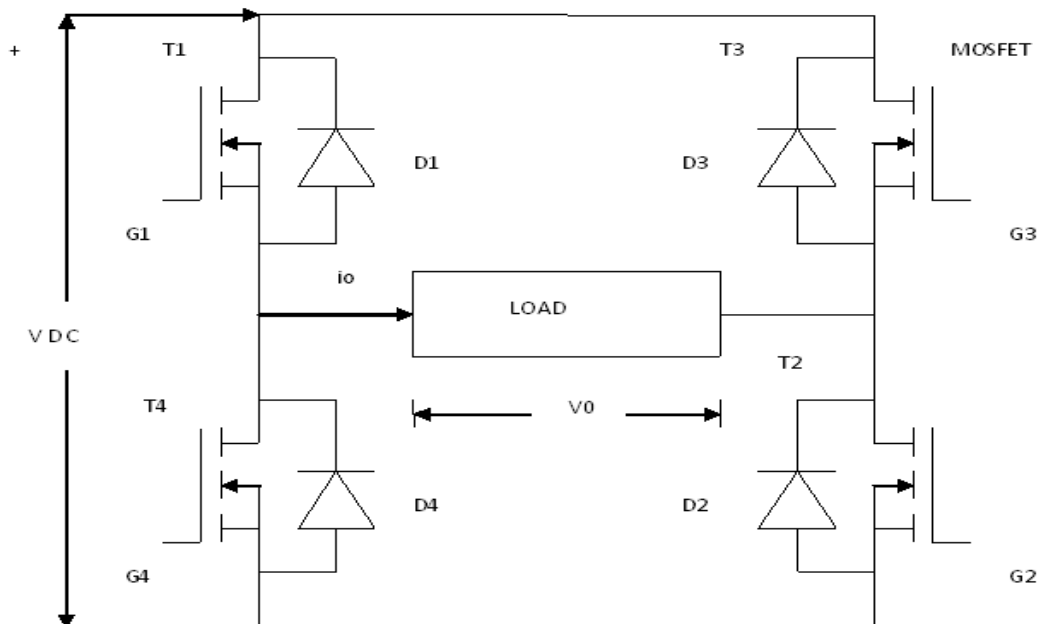

Figure 5: Circuit diagram of Single phase Inverter

The diodes provide an alternative path for the load current if the power switches are turned OFF. For example, if lower MOSFET in the 'A' phase leg is conducting and carrying current towards the negative DC bus, this current would 'commutate' into the diode across the upper MOSFET of the 'A' phase leg, if the lower MOSFET is turned OFF. Control of the circuit is accomplished by varying the turn on time of the upper and lower MOSFET of each inverter leg with the provision of never turning ON both at the same time, to avoid a short circuit of DC bus. The control pulse to the swatches may be generated by either microcontroller or DSP.

The rms output voltage can be found from

$$V_o = \left(\frac{2}{T_o} \int_0^{T_o/2} V_s^2 dt \right)^{1/2} = V_s \quad (6)$$

A variable voltage can be obtained by varying the input dc voltage and maintaining the gain of the inverter constant. On the other hand, if the dc input voltage is fixed then variable output voltage can be obtained by varying the gain of the inverter. This can be accomplished by Pulse Width Modulation-PWM control within the inverter. PWM means the width of the square pulse in positive and negative halves can be adjusted according to the rms of the output required. The inverter gain may be defined as ratio of the ac output (rms) voltage to dc input voltage. Here, the input to the inverter is supplied from boost converter and expected output voltage is 230V.

Induction Motor Model

The equivalent circuit of the induction motor based on double revolving field theory is shown in Fig. 6 where 'a' is the turns ratio of the auxiliary to main winding, R_{lm} , X_{lm} are the resistance and reactance of the main winding, R_{la} , X_{la} are the resistance and reactance of the auxiliary winding, R_c , X_c are the equivalent series resistance and reactance of the capacitor, R_f , X_f are the forward equivalent series resistance and leakage reactance of the rotor referred to the main winding, R_b , X_b are the backward equivalent series resistance and leakage reactance of the rotor referred to the main winding, I_m , I_a , I are the main, auxiliary and motor currents, respectively, E_{fm} , E_{bm} are the self induced voltages in main winding by its forward and backward fluxes, respectively, aE_{fm} , aE_{bm} are the mutually induced voltages in auxiliary winding by its forward and backward fluxes of the main winding, respectively, E_{fa} , E_{ba} are the self induced voltages in auxiliary winding by its forward and backward fluxes, respectively, E_{fa}/a , E_{ba}/a are the mutually induced voltages in main winding by its forward and backward fluxes of the auxiliary winding, respectively[13].

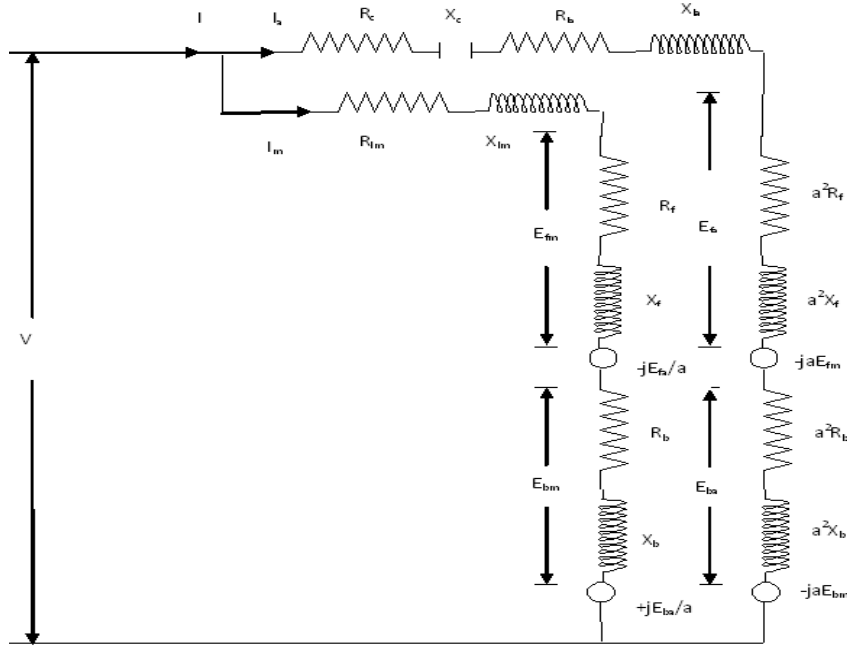

Figure 6: Equivalent circuit of Induction Motor

From fig. 6, the following equations are written

$$V = Z_{lm}I_m + E_{fm} + E_{bm} - jE_{fa}/a + jE_{ba}/a \quad (7)$$

$$V = (Z_{la} + Z_c)I_a + E_{fb} + E_{ba} + jaE_{fm} - jaE_{bm} \quad (8)$$

where,

$$E_m = Z_f I_m = I_m (R_f + jX_f) \quad (9)$$

$$E_{bm} = Z_b I_m = I_m (R_b + jX_b) \quad (10)$$

$$E_{fa} = a^2 Z_f I_a = a^2 I_a (R_f + jX_f) \quad (11)$$

$$E_{ba} = a^2 Z_b I_a = a^2 (I_a (R_b + jX_b)) \quad (12)$$

Substituting from equations (9)-(12) into equations (7) and (8) gives

$$V = (Z_{lm} + Z_f + Z_b)I_m - ja(Z_f - Z_b)I_a \quad (13)$$

$$V = ja(Z_f - Z_b)I_m + (Z_{la} + Z_c + a^2(Z_f + Z_b))I_a \quad (14)$$

The solution of equations (13) and (14) gives the main and auxiliary winding currents under any operating conditions. Hence, the total motor current is obtained as

$$I = I_m + I_a \quad (15)$$

The net amount of power transferred across the air gap is obtained as

$$P_g = (I_m^2 + a^2 I_a^2)(R_f - R_b) + 2aI_m I_a (R_f + R_b) \sin(\theta_a - \theta_m) \quad (16)$$

Where θ_m and θ_a are the phase angles of the main and auxiliary winding currents, respectively.

The electro mechanical torque developed is

$$T_{md} = P_g / \omega_s \quad (17)$$

Where ω_s is the synchronous speed in rad/sec.

The mechanical power developed is given by

$$P_{md} = (1 - S)P_g \quad (18)$$

where S is the per unit slip.

The output power is

$$P_o = P_{md} - P_{rot} \quad (19)$$

Where, P_{rot} is the rotational losses.

The voltage equations (13) and (14) constitute the steady state mode of the single phase induction motor. The solution of these equations under any operating conditions gives the main and auxiliary winding currents. Hence, all the performance characteristics of the motor at particular load point can be calculated. It should be noted that particular load point means a given value for the applied voltage and motor speed.

Centrifugal Pump Model

There are two types of pumps commonly used for water-pumping applications. One is positive displacement pump and another is centrifugal pump. Displacement pumps have water output directly proportional to the speed of the pump, but almost independent of head. These pumps are used for solar water pumping from deep wells or bores[9]. Centrifugal pumps are used for low-head applications, especially if they are directly interfaced with the solar panels. Centrifugal pumps are designed for fixed-head applications, and the pressure difference generated increases in relation to the speed of the pump[10]. These pumps are of the rotating impeller type, which throws the water radially against a casing shaped so that the momentum of the water is converted into useful pressure for lifting [12]. The centrifugal pumps have relatively high efficiency, but it decreases at lower speeds, which can be a problem for a solar water-pumping system at times of low light levels. In fact, in the case of the centrifugal pumps, the operation takes place for longer periods even for low insulation levels, and the load characteristic is in closer proximity to the PV maximum power

locus. Any pump is characterized by its absorptive power which is obviously a mechanical power on the shaft coupled to the pump, which is given by [5]

$$P = \frac{\rho g H Q}{\eta} \tag{20}$$

Useful power: power consumed of the absorptive power is given by

$$P_u = \rho g H Q \tag{21}$$

where η , the total output; ρ , density (Kg/m^3); G , acceleration of gravity (m^2/S); H , height of rise (m); Q , flow(m^3/S).

Simulation Circuit and Results

The simulation circuit model of AC pumping system fed by photovoltaic array is shown in Fig. 7. The solar cell is generating 40V. The output voltage from the solar array is increased to the required level by means of boost converter. The output voltage from boost converter is 230V. As the number of switches in the boost converter is less; it is economical when comparing with other type of dc to dc converters. Here, the MOSFET based boost converter is used which is powered by PV array. The PWM technique is used to generate the triggering pulse to the MOSFET. The Micro controllers or DSPs can be used to generate the triggering pulses practically to the swithes of boost converter and the inverter.

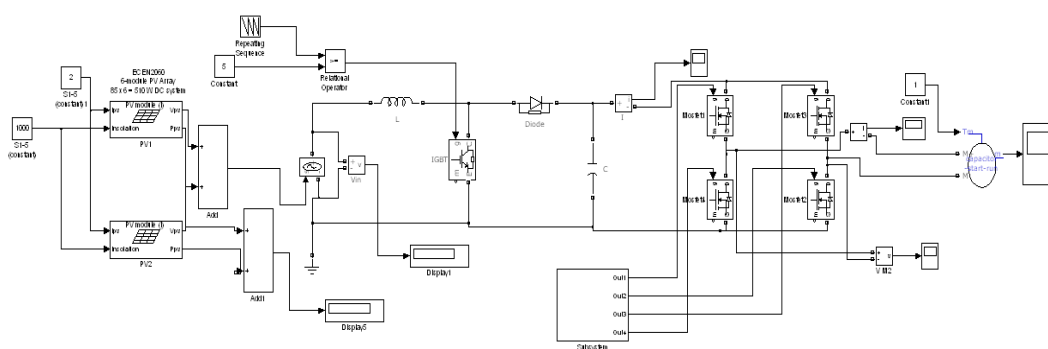

Figure 7: Simulation circuit model of AC pumping system

The output current and voltage of the boost converter are shown in the Fig. 8 and Fig. 9 respectively. The high efficiency, non pulsating input current, high peak transistor current and output voltage sensitive to duty ratio are some features of boost converter. The output of the boost converter is given as input to the single phase bridge type inverter. The output voltage of the inverter is 230V. The output voltage of the inverter is shown in the Fig. 10. The output of the inverter is fed to the AC motor to which the centrifugal pump is coupled.

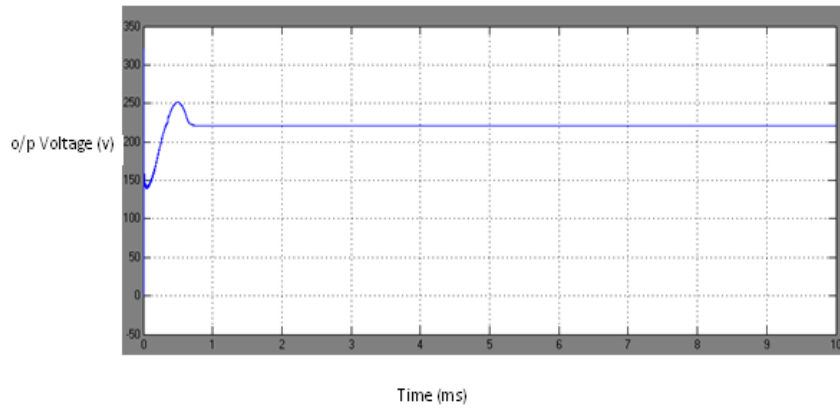

Figure 8: Output current of boost converter

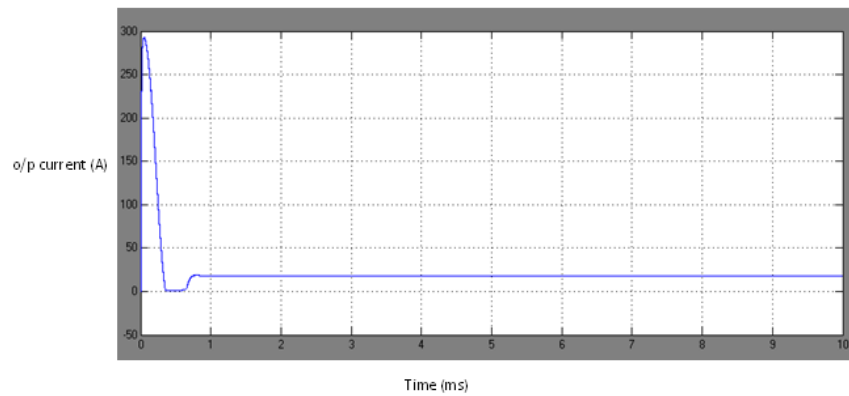

Figure 9: Output Voltage of boost converter

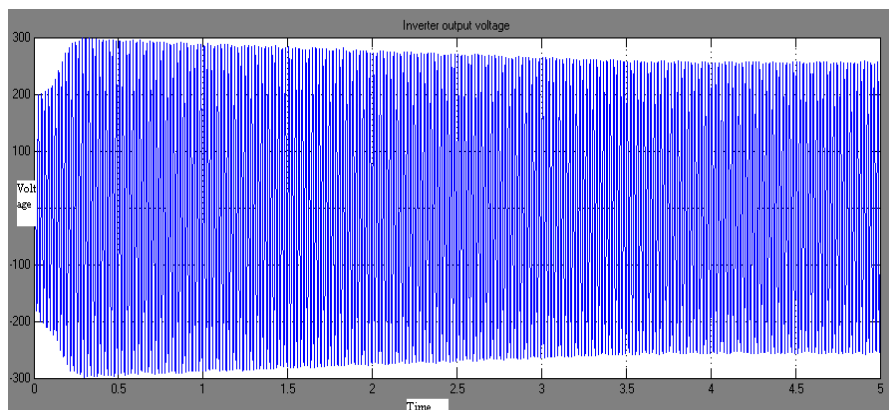

Figure 10: Output Voltage of Inverter

The centrifugal pump with 20m head is selected for this work. The ratings of single phase induction motor are as follows.

Table 1: Specifications of Single phase induction motor.

Parameters	Value
Power	0.5 hp
Voltage	230v AC
Current	1.5 A
speed	3000 rpm

The simulation results give the idea to go for the experimental set up of the ac pumping system. In remote areas where the power supply from grid is not possible, this type of pumping system is more suitable. The water can be stored in the tanks for the use at night time. Or otherwise the energy can be stored in the battery and may be utilized when the sunlight is absent. This kind of solar based pumping system is more efficient for low power applications.

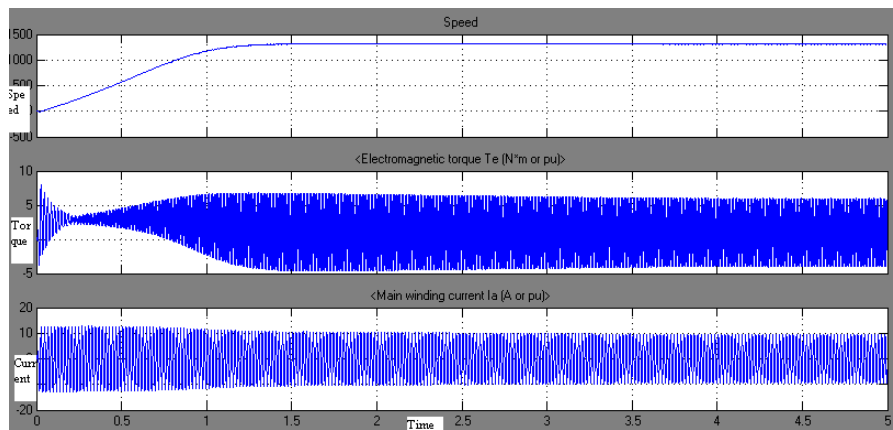

Figure 11: Simulation outputs for speed, armature current and torque

The simulation outputs of single phase induction motor are shown in fig.11. The speed, torque and current output of the induction motor clearly indicates that it is very much suitable for ac pumping system.

Conclusion

The work simulated in this paper examines the possibility of utilizing a PV cell to supply a single-phase induction motor through a single-phase bridge inverter. The system explained here is a PV system for water pumping, using a single phase inverter and single phase induction motor. We can conclude that this work will be a contribution to the analysis of the photovoltaic pumping system with regards to the results of simulation of the model. This paper also investigates a photovoltaic powered AC motor drive for water pumping application and rural electricity. A

number of experimental PV powered DC motor drives for water pumping are already in use, however such schemes find limited applications due to high cost and maintenance problems commonly associated with DC machines. The experimental setup and its analysis may be considered as the future work.

References

- [1] Nejib Hamrouni, Moncef Jraidi, Adnene Cherif Theoretical and experimental analysis of the behavior of a photovoltaic pumping system Science direct, Solar Energy 83 (2009); 1335–1344 .
- [2] Odeh I, Yohanis YG, Norton B. Influence of pumping head, insolation and PV array size on PV water pumping system performance .Solar Energy 80 (2006) ;51–64.
- [3] A Betka, A. Moussi Performance optimization of a photovoltaic induction motor pumping system Science direct, Renewable Energy 29 (2004) 2167–2181.
- [4] Benlarbi K, Mokrani L, Nait-Said MS. A fuzzy global efficiency optimization of photovoltaic water pumping system .Science direct, Solar Energy 77 (2004); 203–216.
- [5] Arrouf M, Ghabrour S. Modelling and simulation of a pumping system fed by photovoltaic generator within the Matlab/Simulink programming environment. Science direct, Desalination 209 (2007) ;23–30.
- [6] Nang Saw Yuzana Kyaing, Wunna Swe Design Considerations of PV Water Pumping and Rural Electricity System (2011) in Lower Myanmar. World Academy of Science, Engineering and Technology 75, 2011.
- [7] Rachid Chenni, Laid Zarour, Aissa Bouzid, Abdelhalim Borni Improvement of Synchronous and Asynchronous motor drive systems supplied by Photovoltaic Arrays with frequency control. Journal of Electrical Engineering, Vol. 59, No. 4, 2008, 169-177
- [8] Makbul Anwari M. Imran Hamid, and Taufik Power Quality Behavior of Single Phase Fed Adjustable Speed Drive Supplied from Grid of PV Generation .2nd IEEE International Conference on Power and Energy (PECon 08), December 1 – 3, Johor Bahru, Malaysia.
- [9] Muhammad H. Rashid. Power Electronics circuits, devices, and Applications. 3rd edition. Pearson Education, 2004.
- [10] Mehmet Akbaba Matching induction motors to PVG for maximum power transfer Science direct, Desalination 209 (2007) ;31–38.
- [11] B.L. Theraja, A.K. Theraja .A Textbook of Electrical Technology: Vol 2. AC and DC Machines, S.Chand & company Ltd, New Delhi.
- [12] A. Hamidata, B. Benyoucef Mathematic models of photovoltaic motor-pump systems .Science direct, Renewable Energy 33 (2008) 933–942.
- [13] K. Samidurai, K. Thanushkodi Digital simulation of Electronic transformer based single phase induction motor drive International journal of computer and network security, Vol.2 No.1 Jan. 2010