

# Power Quality Improvement by MC-UPQC Using Intelligence Techniques

**B.Rajani**

*Research Scholar, S.V.University.College of Engineering,  
Dept.of Electrical Engg, Tirupathi, A.P, INDIA,  
Email:lseepana\_\_2003@yahoo.co.in*

**Dr.P.Sangameswara Raju**

*Professor, S.V. University college of Engineering,  
Dept.of Electrical Engg Tirupathi, Andhra Pradesh, INDIA  
Email:Raju\_ps\_2000@yahoo.com*

## Abstract

Power quality (PQ) is a key technique for successful operation of equipments, industry and electric consumers and needs to supply good quality and uninterrupted power supply. The power supply problem is becoming copious concern in today's world since late 1980s. The power quality [3] has become one of the most abundant buzzwords in the power industry. Power quality is the quality of the electrical power supplied to electrical equipment. The increasing application of power operating device can cause PQ disturbances. Avoiding the PQ disturbance and enhancing the PQ are the difficult tasks. More power electronics devices are used to overcome the PQ disturbances.

Multi converter-Unified power quality conditioner (MC-UPQC) is one of the new power electronics devices that are used for enhancing the PQ. This paper presents a new unified power-quality conditioning system (MC-UPQC), capable of simultaneous compensation for voltage and current in multibus/multifeeder systems. In this configuration, one shunt voltage source converter (shunt VSC) and two or more series VSCs exist. The system can be applied to adjacent feeders to compensate for supply-voltage and load current imperfections on the main feeder and full compensation of supply voltage imperfections on the other feeders. In the proposed configuration, all converters are connected back to back on the dc side and share a common dc-link capacitor. sharing with one DC link capacitor. The discharging time of DC link capacitor is very high, and so it is the main problem in MC-UPQC device. To eliminate this problem, an enhanced based MC-UPQC is proposed in this paper. Initially, the error voltage and change of error voltage of a nonlinear load is determined. In order to regulate the dc-link capacitor voltage, conventionally, a proportional controller (PI) is used to maintain the dc-link voltage at the reference value. The transient response of the PI dc-link voltage controller is slow. So, a fast acting dc-link voltage controller is used by using Neuro-fuzzy logic controller(NFC) instead of the PI controller the transient response is improved. The DC capacitor charging output voltage is increased and the response is fast when compared with PI by using the NFC controller The non-linear load current is distorted and is compensated efficiently and the total harmonic distortion (THD) of the feeder current is minimized hence, the PQ of the system is enhanced.

**Keywords:** Power quality (PQ), MATLAB/SIMULATION Multi converter- unified power quality conditioner (MC-UPQC), voltage- source converter (VSC), Fuzzy, Neuro-Fuzzy controller(NFC).

## I. INTRODUCTION

Power quality issues are becoming more and more significant in these days because of the increasing number of Power electronic devices that behave as nonlinear loads. A wide diversity of solutions to power quality problems is available for both the distribution network operator and end user. The power processing at source, load and for Reactive and Harmonic Compensation by means of power electronic devices is becoming more prevalent due to the vast advantages. In addition, lightning strikes on transmission lines, switching of capacitor banks, and various network faults can also cause PQ problems, such as transients, voltage sag/swell, and interruption. On the other hand, an increase of sensitive critical loads involving digital electronics and complex process controllers requires a pure sinusoidal supply voltage for proper load operation [1].

In order to meet PQ standard limits, it may be necessary to include some sort of compensation. Modern solutions can be found in the form of active rectification on a active filtering [2]. A shunt active power filter is suitable for the suppression of negative load influence on the supply network, but if there are supply voltage imperfections, a series active power filter may be needed to provide full compensation [3].

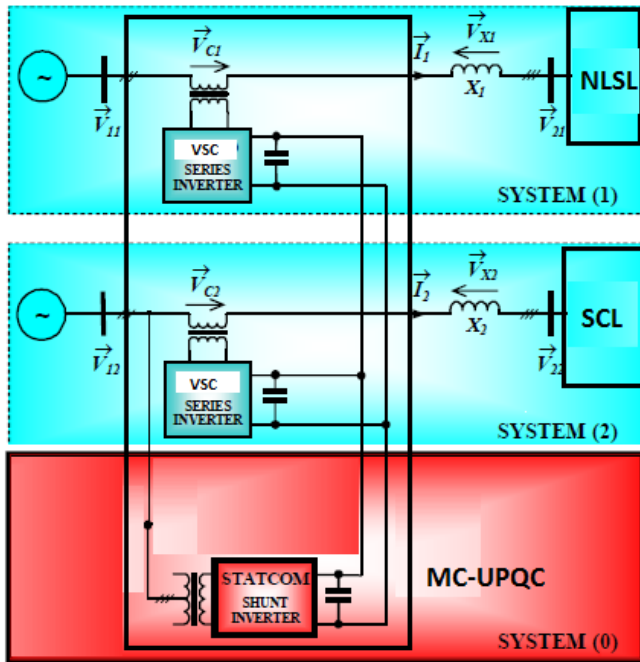

Fig.1. Block diagram of MC\_UPQC with STATCOM

In this paper, a new configuration of a UPQC called the multi converter unified power quality conditioner (MC\_UPQC) is presented. The system is extended by adding a series-VSC in an adjacent feeder. The proposed topology can be used for Simultaneous compensation of voltage and current imperfections both feeders by sharing power compensation capabilities between two adjacent feeders which are not connected. The system is also capable of compensating for interruptions without the need for a battery storage system and consequently without storage capacity limitations. The performance of the MC-UPQC as well as the adopted control algorithm is illustrated by simulation. The present work study the compensation principle and different controllers used here are based on PI, fuzzy, neuro-fuzzy Controllers of the MC-UPQC in detail. The results obtained in MATLAB/Simulink MC-UPQC on a two-bus/two-feeder system show the effectiveness of the proposed configuration.

## II. PROPOSED MC-UPQC SYSTEM

### A. Circuit configuration

The single-line diagram of a distribution system with an MC-UPQC is as shown in Fig.1. In this figure two feeders connected to two different substations supply the loads L1 and L2. With STATCOM. The MC-UPQC is connected to two buses BUS1 and BUS2 with voltages of  $u_{t1}$  and  $u_{t2}$ , respectively. The shunt part of the MC-UPQC is also connected to load L1 with a current of  $i_{l1}$ . Supply voltages are denoted by  $u_{s1}$  and  $u_{s2}$  while load voltages are denoted by  $u_{l1}$  and  $u_{l2}$ . Finally, feeder currents are denoted by  $i_{s1}$  and  $i_{s2}$  and load currents are  $i_{l1}$  and  $i_{l2}$ .

Bus voltages  $u_{t1}$  and  $u_{t2}$  are distorted and may be subjected to sag/swell. The load L1 is a nonlinear/sensitive load which

needs a pure sinusoidal voltage for proper operation while its current is non sinusoidal and contains harmonics. The load L2 is a sensitive/critical load which needs a purely sinusoidal voltage and must be fully protected against distortion, sag/swell, and interruption. These types of loads primarily include production industries and critical service providers, such as medical centers, airports, or broadcasting centers where voltage interruption can result in service economical losses or human damages.

### B. MC-UPQC Structure

The internal structure of the MC-UPQC is shown in Fig. 2.

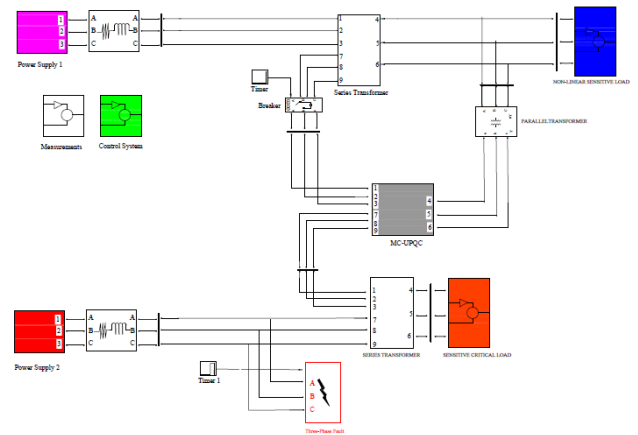

Fig.2 Typical Sim-link Block diagram MC-UPQC used in distribution system

It consists of three VSCs (VSC1, VSC2, and VSC3) which are connected back to back through a common dc-link capacitor. In the proposed configuration, VSC1 is connected in series with BUS1 and VSC2 is connected in parallel with load L1 at the end of Feeder1. VSC3 is connected in series with BUS2 at the Feeder2 end. Each of the three VSCs in Fig. 2 is realized by a three-phase converter with a commutation reactor and high-pass output filter as shown in Fig. 3. The commutation reactor ( $L_f$ ) and high-pass output filter ( $R_f, C_f$ ) are connected to prevent the flow of switching harmonics into the power supply, as shown in

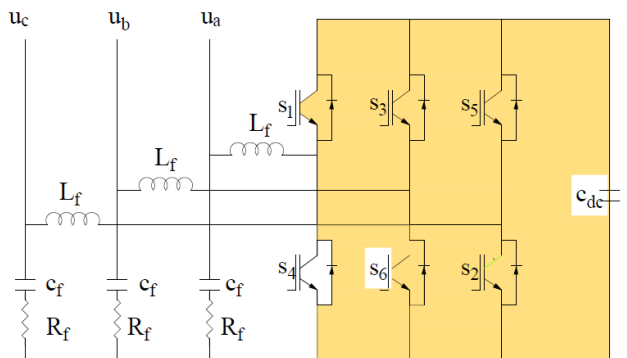

Fig.3 Schematic structure of a VSC

Fig. 2, all converters are supplied from a common dc-link capacitor and connected to the distribution system through transformer. Secondary (Distribution) sides of the series-connected transformers are directly connected in series with BUS1 and BUS2, and the secondary (distribution) side of the shunt-connected transformer is connected in parallel with load L1. The aims of the MC-UPQC shown in Fig. 2 are:

- 1) To regulate the load voltage ( $u_{l1}$ ) against sag/swell and disturbances in the system to protect the nonlinear/sensitive load L1;
- 2) To regulate the load voltage ( $u_{l2}$ ) against sag/swell, interruption and disturbances in the system to protect the sensitive/critical load L2;
- 3) To compensate for the reactive and harmonic components of nonlinear load current ( $i_{l1}$ )

In order to achieve these goals, series VSCs (i.e., VSC1 and VSC3) operate as voltage controllers while the shunt VSC (i.e., VSC2) operates as a current controller.

**C. Control Strategy**

As shown in Fig. 2, the MC-UPQC consists of two series VSCs and one shunt VSC which are controlled independently. The switching control strategy for series VSCs and the shunt VSC are selected to be sinusoidal Pulse width-modulation (SPWM) voltage control and hysteresis current control, respectively. Details of the control algorithm, which are based on the  $d-q$  method [12], will be discussed later.

**Shunt-VSC: functions of the shunt-VSC are:**

- 1) To compensate for the reactive component of the load L1 current;
- 2) To compensate for the harmonic components of the load current;
- 3) To regulate the voltage of the common dc-link capacitor.

The measured load current ( $i_{l,abc}$ ) is transformed into the synchronous  $dq0$  reference frame by using

$$i_{l,dq0} = T_{abc}^{dq0} i_{l,abc} \quad (1)$$

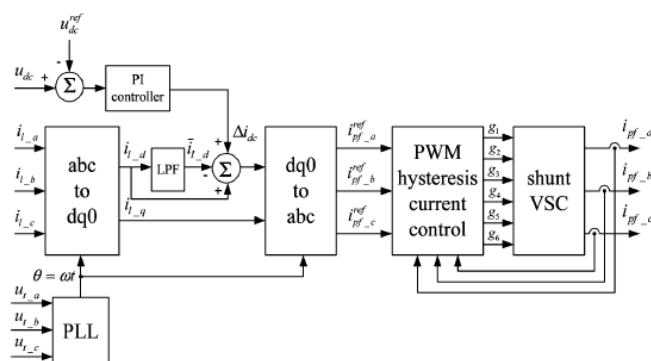

**Fig. 4 shows the control block diagram for the shunt VSC.**

where the transformation matrix is shown in (2).

$$T_{abc}^{dq0} = \frac{2}{3} \begin{bmatrix} \cos(\omega t) & \cos(\omega t - 120^\circ) & \cos(\omega t + 120^\circ) \\ -\sin(\omega t) & -\sin(\omega t - 120^\circ) & -\sin(\omega t + 120^\circ) \\ \frac{1}{2} & \frac{1}{2} & \frac{1}{2} \end{bmatrix} \quad (2)$$

By this transformation, the fundamental positive-sequence component, which is transformed into dc quantities in the  $d$  and  $q$  axes, can be easily extracted by low-pass filters (LPFs). Also, all harmonic components are transformed into ac quantities with a fundamental frequency shift

$$i_{l,d} = \bar{i}_{l,d} + \hat{i}_{l,d} \quad (3)$$

$$i_{l,q} = \bar{i}_{l,q} + \hat{i}_{l,q} \quad (4)$$

Where  $i_{l,d}$ ,  $i_{l,q}$  are  $d-q$  components of load current,  $\bar{i}_{l,d}$ ,  $\bar{i}_{l,q}$  are dc components, and  $\hat{i}_{l,d}$ ,  $\hat{i}_{l,q}$  are the ac components of  $i_{l,d}$  and  $i_{l,q}$ .

If  $i_s$  is the feeder current and  $i_{pf}$  is the shunt VSC current and knowing  $i_s = i_l - i_{pf}$ , then  $d-q$  components of the shunt VSC reference current are defined as follows:

$$i_{pf,d}^{ref} = \bar{i}_{l,d} \quad (5)$$

$$i_{pf,q}^{ref} = i_{l,q} \quad (6)$$

Consequently, the  $d-q$  components of the feeder current are

$$i_{s,d} = \bar{i}_{l,d} \quad (7)$$

$$i_{s,q} = 0 \quad (8)$$

This means that there are no harmonic and reactive components in the feeder current. Switching losses cause the dc-link capacitor voltage to decrease. Other

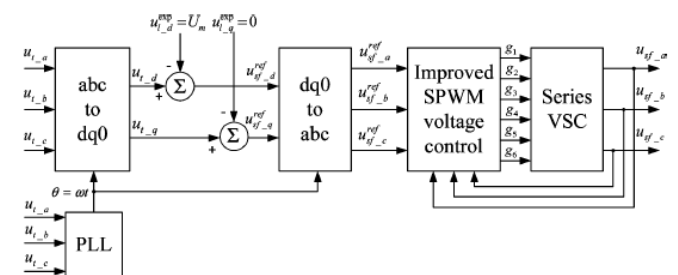

**Fig.5. Control block diagram of the series VSC**

Disturbances, such as the sudden variation of the load, can also affect the dc link. In order to regulate the dc-link capacitor voltage, a proportional-integral (PI) controller is used as shown in Fig. 4. The input of the PI controller is the error between the actual capacitor voltage ( $u_{dc}$ ) and its reference value ( $u_{dc}^{ref}$ ). The output of the PI controller (i.e.,

$\Delta i_{dc}$  is added to the  $d$  component of the shunt-VSC reference current to form a new reference current as follows:

$$\begin{cases} i_{pf,d}^{ref} = \tilde{i}l_d + \Delta i_{dc} \\ i_{pf,q}^{ref} = i_{l,q} \end{cases} \quad (9)$$

As shown in Fig. 4, the reference current in(9) is then transformed back into the  $abc$  reference frame. By using PWM hysteresis current control, the output-compensating currents in each phase are obtained

$$i_{pf,abc}^{ref} = T_{dq0}^{abc} i_{pf,dq0}^{ref}; (T_{dq0}^{abc} = T_{abc}^{dq0-1}) \quad (10)$$

**Series-VSC:** Functions of the series VSCs in each feeder are:

- 1) To mitigate voltage sag and swell;
- 2) To compensate for voltage distortion, such as harmonics;
- 3) To compensate for interruption (in Feeder2 only).

The control block diagram of each series VSC is shown in Fig. 5. The bus voltage ( $u_{t,abc}$ ) is detected and then transformed into the synchronous  $dq0$  reference and then transformed into the synchronous  $dq0$  reference frame using

$$u_{t,dq0} = T_{abc}^{dq0} u_{t,abc} = u_{t1p} + u_{t1n} + u_{t10} + u_{th} \quad (11)$$

Where

$$\begin{cases} u_{t1p} = [u_{t1p,d} \ u_{t1p,q} \ 0]^T \\ u_{t1n} = [u_{t1n,d} \ u_{t1n,q} \ 0]^T \\ u_{t10} = [0 \ 0 \ u_{00}]^T \\ u_{th} = [u_{th,d} \ u_{th,q} \ u_{th,0}]^T \end{cases} \quad (12)$$

$u_{t1p}$ ,  $u_{t1n}$  and  $u_{t10}$  are fundamental frequency positive-, negative-, and zero-sequence components, respectively, and  $u_{th}$  is the harmonic component of the bus voltage.

According to control objectives of the MC-UPQC, the load voltage should be kept sinusoidal with a constant amplitude even if the bus voltage is disturbed. Therefore, the expected load voltage in the synchronous  $dq0$  reference frame ( $u_{l,dq0}^{exp}$ ) only has one value

$$u_{l,dq0}^{exp} = T_{abc}^{dq0} u_{l,abc}^{exp} = \begin{bmatrix} u_m \\ 0 \\ 0 \end{bmatrix} \quad (13)$$

Where the load voltage in the  $abc$  reference frame ( $u_{l,abc}^{exp}$ ) is

$$u_{l,abc}^{exp} = \begin{bmatrix} u_m \cos(\omega t) \\ u_m \cos(\omega t - 120^\circ) \\ u_m \cos(\omega t + 120^\circ) \end{bmatrix} \quad (14)$$

The compensating reference voltage in the synchronous  $dq0$  reference frame ( $u_{sf,dq0}^{ref}$ ) is defined as

$$u_{sf,dq0}^{ref} = u_{t,dq0} - u_{l,dq0}^{exp} \quad (15)$$

This means  $u_{t1p,d}$  in (12) should be maintained at  $U_m$  while all other unwanted components must be eliminated. The compensating reference voltages in (15) are then transformed back into the  $abc$  reference frame.

By using an improved SPWM voltage control technique (since PWM control with minor loop feedback) [8], the output compensation voltage of the series VSC can be obtained.

### III. POWER-RATING ANALYSIS OF THE MC-UPQC

The power rating of the MC-UPQC is an important factor in terms of cost. Before calculation of the power rating of each VSC in the MC-UPQC structure, two models of a UPQC are analyzed and the best model which requires the minimum power rating is considered. All voltage and current phasors used in this section are phase quantities at the fundamental frequency.

There are two models for a UPQC-quadrature compensate (UPQC-Q) and inphase compensation (UPQC-P). In the quadrature compensation scheme, the injected voltage by the series-VSC maintains a quadrature advance relationship with the supply current so that no real power is consumed by the series VSC at steady state. This is a significant advantage when UPQC mitigates sag condition. The series VSC also shares the volt-ampere reactive (VAR) of the load with the shunt-VSC, reducing the power rating of the shunt-VSC.

Fig. 6 shows the phasor diagram of the scheme under a typical load power factor condition with and without a voltage sag. When the bus voltage is at the desired value ( $U_t = U_r = U_0$ ), the series-injected voltage ( $U_{sf}$ ) is zero [Fig. 6(a)]. The shunt VSC injects the reactive component of the load current  $I_c$ , resulting in unity input-power factor. Furthermore, the shunt VSC compensates for not only the reactive component, but also the harmonic components of the load current. For sag compensation in this model, the quadrature series voltage injection is needed as shown in Fig. 6(b). The shunt VSC injects  $I_c$  in such a way that the active power requirement of the load is only drawn from the utility which results in a unity input-power factor.

In an inphase compensation scheme, the injected voltage is inphase with the supply voltage when the supply is balanced. By virtue of inphase injection, series VSC will mitigate the voltage sag condition by minimum injected voltage. The phasor diagram of Fig. 7 explains the operation of this scheme in case of a voltage sag.

A comparison between inphase (UPQC-P) and quadrature (UPQC-Q) models is made for different sag conditions and load power factors in [13]. It is shown that the power rating of the shunt-VSC in the UPQC-Q model is lower than that of UPQC-P, and the power rating of the series-VSC in the UPQC-P model is lower than that of the UPQC-Q for a power factor of less than or equal to 0.9. Also, it is shown that the total power rating of UPQC-Q is lower than that of UPQC-P where the VAR demand of the load is high.

As discussed in Section II, the power needed for interruption compensation in Feeder2 must be supplied through the shunt VSC in Feeder1 and the series VSC in Feeder2. This implies

that power ratings of these VSCs are greater than that of the series one in Feeder1. If quadrature compensation in Feeder1 and in phase compensation in Feeder2 are selected, then the power rating of the shunt VSC and the series VSC (in Feeder2) will be reduced. This is an important criterion for practical applications.

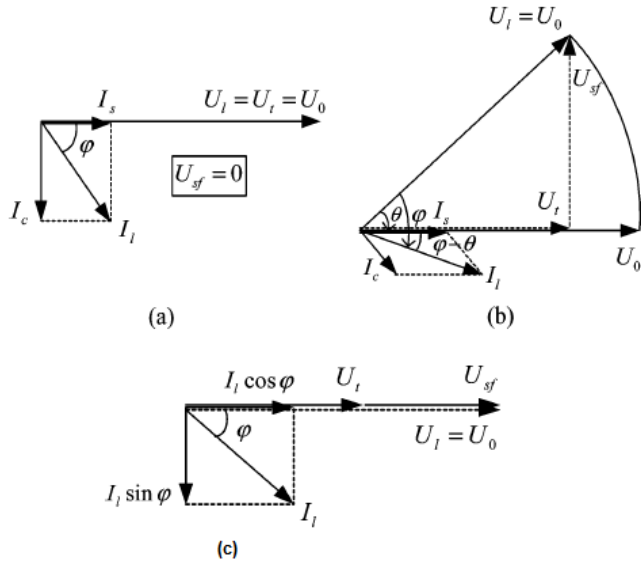

**Fig.6. phasor diagram of quadrature compensation. (a)Without voltage sag. (b)With voltage sag.(c) phasor diagram of in phase compensation(supply voltage sag)**

Based on the aforementioned discussion, the power-rating calculation for the MC-UPQC is carried out on the basis of the linear load at the fundamental frequency. The parameters in Fig. 6 are corrected by adding suffix “1,” indicating Feeder1, and the parameters in Fig. 7 are corrected by adding suffix “2,” indicating Feeder2. As shown in Fig. 6 and 7, load voltages in both feeders are kept constant at  $U_0$  regardless of bus voltages variation, and the load currents in both feeders are assumed to be constant at their rated values (i.e.,  $I_{01}$  and  $I_{02}$ , respectively)

$$U_{11} = U_{12} = U_0 \quad (16)$$

$$\begin{cases} I_{11} = I_{01} \\ U_{12} = I_{02} \end{cases} \quad (17)$$

The load power factors in Feeder1 and Feeder2 are assumed to be  $\cos \varphi_1$  and  $\cos \varphi_2$  and the per-unit sags, which must be compensated in Feeder1 and Feeder2, are supposed to be  $x_1$  and  $x_2$ , respectively.

If the MC-UPQC is lossless, the active power demand supplied by Feeder1 consists of two parts:

- 1) The active power demand of load in Feeder1;
- 2) The active power demand for sag and interruption compensation in Feeder2.

Thus, Feeder1 current ( $I_{s1}$ ) can be found as

$$U_{t1} I_{s1} = U_{11} I_{11} \cos \varphi_1 + U_{sf2} I_{12} \cos \varphi_2 \quad (18)$$

$$(1 - x_2) U_0 I_{s1} = U_0 I_{01} \cos \varphi_1 + x_2 U_0 I_{02} \cos \varphi_2 \quad (19)$$

$$(1 - x_1) I_{s1} = I_{01} \cos \varphi_1 + x_2 I_{02} \cos \varphi_2 \quad (20)$$

$$I_{s1} = \frac{I_{01} \cos \varphi_1}{(1 - x_1)} + \frac{x_2 I_{02} \cos \varphi_2}{(1 - x_1)} \quad (21)$$

From Fig. 6, the voltage injected by the series VSC in Feeder1 can be written as in (22) and, thus, the power rating of this converter ( $S_{VSC1}$ ) can be calculated as

$$U_{sf1} = U_{t1} \tan \theta = U_0 (1 - x_1) \tan \theta \quad (22)$$

$$\begin{aligned} S_{VSC1} &= 3 U_{sf1} I_{s1} = 3 U_0 (1 - x_1) \tan \theta \\ &\times \left( \frac{I_{01} \cos \varphi_1}{1 - x_1} + \frac{x_2 I_{02} \cos \varphi_2}{1 - x_1} \right) \end{aligned} \quad (23)$$

The shunt VSC current is divided into two parts.

- 1) The first part (i.e.,  $I_{c1}$ ) compensates for the reactive component (and harmonic components) of Feeder1 current and can be calculated from Fig. 6 as

$$\begin{aligned} I_{c1} &= \sqrt{I_{11}^2 + I_{s1}^2 - 2 I_{11} I_{s1} \cos(\varphi_1 - \theta)} \\ &= \sqrt{I_{01}^2 + I_{s1}^2 - 2 I_{01} I_{s1} \cos(\varphi_1 - \theta)} \end{aligned} \quad (24)$$

Where  $I_{s1}$  is calculated in (21). This part of the shunt VSC current only exchanges reactive power (Q) with the system.

- 2) The second part provides the real power (P), which is needed for a sag or interruption compensation in Feeder2. Therefore, the power rating of the shunt VSC can be calculated as

$$\begin{aligned} S_{VSC2} &= 3 U_{11} I_{pf} = 3 \sqrt{Q^2 + P^2} \\ &= 3 \sqrt{(U_{11} I_{c1})^2 + (U_{sf2} I_{12} \cos \varphi_2)^2} \\ &= 3 U_0 \sqrt{I_{c1}^2 + (x_2 I_{02} \cos \varphi_2)^2} \end{aligned} \quad (25)$$

where  $I_{c1}$  is calculated in (24).

Finally, the power rating of the series-VSC in Feeder2 can be calculated by (26). For the worst-case scenario (i.e., interruption compensation), one must consider  $x_2 = 1$ . Therefore

$$S_{VSC3} = 3 U_{sf2} I_{12} = 3 x_2 U_0 I_{02} \quad (26)$$

**IV. SIMULATION RESULTS**

The proposed MC-UPQC and its Neuro-fuzzy control schemes have been tested through extensive case study simulations using MATLAB/SIMULINK. In this section, simulation results are presented, and the performance of the proposed MC-UPQC system is shown. Simulation is carried out in this case study under distorted conditions of current and supply voltages in feeder1. The distorted non-linear load currents are compensated very well. The input voltage harmonics and current harmonics caused by non-linear load, effectiveness of MCUPQC with different controllers is evident from Fig.10, Fig 11 & Fig.12. As the source current becomes sinusoidal and balanced from 0.5 s. The scheme is first simulated without MC-UPQC to find out the THD of the supply voltage and current. Then, it is simulated with MC-UPQC to observe the difference in THD of supply current and voltages for the proposed model MC-UPQC.

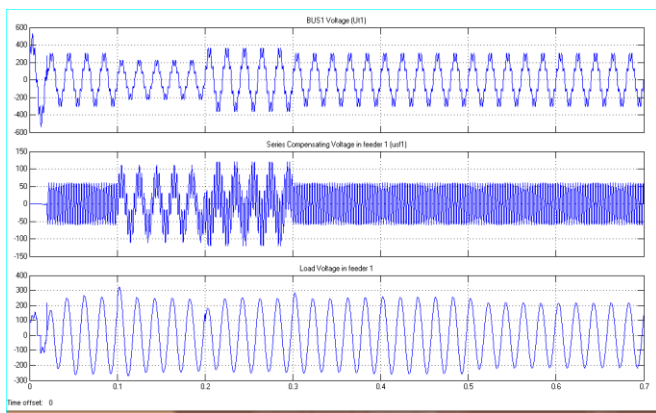

**Fig.7 simulated results for bus1 voltage, its series compensating voltage and load voltage in Feeder 1**

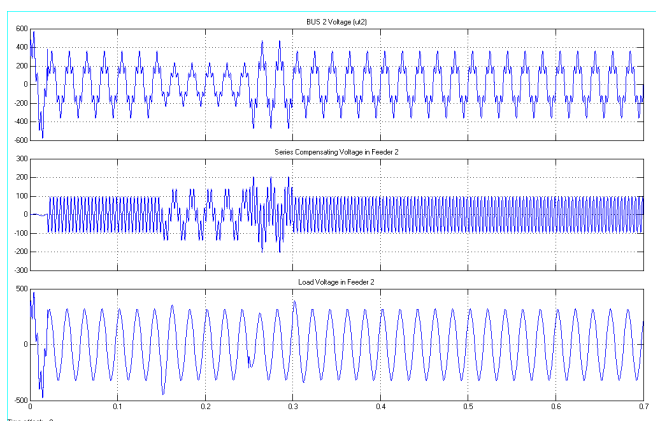

**Fig. 8 Simulated results for BUS2 voltage, series compensating voltage in feeder 2, and its load voltage.**

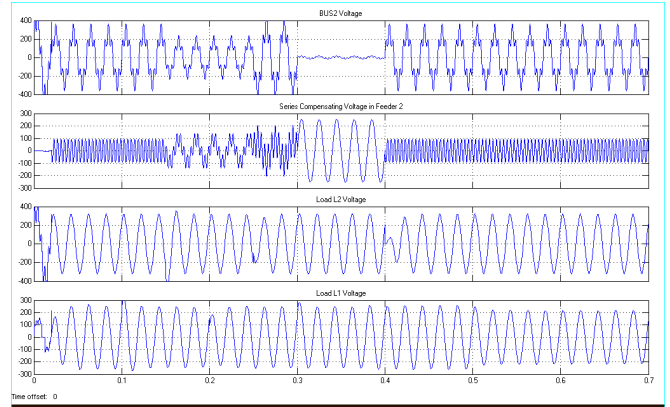

**Fig. 9 simulated results for BUS2 Voltage under fault condition, its Series compensation Voltage in feeder 2.**

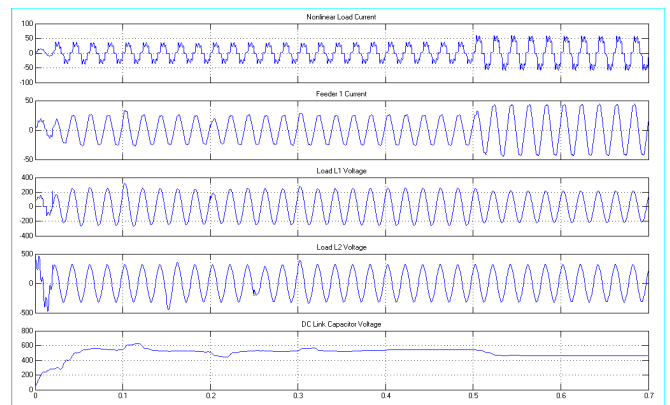

**Fig. 10 Simulation results: Nonlinear load current, Feeder1 current, load L1, L2 voltages and DC-link capacitor voltage for load change with PI controller.**

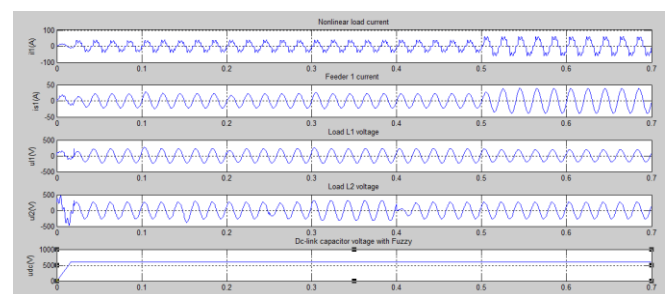

**Fig. 11 Simulation results for: Nonlinear load current, Feeder1 current, load L1, L2 voltages and DC-link capacitor voltage when load change with FUZZY controller.**

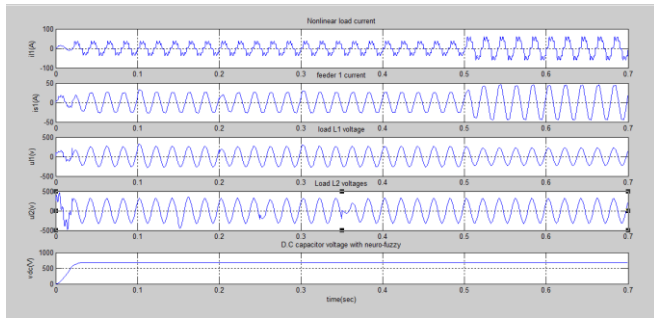

**Fig.12.Simulation results: Nonlinear load current, Feeder1 current, load L1, L2 voltage and DC-link capacitor voltage for load change with NEURO-FUZZY controller.**

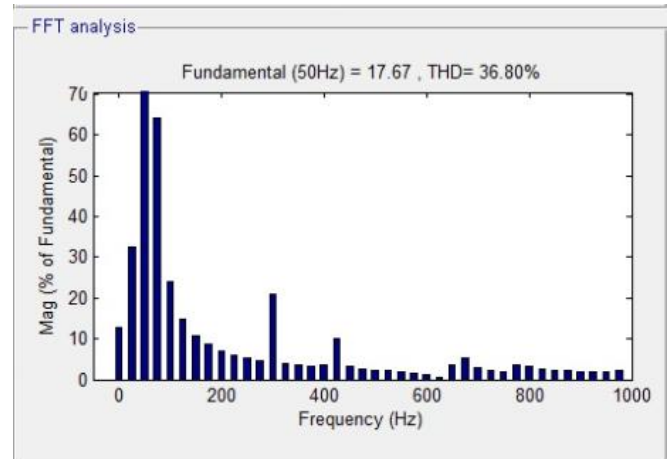

**Fig. 13 THD for utility side voltage without MC-UPQC**

Let us consider that the power system in Fig. 2 consists of two three-phase three-wire 380(v) (rms, L-L), 50-Hz utilities. The BUS1 voltage ( $u_{t1}$ ) contains the seventh-order harmonic with a value of 22%, and the BUS2 voltage ( $u_{t2}$ ) contains the fifth-order harmonic with a value of 35%. The BUS1 voltage contains 25% sag between  $0.1 s < t < 0.2 s$  and 20% swell between  $0.2 s < t < 0.3 s$ . The BUS2 voltage contains 35% sag between  $0.15 s < t < 0.25 s$  and 30% swell between  $0.25 s < t < 0.3 s$ . The nonlinear/sensitive load L1 is a three-phase rectifier load which supplies an RC load of  $10\Omega$  and  $30 \mu F$ . Finally, the critical load L2 contains a balance RL load of  $10 \Omega$  and  $100mH$ .

The MC-UPQC is switched on at  $t = 0.02 s$ . The BUS1 voltage, the corresponding compensation voltage injected by VSC1 and finally load L1 voltage are shown in Fig. 7. In all figures, only the phase *a* waveform is shown for simplicity.

Similarly, the BUS2 voltage, the corresponding compensation voltage injected by VSC3, and finally, the load L2 voltage are shown in Fig.8. As shown in these figures, distorted voltages of BUS1 and BUS2 are satisfactorily compensated for across the loads L1 and L2 with very good dynamic response.

The nonlinear load current, its corresponding compensation current injected by VSC2, compensated Feeder1 current, and, finally, the dc-link capacitor voltage are shown in Fig. 10. The distorted nonlinear load current is compensated very well, and the total harmonic distortion (THD) of the feeder current is reduced from 22% to less than 5%. Also, the dc voltage regulation loop has functioned properly under all the disturbances, such as sag/swell in both feeders One of the many solutions is the use of a combined system of shunt and Series converter like multi converter unified power quality conditioner (MC-UPQC).compensate the supply voltage and the load current or to mitigate any type of voltage and current fluctuations sag, swell and power factor correction in a power distribution network. The controllers used here are based on PI, Fuzzy and Neuro-Fuzzy controllers of the MC-UPQC in detail. The control strategies are modeled using MATLAB/SIMULINK.. The simulation results are listed in comparison of different controllers are shown in figures 10, 11and 12

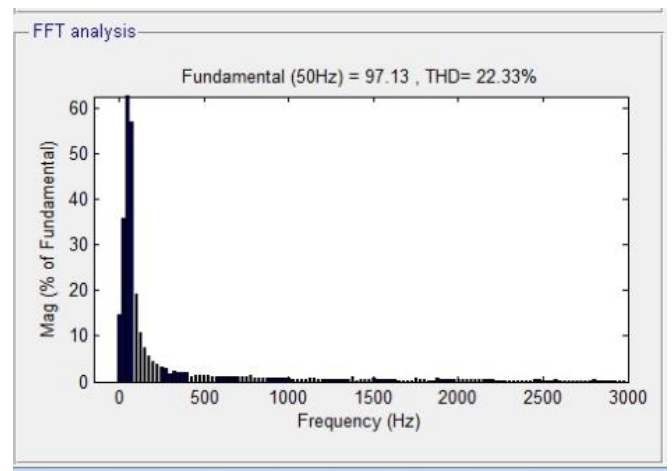

**Fig.14 THD for utility side current without MC-UPQC**

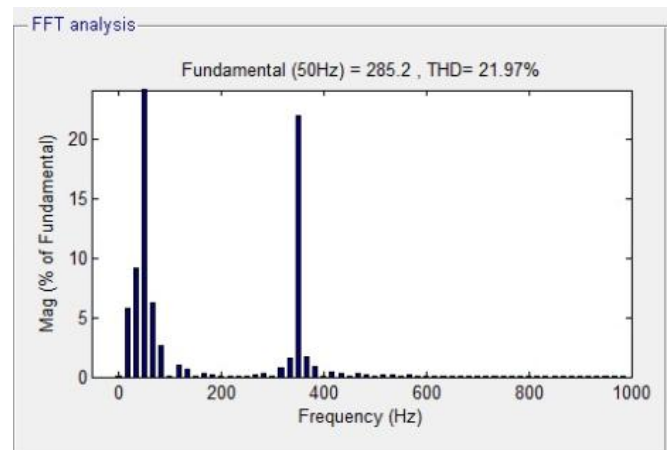

**Fig.15 THD for utility side voltage using PI controller with MC-UPQC (with d-q method).**

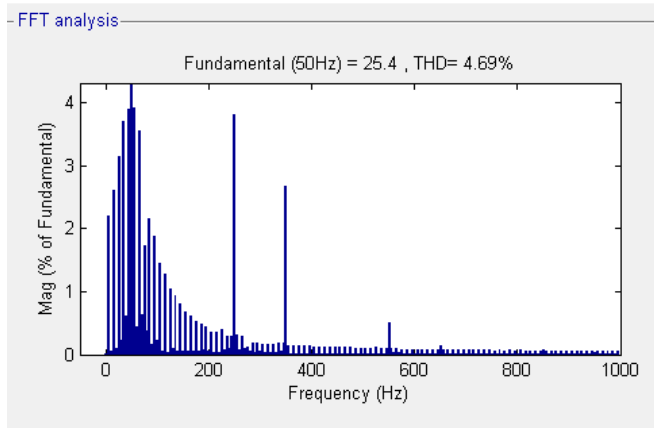

**Fig.16 THD for utility side current using PI controller with MC-UPQC (with d-q method)**

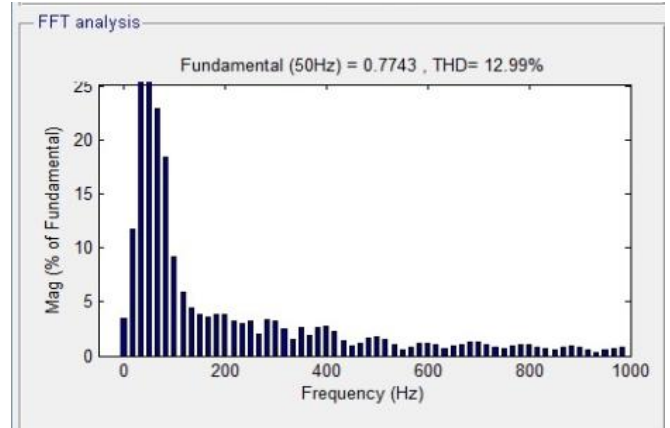

**Fig.19 THD for utility side voltage using NEURO-FUZZY controller with MC-UPQC (with d-q method)**

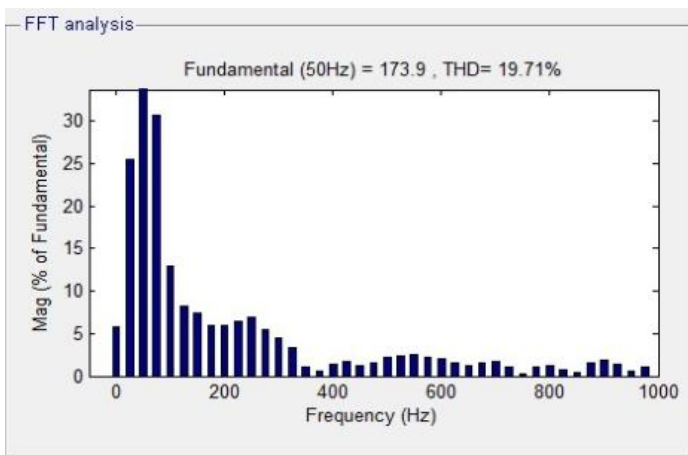

**Fig.17 THD for utility side voltage with FUZZY controller using MC-UPQC (with d-q method)**

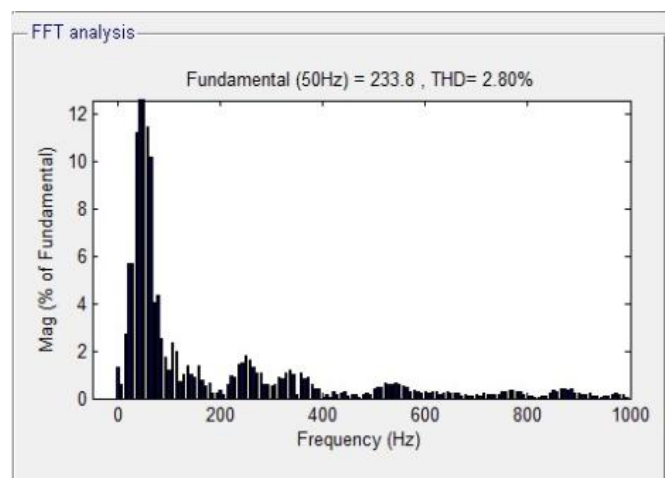

**Fig.20 THD for utility side current using NEURO-FUZZY controller with MC-UPQC (with d-q method).**

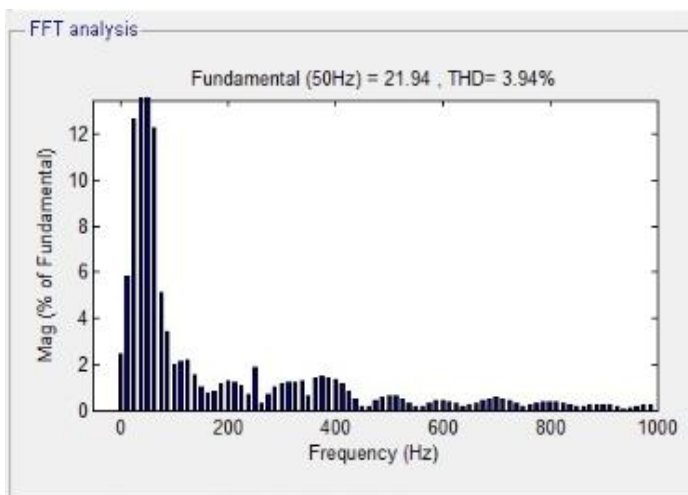

**Fig.18 THD for utility side current with FUZZY controller using MC-UPQC (with d-q method)**

**TABLE 1 COMPARISON TABLE FOR VOLTAGE AND CURRENT HARMONICS (THDS) OF MC- UPQC**

Fig. No.	Controller used	THD values %
13	Without MC-UPQC utility side voltage	36.805
14	Without MC-UPQC utility side current	22.33
15	MC-UPQC with PI controller utility side voltage	21.97
16	MC-UPQC with PI controller utility side current	4.69
17	MC-UPQC with FUZZY controller utility side voltage	19.71
18	MC-UPQC with FUZZY controller utility side current	3.94
19	MC-UPQC with NEURO-FUZZY controller utility side voltage	12.99
20	MC-UPQC with NEURO-FUZZY controller utility side current	2.80

## V. CONCLUSION

The present topology illustrates the operation and control of Multi Converter Unified Power Quality Conditioner (MC-UPQC). The system is extended by adding a series VSC in an adjacent feeder. A suitable mathematical have been described which establishes the fact that in both the cases the compensation is done but the response of NEURO-FUZZY controller is faster and the THD is minimum for both the voltage and current in sensitive/critical load. The device is connected between two or more feeders coming from different substations. A non-linear/sensitive load L-1 is supplied by Feeder-1 while a sensitive/critical load L-2 is supplied through Feeder-2. The performance of the MC-UPQC has been evaluated under various disturbance conditions such as voltage sag/swell in either feeder, fault and load change in one of the feeders. In case of voltage sag, the phase angle of the bus voltage in which the shunt VSC (VSC2) is connected plays an important role as it gives the measure of the real power required by the load. The MC-UPQC can mitigate voltage sag in Feeder-1 and in Feeder-2 for long duration.

## REFERENCES

- [1] Hamid Reza Mohammadi, Ali Yazdian Varjani, and Hossein Mokhtari, "Multiconverter Unified Power-Quality Conditioning System: MC- UPQC" IEEE RANSACKIONS ON POWER DELIVERY, VOL. 24, NO. 3, JULY 2009.
- [2] R.Rezaeipour and A.Kazemi, "Review of Novel control strategies for UPQC" Internal Journal of Electric and power Engineering 2(4) 241-247, 2008.
- [3] S. Ravi Kumar and S.Siva Nagaraju "Simulation of TATCOM and DVR in power systems" Vol. 2, No. 3, June 2007 ISSN 1819-6608 ARPJN Journal of Engineering and Applied Sciences.
- [4] M.V.Kasuni Perera "Control of a Dynamic Voltage Restorer to compensate single phase voltage sags" Master of Science Thesis, Stockholm, Sweden 2007.
- [5] M. Basu, S. P. Das, and G. K. Dubey, "Comparative evaluation of two models of UPQC for suitable interface to enhance power quality, " *Elect.Power Syst. Res.*, pp. 821–830, 2007.
- [6] A. K. Jindal, A. Ghosh, and A. Joshi, "Interline unified power quality conditioner, " *IEEE Trans. Power Del.*, vol. 22, no. 1, pp. 364–372, Jan. 2007.
- [7] B. Singh, K. Al-Haddad, and A. Chandra, "A review of active power filters for power quality improvement, " *IEEE Trans. Ind. Electron.*, vol. 45, no. 5, pp. 960–971, Oct. 1999.
- [8] C. A. Quinn and N.Mohan, "Active filtering of harmonic currents in three-phase, four-wire systems with three-phase and single-phase nonlinear loads, " in *Proc. 7th IEEE APEC*, 1992, pp. 829–836.
- [9] H. Akagi, Y. Kanazawa, and A. Nabae, "Instantaneous reactive power compensators comprising switching devices without energy storage components, " *IEEE Trans. Ind. Appl.*, vol. IA-20, no. 3, pp. 625–630, May/Jun. 1984.
- [10] Y. Komatsu and T. Kawabata, "A control method of active power filter in unsymmetrical and distorted voltage system, " in *Proc. Conf. IEEE Power Convers.*, 1997, vol. 1, pp. 161–168.
- [11] M. T. Haque, "Single-phase PQ theory, " in *Proc. 33rd IEEE PESC*, 2002, vol. 4, pp. 1815–1820.
- [12] J. M. Correa, S. Chakraborty, M. G. Simoes, and F. A. Farret, "A singlephase high frequency AC microgrid with an unified power quality conditioner, " in *Conf. Rec. 38th IEEE IAS Annu. Meeting*, 2003, vol. 2, pp. 956–962.
- [13] V. Khadkikar, A. Chandra, A. O. Barry, and T. D. Nguyen, "Application of UPQC to protect a sensitive load on a polluted distribution network, " in *Proc. IEEE PES General Meeting*, Montreal, QC, Canada, 2006, 6 pp.
- [14] V. Khadkikar, A. Chandra, A. O. Barry, and T. D. Nguyen, "Conceptual analysis of unified power quality conditioner (UPQC), " in *Proc. IEEE ISIE*, 2006, pp. 1088–1093.