

Study of the structural and acoustic properties of clothing materials for thermal protection of human

Cherunova I.V.

Institute of Service and Business (branch) Don State Technical University, 346500, 147 Shevchenko street, Shakhty

Kolesnik S.A.

Institute of Service and Business (branch) Don State Technical University, 346500, 147 Shevchenko street, Shakhty

Kurenova S.V.

Institute of Service and Business (branch) Don State Technical University, 346500, 147 Shevchenko street, Shakhty

Eremina Yu.V.

Institute of Service and Business (branch) Don State Technical University, 346500, 147 Shevchenko street, Shakhty

Merkulova A.V.

Institute of Service and Business (branch) Don State Technical University, 346500, 147 Shevchenko street, Shakhty

Cherunov P.V.

Institute of Service and Business (branch) Don State Technical University, 346500, 147 Shevchenko street, Shakhty

Abstract

The article is dedicated to the researches of the structure of special materials for uniform. It is done due to the necessity of achieving success in human protection against heat, fire, water and noise. The discovered correlations between composition and structure of textile materials and their combinations with additional enhanced layers and the physical properties of uniform allow to provide for a more effective personal protection. For evaluation of the effectiveness of such protection a method monitoring of human comfort is suggested.

Keywords: Textile materials, protective clothing, design, research methods, thermal properties, acoustic structure.

Introduction

Risks for the life and health of the person caused by overheating and overcooling remain to be one of the most dangerous groups. In conditions of both high heat and critical cold the own possibilities of thermal control of the person are extremely limited and aren't sufficient for his life. The new ecological threat for health of the population are long heat waves which resulted in the increased death and diseases of people in the countries of Europe and Russia [1]. On the other hand, the program of the development of the Arctic, puts the directions of health and life safety, working abilities of the person and the efficiency of work in extreme situations of critical cold into the group of special attention as there are the coldest climatic conditions of the planet which extremely

complicate the life of people in this territory [2]. Today it is possible to reduce the thermal instability of the person in high - and low-temperature zones (production work, rescue operations, etc.) by the use of bulky equipment with limited time of action. In the situations where the technical communications are absent or few, the direction for designing autonomous systems of the biothermal control (which don't depend on the central power supply) based on the use of renewable power sources working from own thermal bioresources of the person is very actual.

he heat effects on a person can have a critical level. Such risks are typical for professional activities of fire guides. During extinguishing fire the temperature can be 250 or 1000 degrees [3]. The clothes serve the main protective function for a person from heat effects. The protective clothes consist of special materials. They are characterized by porous structure. The porosity of materials allows creating an air layer inside the clothes. It is proved by modern research, based on acoustic methods application [4]. The air layer in clothes is determined by the fiber construction of materials and system of their weave. Different combinations of materials together with polymeric films allow creating not only a heat barrier for a person but also another kind of protection [5]. It's important to create additional protection from noise for a person in clothes at production site. Nowadays many enterprises work at high level of noise [6]. The noise produces unfavorable effect upon the person's health: not only upon the sense of hearing, but also upon the internal organs [7]. The part of dangerous soundwave, directed to a person, can be absorbed by the clothes. The materials have various structure and different

degrees of the noise absorption. This determines the safety of a person at production site.

When choosing the materials for protection from dangerous heat and noise it's important to know the main danger. If a person works with fire, then the most important will be the protection from fire. Such clothes require materials with a barrier to fire; they help to keep the clothes dry. There are many scientific works in different countries devoted to the research of modern materials for the clothes [8-10]. However, the question of the effective set creation, made of materials for a person's protection from dangerous temperature (cold, heat, fire) and noise simultaneously, hasn't been solved yet. New solutions require additional techniques of check. For this purpose it is necessary to create not only the set of materials but also to make clothes of them. So, the research of construction and the choice of exterior materials for protective clothes allow creating a barrier to fire and water. Further, the combination of material construction and composition enables to make protection from dangerous temperature and noise. The check of new solutions of protective clothes, made of special materials, requires the application of specific techniques and devices.

The main part of research

To identify the main parameters of materials to be studied a special logical system was developed (fig.1).

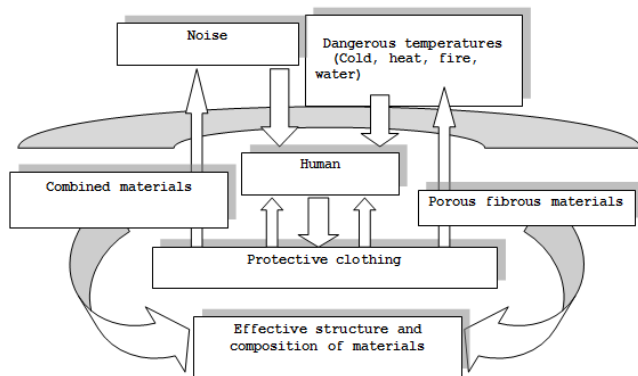

Fig. 1. Logical system to define the characteristics of protective materials

The diagrams show that the structure of materials at the base level determines the formation of their basic properties. When creating materials with the necessary properties the underlying polymers are mixed with other substances. Additional substances may have a new structure or do not change the basic structure of the polymer. For protection against external influences complex materials are applied. They consist of a base support fabrics and special coatings. The woven fabrics made of synthetic or artificial fibres, filament yarn and cotton are the base for such materials.

The threads of fabrics have a special interweaving system [11]. The properties of materials related to hygiene and technological processes depend on the structure of the weave of the fabric. The most dangerous environmental factor in the

system (fig.1) is fire. For study of materials structure we used the following materials protecting against fire: Rhemes FR 350 A, Greta M, FlameStat Cotton, Premier Comfort, Greta, Saviour, Nomex (Cevlar-1), Nomex Comfort (Cevlar-2), Indura Ultra Soft and Flameshield. The structure of each material consists of cotton, anti-static thread and special handling substances for protection against dirt.

Structural analysis using a microscope grade M 501 (1:40) according to the figure 2-11: a) the structure of the interweaving on the outer surface, b) structure of the interweaving on the inner surface.

Fabric "«Premier FR 350 A»" (density: 350 g/m²) (fig.2), made in Russia [12]. Interweaving of type "atlas". The material consists of 100% cotton and antistatic fiber "Bekite". For the fire protection the special treatment Pyrovatex® is used.

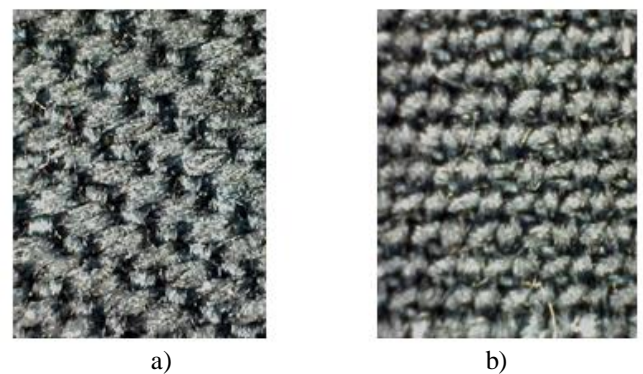

Fig. 2. Interweaving of Fabric «Premier FR 350 A»

Fabric "Greta-M" (density: 208 g/m²) (fig.3) made in Belarus [13]. Interweaving of type "Sarzh 2/1". The material consists of 53% cotton and 47% polyester

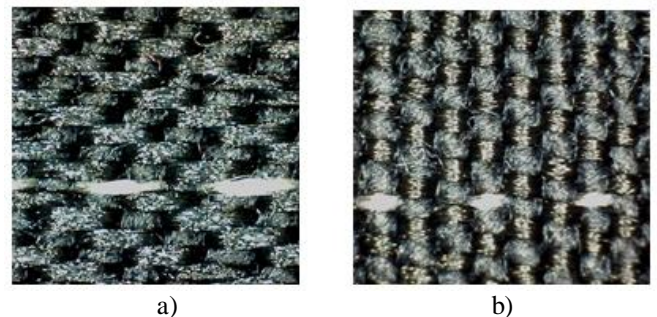

Fig. 3. Interweaving of Fabric «Greta-M»

Fabric "FlameStat Cotton" (density: 335 g/m²) (fig.4), made in United Kingdom [14]. Interweaving of type "Satin 4/1". The material consists of 100% cotton and antistatic fiber "Bekite". For the fire protection the special treatment Proban® is used.

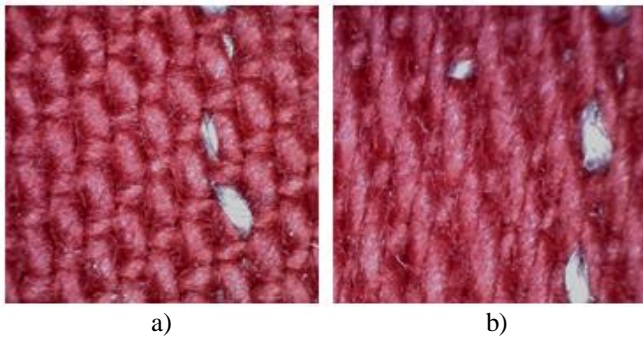

Fig. 4. Interweaving of Fabric «FlameStat Cotton»

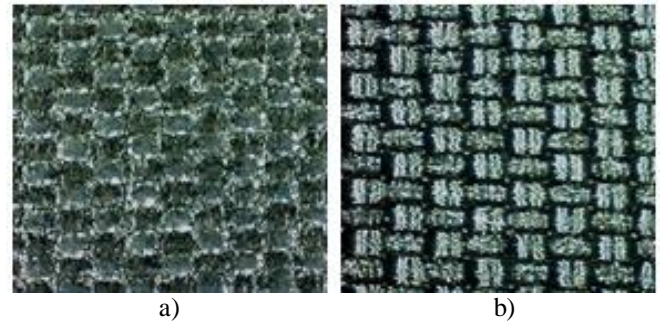

Fig. 7. Interweaving of Fabric Saviour

Fabric " Premier Comfort " (density: 225 g/m²) (fig.5), made in Russia [12]. Interweaving of type " Sarzha ". The material consists of 80% cotton and 20% polyester.

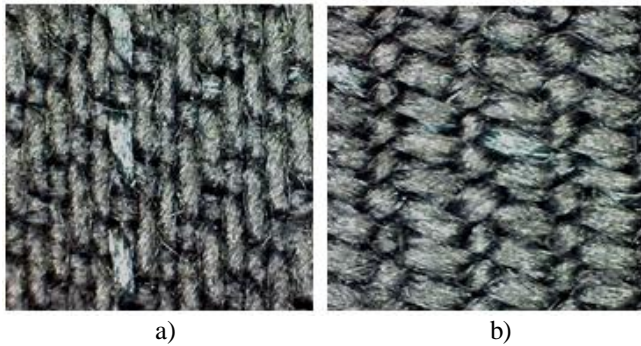

Fig. 5. Interweaving of Fabric « Premier Comfort»

Fabric " Greta " (density: 214 g/m²) (fig.6), made in Belarus [13]. Interweaving of type " Sarzha 2/1 ". The material consists of 53% cotton and 47% polyester.

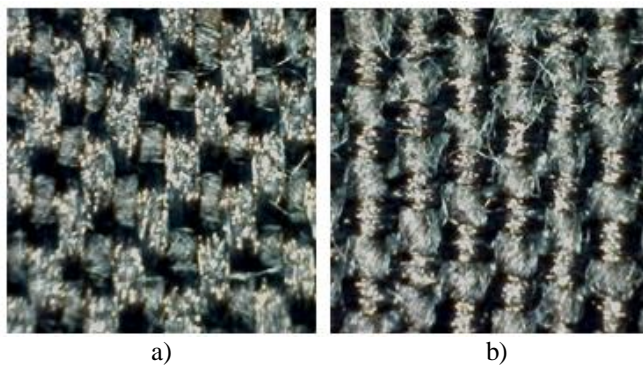

Fig. 6. Interweaving of Fabric «Greta»

Fabric " Savior " (density: 150 g/m²) (fig.7), made in Belgium [15]. Interweaving of type " Polotno ". The material consists of 100% polyefir.

Fabric " Nomex " (density: 230 g/m²) (fig.8), made in USA [16]. Interweaving of type "Sarzha". The material consists of 100% cotton. For the fire protection the special fiber "metaaramid" is used.

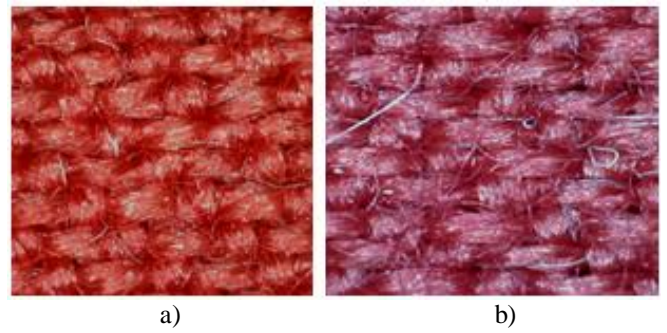

Fig. 8. Переплетение волокон в ткани Nomex

Fabric " Nomex Comfort " (density: 260 g/m²) (fig.9), made in USA [16]. Interweaving of type "Sarzha 2/1". The material consists of 100% cotton. For the fire protection the special fiber "metaaramid" end «paraaramid» is used.

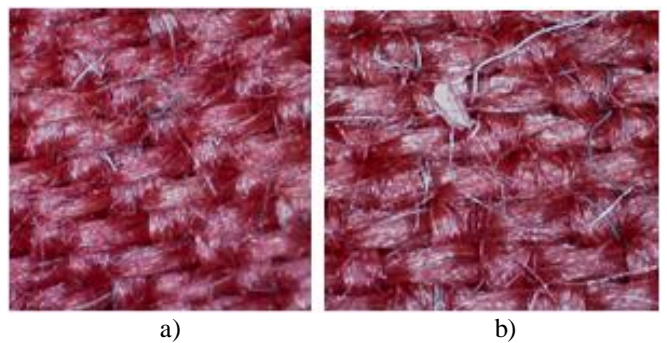

Fig. 9. Interweaving of Fabric Nomex Comfort

Fabric " Indura Ultra Soft " (density: 305 g/m²) (fig.10), made in USA [17]. Interweaving of type "Satin". The material consists of 88% cotton and 12% Nylon.

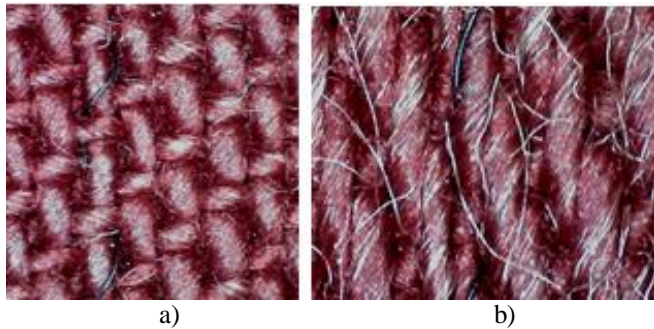

Fig. 10. Interweaving of Fabric Indura Ultra Soft

Fabric "Flameshield" (density: 380 g/m²) (fig.11), made in United Kingdom [14]. Interweaving of type "Satin". The material consists of 100% cotton.

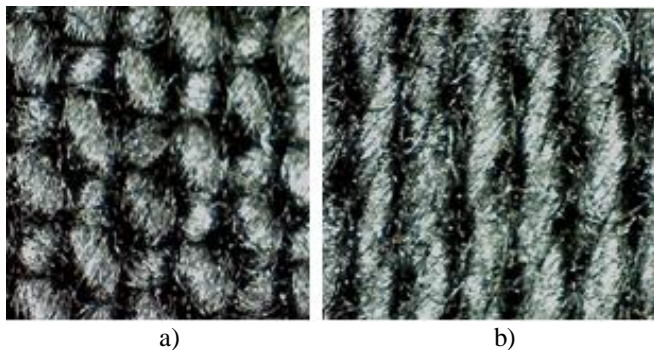

Fig. 11. Interweaving of Fabric Flameshield

Analysis of the structure of materials for fire protection showed that a large part of them is the intertwining of class "Diagonal": "Atlas" (Remig FR 350 A), "Sarzha" (Greta-M, Premier Comfort, Greta, Nomex, Nomex Comfort), "Satin" (FlameStat Cotton, Indura Ultra Soft, Flameshield). The class interweaving "canvas" (Saviour) is used rarely. Established interweaving classes affect such properties of materials as permeability and contact with water.

Determination of properties related to the contact with water was carried out in accordance with the GOST 29104.11-91 [18]. It is found that all samples of the selected materials do not absorb water. The air permeability test was performed in accordance with the GOST 12088-77 [19]. The device ATL-2 shown in Figure 12 was used for the study of air permeability. Minimum and maximum values of all measurements of every sample are used as preliminary estimations. The results are shown in tab. 1.

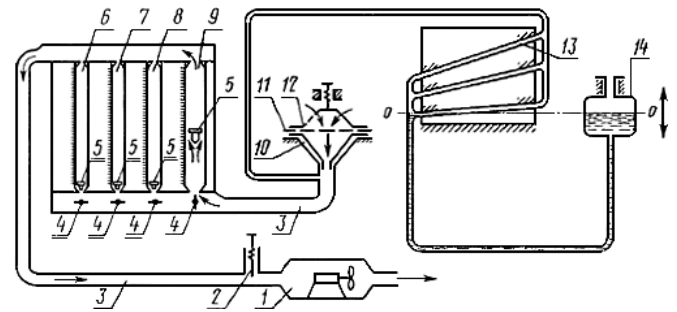

Fig.12. Device ATL-2 [19] for determination of the air permeability: 1 - the electrical fan; 2 - a valve-needle; 3 - connecting pipes; 4 - arm rotameters; 5 - rotameter floats; 6, 7, 8, 9 - rotameters; 10 - table; 11 - tested fabric; 12 - clamp ring; 13 - micro manometer; 14 - vessel with distilled water

Tab. 1. Experimental assessment of heat resistant materials

Material name	The surface's densit, g/m ²	Wettability,	Capillarity, mm	Air permeability dm ³ /(m ² ·s)	
				max	min
Premier FR 350A Apr 10202 a-M	340	Not wetted	Vertical -0 Horizontal-0	118, 3	72
Greta-M	208	Not wetted	Vertical -0 Horizontal-0	113, 2	113, 2
FlameStat Cotton	335	Not wetted	Vertical -0 Horizontal-0	113, 2	113, 2
Premier Comfort	255	Not wetted	Vertical -0 Horizontal-0	128, 6	123, 5
Greta	214	Not wetted	Vertical -0 Horizontal-0	133, 7	133, 7
Saviour	150	Not wetted	Vertical -0 Horizontal-0	10, 3	10, 3
Nomex Comfort	260	Not wetted	Vertical -0 Horizontal-0	185, 2	185, 2
Nomex	230	Not wetted	Vertical -0 Horizontal-0	195, 5	195, 5
Indura Ultra Soft	305	Not wetted	Vertical -0 Horizontal-0	30, 8	30, 8
Flameshield	380	Not wetted	Vertical -0 Horizontal-0	72, 0	72, 0

All materials with a high degree of protection from fire have also a protection from water. The analysis of results of study for the structure and properties of materials contacting with water and air showed that the highest air permeability has the fabric Nomex – 195, 5 dm³/(m²·s), and the lowest one has Saviour – 10, 3 dm³/(m²·s). The total interval of air permeability performance ranges from 72 dm³/(m²·s) to 190 dm³/(m²·s). Therefore, the most efficient material for the design of the outer layer of protective warm is Saviour. It has a small weight and the lowest air permeability. This will provide the person wearing in such clothes a good protection

from wind and cold. This material meets the requirements EN368, EN531, EN533, EN471, EN343 [20].

Within the next step we performed study of the inner layer of protective clothing. According to Fig. 1 the inner layer should protect human body from heat flux and noise.

Basic quantity for characterizing the acoustic properties of materials is the sound absorption coefficient. It is the ratio of absorbed energy to the energy impact on the surface of the material [4, 21]. However, the parameter is not considered for textiles for clothes. Textile materials do not have the characteristics of the sound absorption coefficient. This is important for the design of effective protective clothing.

The study was performed with 120 samples of materials for clothing. For part of the materials we obtained technical characteristics, which do not allow to apply them in a complex set of materials for noise protection because of their large weight and thickness [22].

To increase the level of protection from noise, we have proposed a comprehensive solution. According to this solution an efficient inner material with proper acoustic properties is introduced. Also the geometric for of the outer material should be changed.

Material surface geometry variation diagram is presented at Fig. 13.

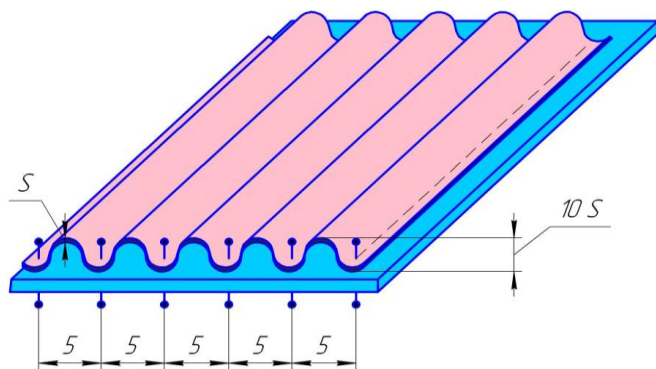

Fig. 13. Material surface geometry variation diagram (Typ "Geom")

The design of protective suit does not allow using of such fabric for all structural parts.

Materials with new surface geometry may be used at areas with particular noise hazard: knees, elbows, spine rest [23].

Materials were subjected to experimental tests. This work is dedicated to creation of special equipment for research of acoustic properties of clothing materials [22]. This device allows measuring acoustic performance and defining absorption factor for acoustic vibrations. The measurements are considered in essential parts of acoustic spectrum.

High noise protection at 100 and 1000 Hz is ensured by 100% cotton materials. Var. «dzhins», «stockinet», «Aramid Fabric (Kevlar)». They are recommended for clothing manufacturing technology.

Experimental researches of sets of materials were performed to define the influence of components, structure and new surface geometry of fabrics on clothing acoustic properties:

№1 - «100 % cotton. Var. «dzhins» + stockinet»;

№2 - «100 % cotton. Var. «dzhins» ("Geom") + stockinet»;

№3 - «Aramid Fabric (Kevlar) + stockinet»;

№4 - «Aramid Fabric (Kevlar), ("Geom") + stockinet»;

№5 - «Kevlar (2 layers) + stockinet»;

№6 - «Kevlar (2 layers), ("Geom") + stockinet».

Experimental research results are presented at Fig. 14.

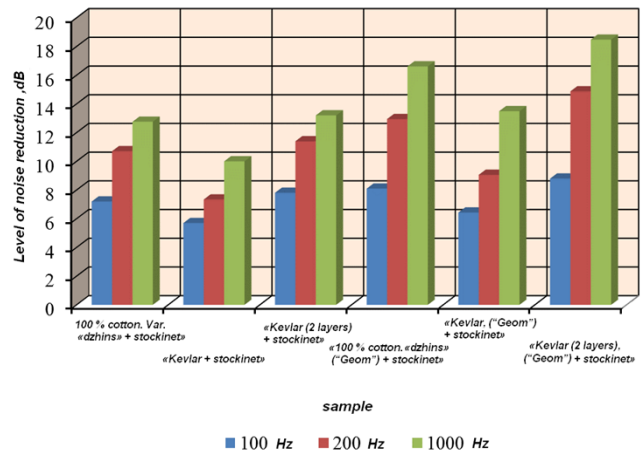

Fig. 14. Graph of materials components, structure and surface geometry versus acoustic properties of clothing.

Fig. 14 shows that variation of "100% cotton" material surface geometry in set No. 2 results in 1.12 times increase of noise absorption at 100 Hz, 1.2 times at 200 Hz and 1.3 times at 1000 Hz. When surface geometry is modified for Cevlar material in set No. 3, noise absorption increases 1.13 times at 100 Hz, 1.23 times at 200 Hz and 1.35 times at 1000 Hz. When surface geometry is modified for two layers of Cevlar material in set No. 5, noise absorption increases 1.13 times at 100 Hz, 1.3 times at 200 Hz and 1.4 times at 1000 Hz.

Men's jacket design was developed for evaluation of proposed clothing design solutions.

Cold weather men's jacket with straight outlines, large volume, with closure. The item is intended for cold conditions at average temperature of -10 to -15 degrees Centigrade. The jacket top fabric is Savior. This fabric is defined based on research performed during the works. Insulation is fibertec.

Elbow sections have special additional parts. They are made based on recommendations on enhancement of noise protection for critical human body parts. The materials of special protective overlays included a layer of "Kevlar (2 layers), ("Geom") + stockinet". The developed technology of shape geometry change was used during design of this jacket model.

It is essential to check ultimate level of thermal comfort for a person in such protective clothing. Experimental research was performed for this purpose under natural conditions at temperature of -10 degrees Centigrade using thermal-imaging diagnostics. Protective jacket experimental sample test results using new technologies in special wear design is presented at Fig. 15.



Fig. 15. Thermal imaging test of protective jacket experimental sample

Analysis of Fig. 15 and associated data obtained simultaneously by contact sensor control over clothed body temperature in cold air showed that temperature distribution underclothing and inside its layers is uniform, while skin temperature preserves comfortable characteristics when surface protection is removed.

Conclusion

Thus, the presented research methods and results allowed establishing new structural specifications for thermally resistant textile materials. Polotno type material with thread interweaving with additional fire and water protective finishing was defined as the most effective material among relevant materials. New sets of materials with enhanced noise protection were experimentally justified based on such fabrics. Special equipment was developed for research and a new method of geometrical deformation of clothing material layers was proposed.

An experimental sample of cold weather protective jacket was developed and tested based on the data obtained. Test results confirmed standard level of thermal comfort for a person in clothes. The obtained data and developments represent new results both for science and practice and are highly promising for use and development of clothes with integrated protection against thermal flows, fire, water and noise.

Acknowledgement

The results of researches which this paper has presented are got with the financial support of the Ministry of Education and Science of the Russian Federation (Project №2838). Researches were conducted in Don state technical university.

References

[1] Gabriele, K.-M.A. and Endliche, W.R. 2011, Urban and rural mortality rates during heat waves in Berlin and Brandenburg, Germany. *Environmental Pollution*. № 159. pp. 2044-2050.

[2] Moran, E.F., 1981, Human Adaptation to Arctic Zones. *Annual Review of Anthropology*. №10, pp. 1-25.

[3] Liu, L. and Kim, A.K., 2000. Review of Water mist fire suppression systems – Fundamental Studies. *Journal of Fire Protection Engineering*. №4. pp.32-50.

[4] Cherunova, I.V., Kuznetsov, D.M. and Cherunova, E.S., 2013. Acoustic emission of liquid at flexible porous materials impregnation *Material Sciens*. №3. pp.37-41.

[5] Cherunova, P.V., Cherunova, I.V., Knyazeva, S.V., Stenkina, M.P., Stefanova, E.B. and Kornev, N.V., 2015. The development of the Research techniques of structure and properties of composite textile materials when interacting with viscous fractions of hydrocarbon compounds. *Proc. VI International Conference on textile composites and inflatable structures, Structure membranes*, 19-21 October 2015, Barcelona, Spain.

[6] Successful noise management in manufacturing. *WorkSafe*. Online only publication. (February 2008) URL: https://www.commerce.wa.gov.au/sites/default/files/atoms/files/successful_noise_man.pdf.

[7] Smagowska, B., 2013. Effects of Ultrasonic Noise on the Human Body – A Bibliographic Review. *International Journal of Occupational Safety and Ergonomics*. Vol. 19. No. 2. pp.195-202.

[8] Özçelik, G., Çay, A. and Kirtay, E., 2007. A Study of the Thermal Prop of Textured Knitted Fabrics. *FIBRES & TEXTILES in Eastern Europe* January. Vol. 15). № 1 (60). pp.55-58.

[9] Pan, N., 2007. quantification and evaluation of human tactile sense towards fabrics. *Int. Journal of Design & Nature*. Vol. 1, No. 1. pp.48-60.

[10] Varga, K., Noisternig, M.F., Griesser, U.J., Alja, L. and Koch, T., 2011. Thermal and sorption study of flame-resistant fibers. *Lenzinger Berichte*. №89. pp. 50-59.

[11] Wadje, P.R., 2007. Textile – Fibre to Fabric Processing. 2009. *IE(I) Journal-TX*. Vol 90. pp. 28-36.

[12] Glushakov, G.A., 2007. Tchaykovsky textil – control kachestva nf kazhdom ‘tape I maksimalny servis. *Associaciya SIZ: Vestnik*. № 3. pp. 2-9.

[13] Pustyl’nik, Ia.I., 2002 *Intelligentnaia odezhda, zashchishchaiushchaia ot bysokiln temperature i ognia*. 2002. *Rabochaia odezhda [Workwear]*. №5 (17) 2002. pp. 6.

[14] Carrington Career and Workwear Ltd., 2014. *Textime* / URL: <http://www.textime.ru/brand/199/>.

[15] Saviour, 2014. *Textime* / URL: http://www.textime.ru/material/zaschita_ot_syiroy_n_efti/987?sphrase_id=28388/

[16] Charles, Q.Y. and Yang, H., 2007. The Flame Retardant Nomex/cotton and Nylon/Cotton Blend Fabrics for Protective Clothing. *Advances in Modern Woven Fabrics Technology*. Vol.10.

- [17] When It Comes To Safety... The Fabric Brand Matters. 2015.
- [18] GOST 29104.11-91 Industrial fabrics. Method for determination of capillarity.
- [19] GOST 12088-77 «Materialy tekstilnye. Metod opredelenija vosduhopronicaemosti».
- [20] European standard En 343:2003 – Protection against rain. 2004. W.L. Gore & Associates GmbH. / Published by W. L. Gore & Associates Editorial support Petra Jackisch, Zentrum für Sicherheitstechnik, Erkrath, Germany.
- [21] Jacobsen, F., Poulsen, T., Rindel, J.H., Gade A.C. and Ohlrich, M. 2011. Fundamentals of acoustics and noise control, 2011. Department of Electrical Engineering. Technical University of Denmark. pp. 180.
- [22] Skrebcova, Yu.V., Kurenova, S.V. and Koslov, S.A., 2012. Nestandartnye metody ocenki akusticheskikh svojstv tekstilnykh materialov, ispol'suemyyh pri proektirovanii specialnoj odechdy. Shvejnaja promyshlennost. - Швейная промышленность. № 1. pp. 27-28.
- [23] Andreeva-Galanina, E.C., Kadyskin, A.V. and Suvorov, G.A., 1970. Shum i shumovaja bolezni. 1970. Leningrad. Medicina. pp. 304.