

## Impact Analysis of D-STATCOM on the Performance of Distribution Relay Protection

R. Ilango\*<sup>1</sup> and Dr.T. Sree Renga Raja<sup>2</sup>

<sup>1</sup>*Department of EEE, MAM School of Engineering,  
Tiruchirappalli, India, 621105.*

<sup>2</sup>*Department of EEE, Anna University  
BIT Campus, Tiruchirappalli, India, 620024.*

*\*Corresponding author, e-mail: ilangorengaraju@gmail.com*

### Abstract

This paper presents the impact analysis of custom power devices such as D-STATCOM on the distribution relay protection. The concept of D- STATCOM model with its control circuit is described. An Indian utility distribution system with D- STATCOM and over current protection is modeled using MATLAB/SIMULINK software. The mathematical equation to validate the effect of D-STATCOM is also derived. The impacts of D-STATCOM on the over current relay performance for different fault condition is analyzed. Simulation results indicate that the presence of the D-STATCOM in the distribution feeder significantly changes the line current seen by the over current relay to be lower or higher than the actual line fault current. Because of this the performances of the over current relay changes.

**Keywords** — Distribution Protection, Distribution FACTS devices, Distribution Static Synchronous Compensator (D-STATCOM), Over Current Relay, Power Quality.

### 1. Introduction

Nowadays the power quality is an important issue in distribution networks. Most power utilities face the problem of power quality degradation; because of using power electronics based loads and non-linear loads. Voltage sag and swell are the major power quality problems in utility distribution network, which affects the sensitive loads connected with it.

Recently, many research efforts have been focused on power quality improvements which address the different ways to mitigate voltage dips, swell

interrupts in transmission and distribution systems using newly available power electronic components [1, 2].

DVR and D-STATCOM are the most effective custom power devices which emerged from the FACTS family. They are used to improve the power quality problems such as voltage sag/swell and also to support the reactive power compensation in the distribution network [3].

Normally the D-STATCOM is connected in the heavy load area to maintain the connecting point voltage nearly stable by injecting or absorbing the real and reactive power into the point of common coupling [4, 5]

Over current protection relays have been widely applied for protecting distribution lines due to their simple operating principle and capabilities to work independently under most circumstances [6].

The presence of the D-STATCOM at the load end changes the voltage and current signals at the relay point of the distribution line in both steady and transient state conditions. Due to this impact the setting of the over current relay will be changed which affects the performance of the protective relay.

Therefore, the conventional over current relay characteristics will not be usable in the presence of D-STATCOM. So nowadays, it is very essential to analyze the impact of custom power devices on the relay protection to design an adaptive relay protective scheme which adjusts new settings in its characteristics considering the impact of distribution FACTS devices.

The performance analysis of the protection relays in presence of various types of FACTS controllers has been investigated by number of researches for the past decade and reported in many literatures [7-10]. The results of these investigations have shown that the presence of FACTS controllers can affect the voltage and current signals at the relay point in both steady state and transient state conditions which intern will affect the performance of the existing protection scheme.

To the best of the authors' knowledge, so far no attempt has been made to investigate the performance of the protective relay in presence of distribution FACTS devices, This paper is the first attempt to study the impact of D-STATCOM on distribution line protection which is essential to design an adaptive protective scheme which adjusts new settings in its characteristics considering the impact of D-STATCOM devices.

In this paper, the basic concept of D-STATCOM is outlined first, and then impact of D-STATCOM on over current relay has been formulated analytically. Finally, with the help of MATLAB simulation software the impact of D-STATCOM on the over current relay for different fault conditions is analyzed.

## **2. Principle Concept of D-STATCOM**

D-STATCOM is a three phase shunt connected power electronics based voltage-source converter, which converts DC input voltage into AC output voltage in order to compensate the active and reactive power needed by the system. The basic configuration of D-STATCOM is shown in the Figure1.

The D-STATCOM mainly consists of DC voltage source behind self-commutated inverters using IGBT and coupling transformer. D-STATCOM controller is highly effective in improving the power quality at the distribution level by making the voltage stable. Normally it is connected near the load, in the distribution system [11].

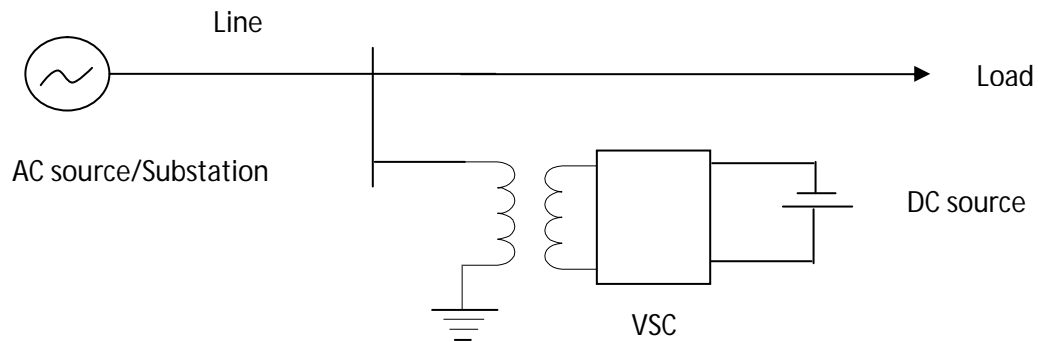

Figure 1 basic configuration of D-STATCOM

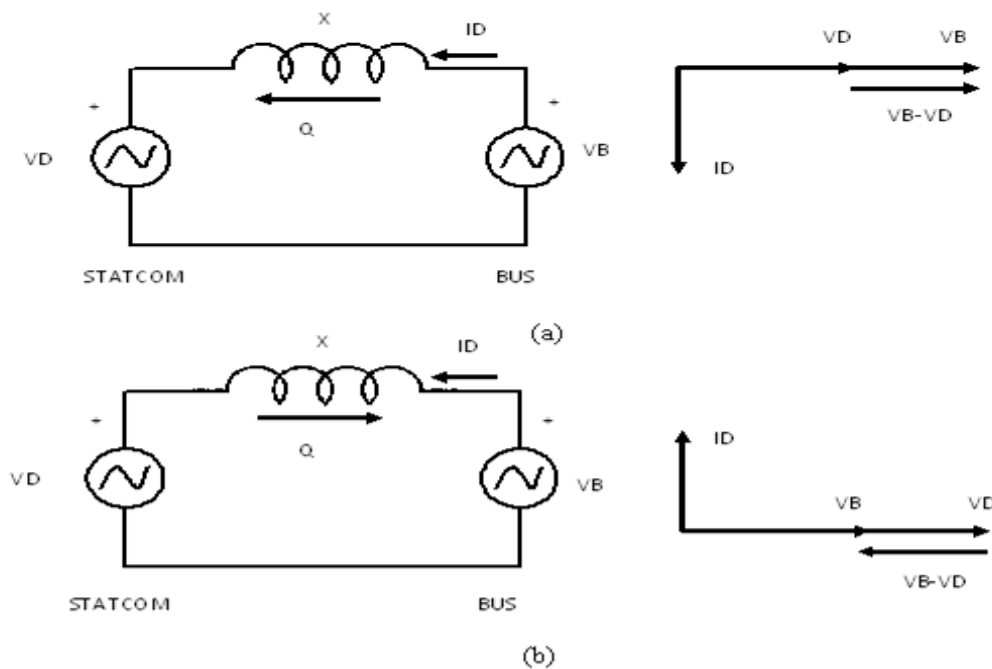

Figure 2 D-STATCOM operation. (a) Inductive operation, (b) Capacitive operation

The basic operation of D-STATCOM for both inductive and capacitive modes is shown in the figure 2. When the secondary voltage ( $V_D$ ) is lower than the bus voltage ( $V_B$ ), the D-STATCOM acts like an inductor absorbing reactive power from

the bus. When the secondary voltage ( $V_D$ ) is higher than the bus voltage ( $V_B$ ), the D-STATCOM acts like a capacitor generating reactive power to the bus [12].

The principle operation of the D-STATCOM depends upon reactive current generation,

$$I = \frac{V - V_0}{X} \quad 1$$

Where,

$V$  is the system voltage

$V_0$  is the output voltage of the IGBT inverter

$X$  is the total circuit reactance

### 3. Mathematical analysis

Per- phase equivalent circuit is convenient to use to represent the three phase fault system. A simple system network with D-STATCOM including three phase fault is shown the figure 3.

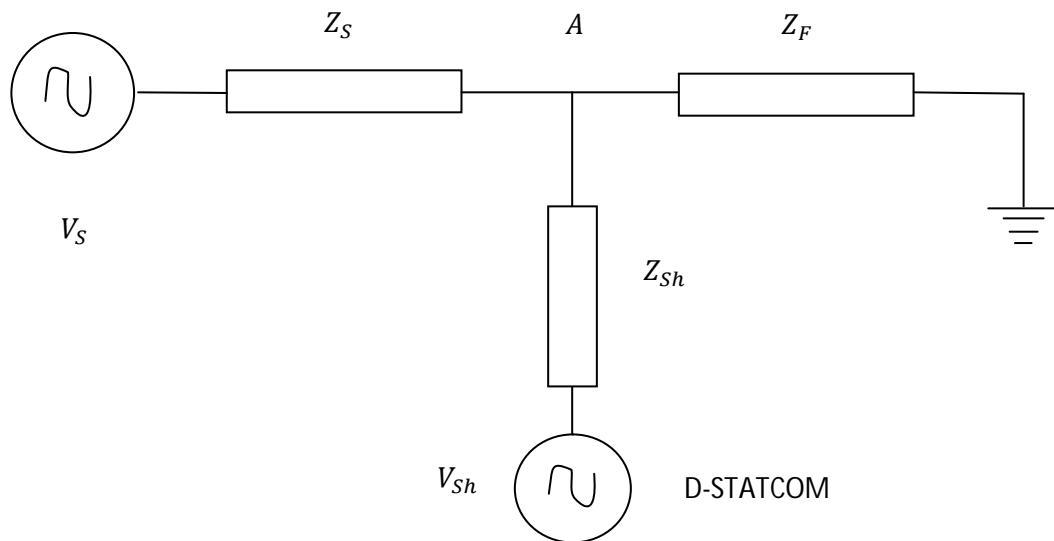

**Figure 3 simplified network of the distribution system**

$V_S$  is the voltage of the distribution system

$V_{Sh}$  is the output voltage of D-STATCOM

$Z_S$  is the impedance of the power source system to the installation point of D-STATCOM

$Z_F$  is the impedance of node 'A' to the fault point

The point of common coupling voltage  $V_A$  is calculated using the equation below

$$V_A = \frac{V_S}{\frac{Z_S}{Z_{Sh}} + 1} + \frac{V_{Sh}}{Z_{Sh}} \times \frac{Z_S}{\frac{Z_S}{Z_{Sh}} + 1} \quad 2$$

Where

$V_A$  is maintained by the value of  $V_{Sh}$  and  $V_S$

$V_{Sh}$  is restricted by DC voltage of the voltage source convertor and output current of the D-STATCOM.

$$V_{Sh} = KV_{dc} \quad 3$$

Where

K is the ratio of modulation

$V_{dc}$  is the DC voltage

The output current of D-STATCOM

$$I_{Sh} = \frac{V_{Sh} - V_A}{Z_{Sh}} \quad 4$$

Then

$$kV_C = V_A + I_{Sh} Z_{Sh} \quad 5$$

The running condition of D-STATCOM is

$$V_{Cmax} > V_C > V_{Cmin}$$

$$max > I_{Sh}$$

Where

$V_{Sh}$  is the *max* and  $V_C$  *min* are upper and lower limits

$I_{Sh}$  is the *max* is the safety limits of D-STATCOM then,

$$V_A = \frac{V_S}{\frac{Z_S}{Z_{Sh}} + 1} + k I_{Sh} \max\left(\frac{Z_S}{Z_{Sh}}\right) \quad 6$$

Without D-STATCOM the  $V_A$  is

$$V_A = \frac{V_S}{\frac{Z_S}{Z_{Sh}} + 1} \quad 7$$

It is evident that from 6 and 7 that the voltage can be improved greatly by reactive power compensation injected by D-STATCOM.

#### 4. Test system

A simplified diagram of a test system of a typical distribution network with D-STATCOM is shown in figure 4. The test system comprises of 11 kV 50 Hz distribution feeder having a load of 1MW, with the 12.5kV D- STATCOM connected at the load point. The instantaneous over-current and the definite time over- current protection which are installed in the feeder are considered for this analysis. The relay settings are 350A and 200A respectively, the time delay of zone I, zone III is 0.1s and 1.2s.

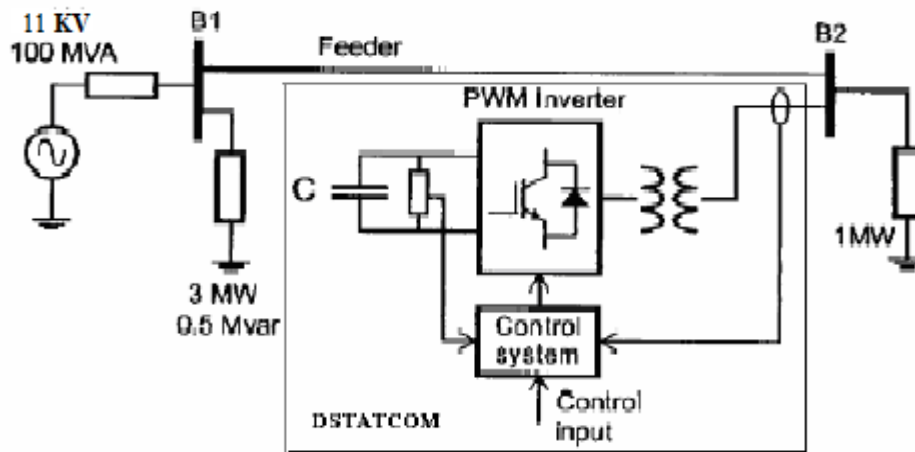

Figure 4 single line diagram of the test system with D-STATCOM

#### 5. Simulation model

To investigate the performance of the protective relay a three-phase short-circuit fault is created in the feeder at 0.4s. The behavior of the relay under the fault condition is investigated with and without installation of D-STATCOM using MATLAB/SIMULINK environment [13]. The simulation model of the test system is shown in figure 5.

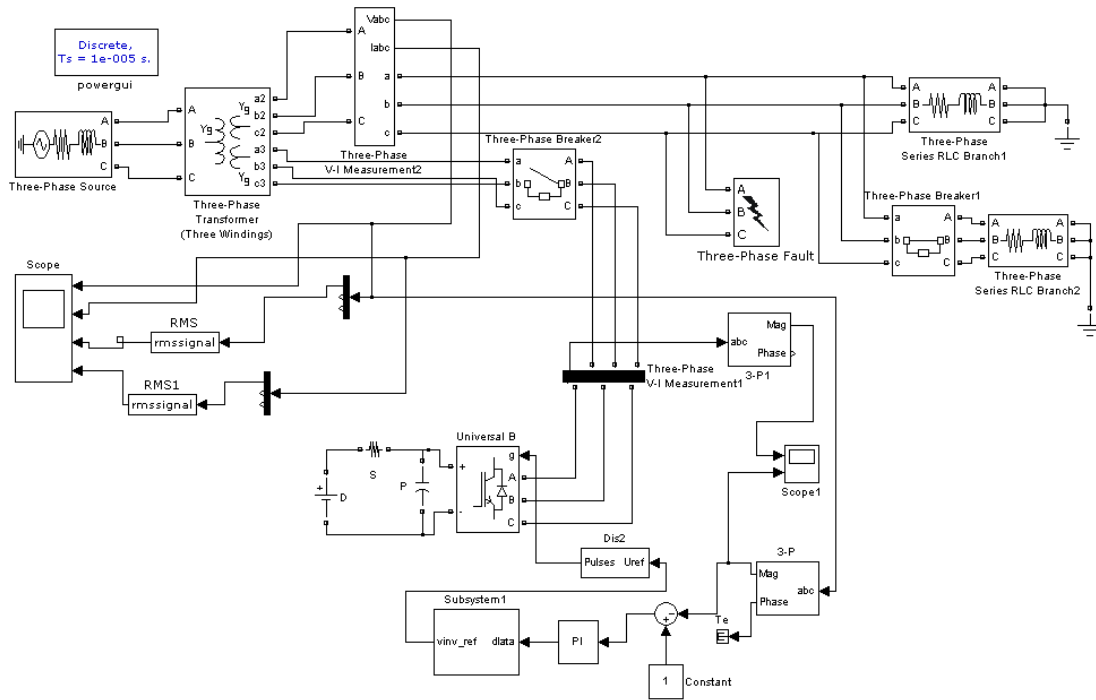

Figure 5 simulation model of the test system

6. Simulation results

6.1 Performance of the voltage

The main bus voltage of pre-and post-fault is 11.kV, 6.5kV respectively are shown in the figure 6. The voltage sag is occurring due to the fault during the time period of 4ms to 8ms without D-STATCOM compensation.

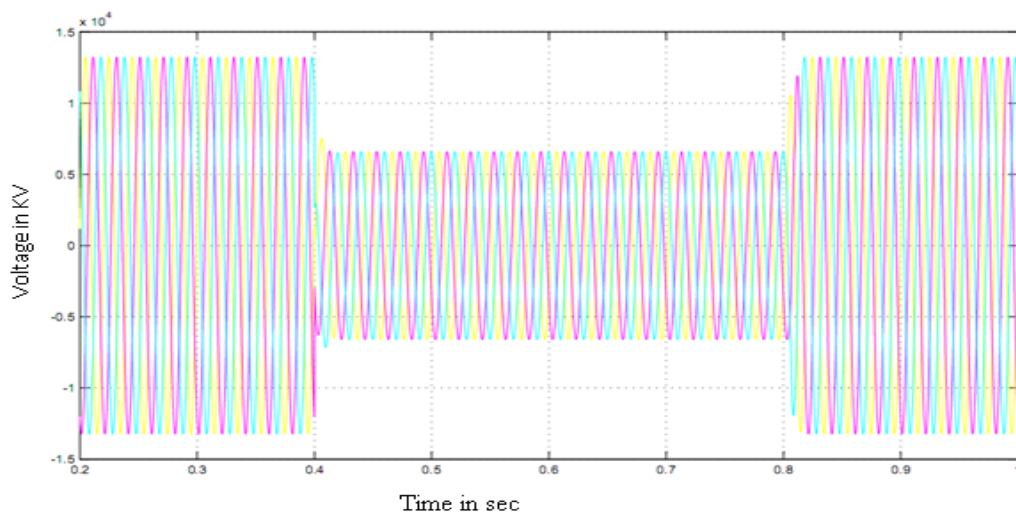
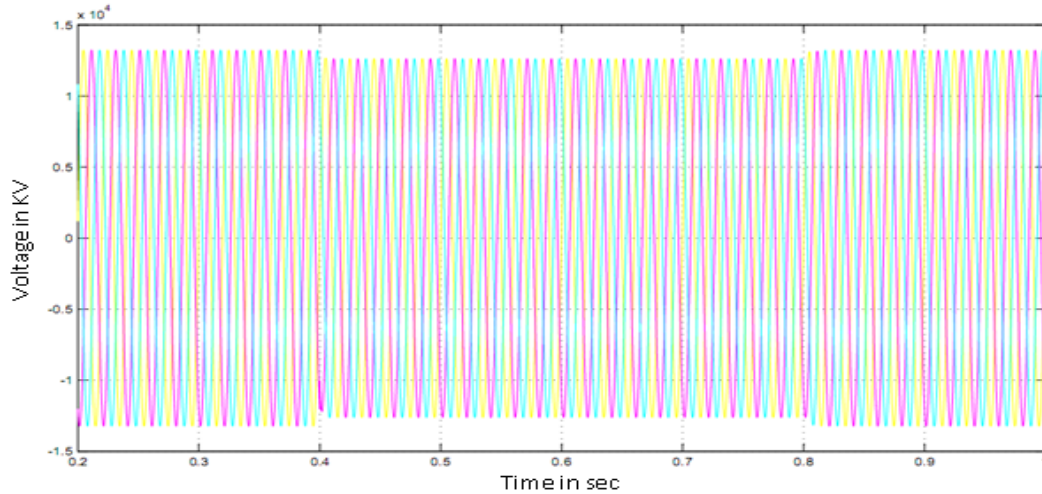

Figure 6 voltage waveform with fault without D-STATCOM

The figure 7 shows the main bus voltage waveform after the implementation of the D-STATCOM. The main bus voltage of pre-and post-fault is 11.2kV, 9.19kV.

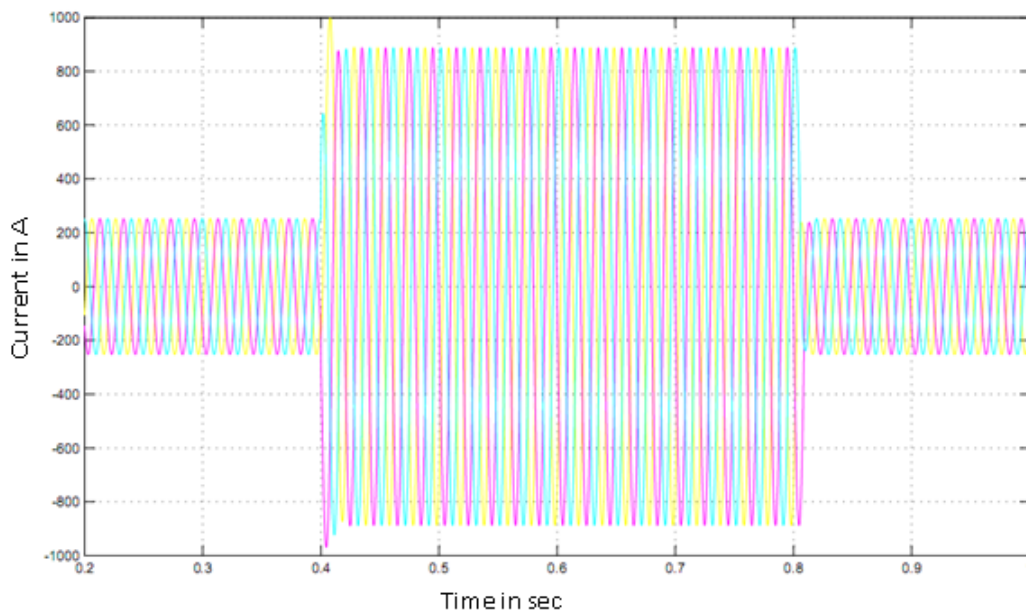

**Figure 7 voltage waveform with fault with D-STATCOM**

From the figure 6 and 7 it is evident that the D- STATCOM improves the voltage profile of the system during fault conditions.

## 6.2 Performance of the current

Figure 8 shows the fault feeder transient current occurring during the time period of 0.4s to 0.8s without D- STATCOM compensation. The pre- and post-fault current of the feeder is 250A, 888A.



**Figure 8 current waveform with fault without D-STATCOM**

Figure 9 shows the current waveform of the test system during the fault condition with D-STATCOM connection. The pre-and post-fault feeder current is 250A, and 340A respectively.

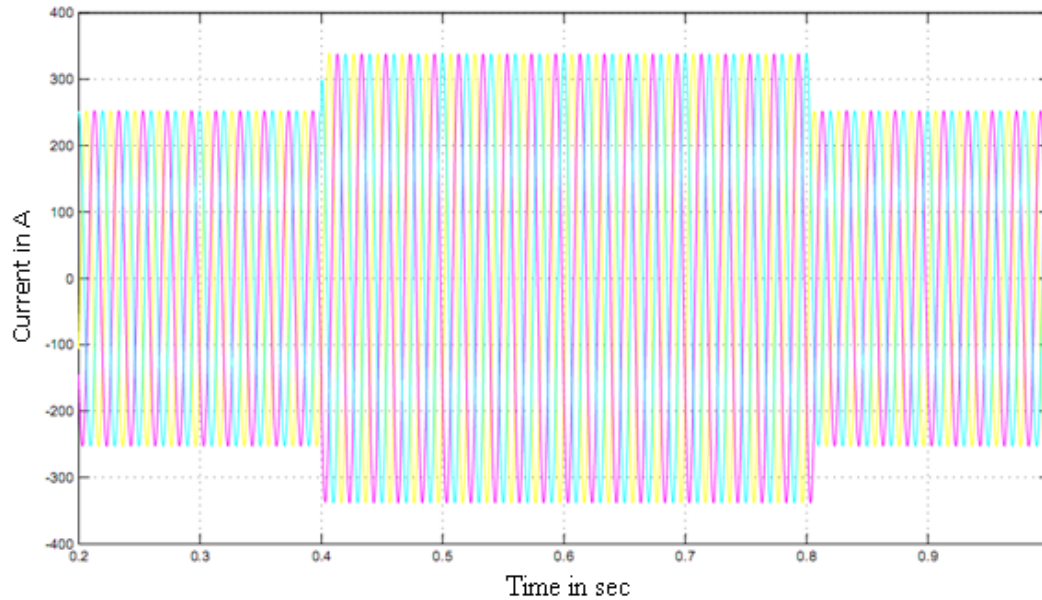
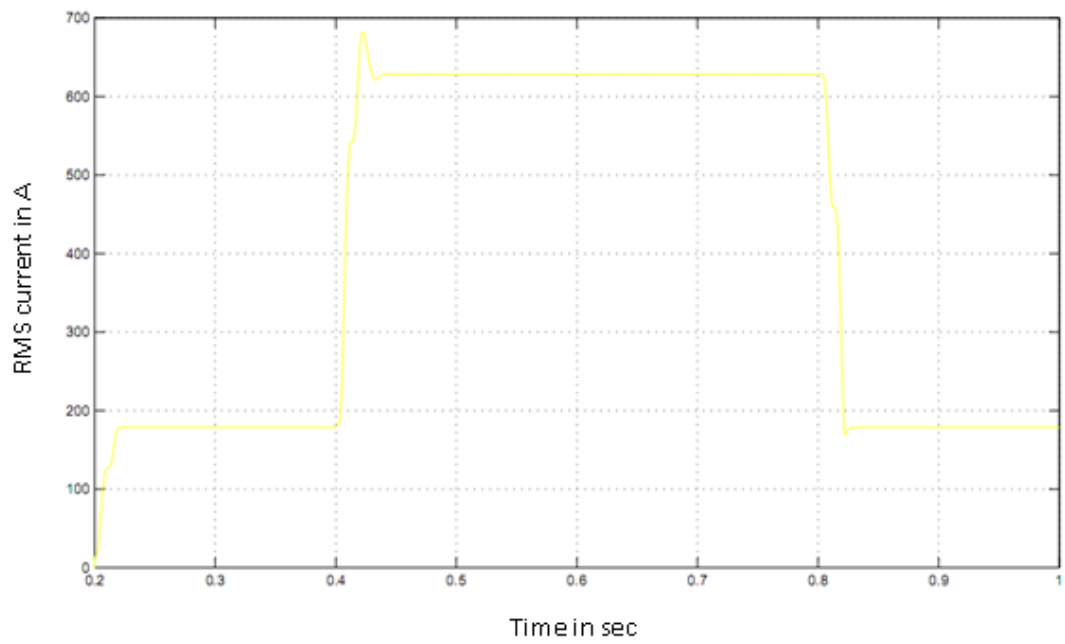

**Figure 9 current waveform with fault with D- STATCOM**

From the figure 8 and 9 it is proved that after connecting the D-STATCOM current profile also improved.

### **6.3 RMS values of fault current with and without D-STATCOM**

The figure 10 shows the RMS value of the fault current during the fault condition without connecting the D-STATCOM which is 625 A. The RMS value of the fault current is 240A as shown in the Figure 11 when the D-STATCOM is connected at the point 'A' the instantaneous over-current protection of zone I fails to operate, definite time over-current protection of zone III is started at 1.53s.



**Figure 10 RMS fault current without D-STATCOM**

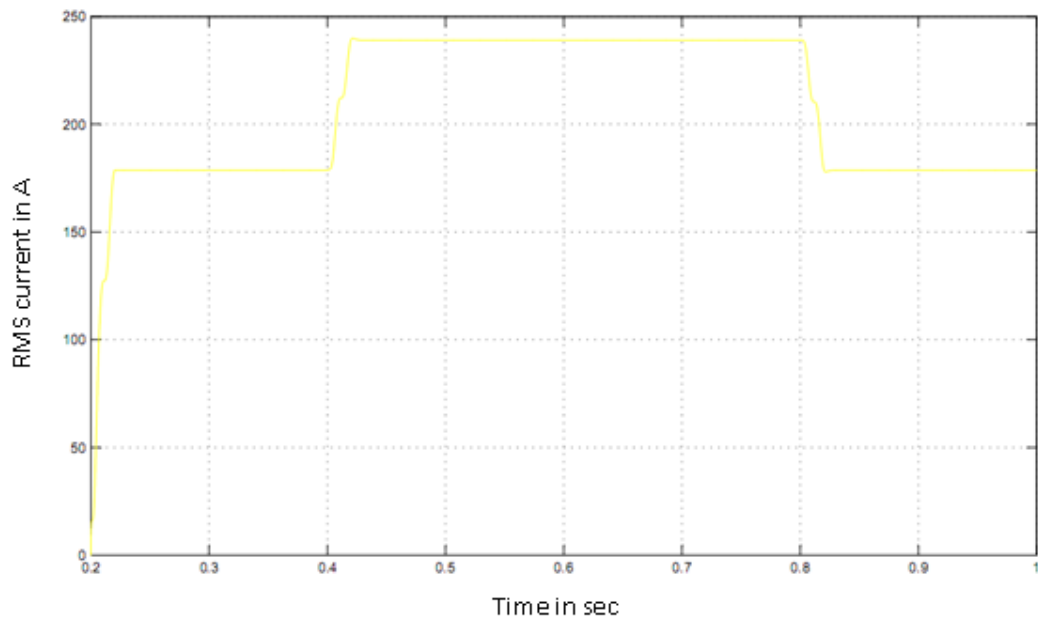

**Figure 11 RMS fault current with D-STATCOM**

#### 6.4 Discussions

Simulation results show that the D-STATCOM improves the bus voltage by injecting the reactive power. From the simulation results it is obvious that during a fault, the RMS fault current decreases if the D-STATCOM supplies reactive current to the system that is the impulse fault current is reduced, but the selectivity of the current protection is impacted.

#### 7. Conclusion

The performance of the over current relay in the presence of D-STATCOM has been analyzed for three phase fault conditions using MATLAB/ SIMULINK software. The results clearly show that the connection of the D-STATCOM in the distribution line affects the performance of the over current relay. During fault conditions the injected or absorbed reactive current of the D-STATCOM results an error in the over current relay measurement. Therefore, when a transmission line is compensated by shunt distribution FACTS devices such as D-STATCOM the over current relay settings should be adjusted according to the system conditions to avoid wrong operation.

#### REFERENCES

- [1] A.Ghosh, and G.Ledwich. "Power Quality Enhancement using Custom Power Devices" Kluwer Academic Publisher 2002. ISBN 1-4020-7180-9.
- [2] Pradeep Kumar, "Simulation of Custom Power Electronic Device D-STATCOM - A Case Study", *IEEE Transactions on Power Delivery*, 2011.
- [3] S.V.RaviKumar and S.SivaNagaraju, "Simulation of D-STATCOM and DVR in Power Systems", *ARPJ Journal of Engineering and Applied Sciences*, vol. no.3, June 2007.
- [4] P.S.Sensarma, K.R.Padiyar, and V.Ramanarayanan,. "Analysis and Performance Evaluation of a Distribution STATCOM for Compensating Voltage Fluctuations", *IEEE Trans. Power Delivery*, vol.16, no.2, pp.259–264, May 2001.
- [5] S.M.Woo, D.W.Kang, W.C.Lee, and D.S.Hyum, "The Distribution STATCOM for Reducing the Effect of Voltage Sag and Swell", *IECON'01*, vol. 2, pp. 1132-1137, 2001.
- [6] Network Protection & Automation Guide Third Ed: ALSTOM, 2002.
- [7] M.Khederzadeh, "The Impact of FACTS Device on Digital Multifunctional Protective Relays," in *Proc. IEEE/PES Transmission and Distribution Conf. and Exhib. 2002: Asia Pacific*, vol. 3, Oct. 6–10, 2002, pp. 2043–2048.
- [8] T.S.Sidhu, R.K.Varma, P.K.Gangadharan, F.A.Albasri, and G.R.Ortiz, "Performance of Distance Relays on Shunt—FACTS Compensated Transmission Lines," *IEEE Trans. Power Del.*, vol. 20, no. 3, pp 1837–1845, Jul. 2005.
- [9] F.A.Albasri, T.S.Sidhu, and R.K.Varma, "Impact of Shunt-FACTS on Distance Protection of Transmission lines", in *Proc. 2006 Power Systems*

- Conference: Advanced Metering, Protection, Control, Communication, and Distributed Resources, PS'06*, pp.249–256.
- [10] Dash PK, Pradhan A K, Panda G, and Liew AC. Digital Protection of Power Transmission lines in the Presence of Series Connected FACTS Devices. *Proceedings in IEEE Power Engineering Society Winter Meeting*. 2000 Jan; 3(23–27): 1967–1972.
- [11] M.G.Molina and P.E.Mercado, “Control Design and Simulation of D-STATCOM with Energy Storage for Power Quality Improvements”, in *Proc. IEEE/PES Trans. 4 Distrib. l.a. Caracon*, Venezuela, 2006.
- [12] Adzic, M.E., Grabic, S.U., and Katic, V.A., “Analysis and Control Design of STATCOM in Distribution Network Voltage Control Mode”, *Sixth International Symposium Nikola Tesla*, 2006.
- [13] The Math works, Inc., MATLAB Help Manual, Natick, MA: Author, Chaps.1 and 3, 2009.