

A Novel Approach In Increasing Power Quality Using Cascaded Multilevel Inverter Based Statcom

G.Sundar¹, R.Vinothini², M.Divya Menon³

*^{1,2}Department of Electrical and Electronics Engineering.,
Arulmigu Meenakshi Amman College of Engineering, Kanchipuram, Tamil Nadu,
India.*

*E-mail: sund_geee@yahoo.co.in, bestway2vino@gmail.com,
divyamenonsree@gmail.com*

Abstract

This paper investigates a novel approach in increasing power quality using cascaded multilevel inverter based STATCOM. The main objective of this paper is to reduce the total harmonic distortion and improve the power quality. The multi level inverter generates sinusoidal voltage waveforms from several DC voltage sources. Multi level voltage source inverters are the new development area of power electronics these are mainly applied in the field of medium and high power applications. In this paper, the design and implementation of a twenty six level cascade H bridge converter (CHB) based static synchronous compensator (STATCOM) employing an effective modulation control technique have been implemented and simulated in a MATLAB Simulink environment.

Keywords: Reactive power compensation, STATCOM, 26 Multilevel inverters, pulse width modulation (PWM), Total Harmonic Distortion (THD).

Introduction

Day by day the field of application of electricity increases and the power system networks get more complicated. In order to make it reliable in operation, to maintain the power quality. Power distribution system power should be provided, by fulfilling the objectives such as uninterrupted and smooth flow of energy, and also achieving a contracted magnitude level to their customers. The uses of nonlinear, inductive, capacitive loads, produces various distortions in sinusoidal voltage waveform. This will badly affect the power quality. Power quality, mainly depends on voltage. There are different approaches available to maintain the power quality.

The need for more efficient electricity systems management has given rise to innovative technologies in power generation and transmission. The combined cycle

power station is a good example of a new development in power generation and flexible AC transmission systems, FACTS as they are generally known, are new devices that improve transmission systems. Worldwide transmission systems are undergoing continuous changes and restructuring. They are becoming more heavily loaded and are being operated in ways not originally envisioned. Transmission systems must be flexible to react to more diverse generation and load patterns. In addition, the economical utilization of transmission system assets is of vital importance to enable utilities in industrialized countries to remain competitive and to survive. In developing countries, the optimized use of transmission systems investments is also important to support the industry, create employment and utilize efficiently scarce economic resources.

The Voltage Source Converter (VSC) that meets the Practices and requirements for Harmonic Control in Electrical Power Systems is performed, and emphasizes its development through Matlab simulations. Lower Total Harmonic Distortion (THD) that this VSC produces allows this power conditioner to be considered for its use of stringent applications or in the reactive power compensation and the power quality improvement. Multi level inverters are implemented in STATCOM in order to improve the performance of the system. Multi level inverters produce output in steps and reduces the total harmonic distortion.

Statcom Configuration

A functional model of STATCOM is shown in figure 1. STATCOM comprises of coupling transformer, VSC and a DC energy storage device.

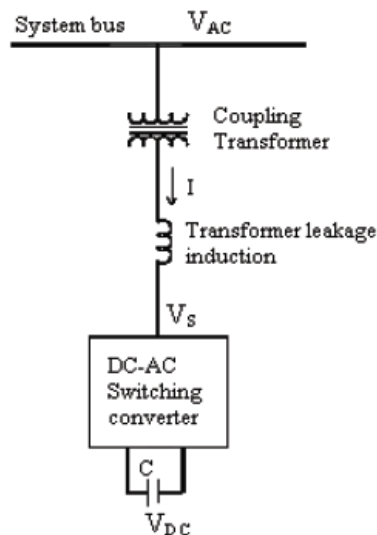

Figure 1: Functional Model of STATCOM

STATCOM is a second generation shunt connected device, with the help of advanced power electronics devices, it controls the power flow and hence improve the reliability of the system. By injecting or absorbing the reactive power the terminal

voltage of the system can be maintained. The power electronics devices are used for switching purposes and the generation of step voltage waveform from the DC voltage sources.

It can be seen that if the voltage across the STATCOM is higher than the system voltage the STATCOM it will supply the reactive power to the system. On the other STATCOM will absorb the reactive power. When both voltages are equal STATCOM will be in floating condition that is there will be no exchange of power.

Multilevel Inverter Configuration

The structure of cascaded multilevel inverter is shown in fig.2. The voltage source converter or inverter (VSC or VSI) is the main part of STATCOM device and any other FACTS devices. The main function of a good VSI converter is to produce the sinusoidal voltage waveform with reduced waveform distortion and harmonic content. Nowadays, multilevel inverters obtained more attention for their capability on high power and medium voltage operation and because of other advantages like high power quality, low switching losses, and reduced harmonic distortion and better electromagnetic interference.

By the proper arrangement of power semiconductor based devices the inverters generate stepped voltage waveforms. The term multilevel began with the three level inverters subsequently; several multilevel inverter topologies have been developed. Diode clamped multilevel inverters, flying capacitor multilevel inverters, and cascaded multilevel inverters are the basic three types multilevel inverters. In recent years, several topologies with various control techniques have been presented for cascaded multilevel inverters. But the main disadvantage of these techniques are with increasing number of levels there will be the highest number of bidirectional power switches, a high number of insulated gate bipolar transistors (IGBTs) are required.

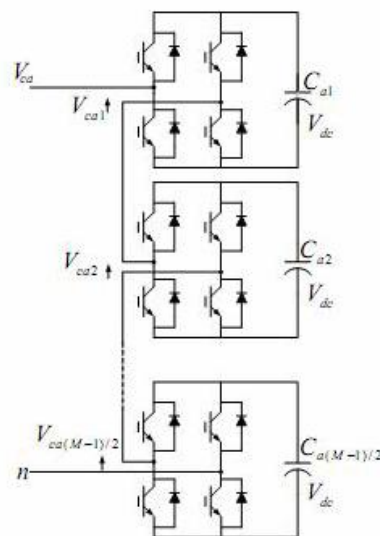

Figure 2: cascaded multilevel inverter

Simulation and Results

The proposed power system STATCOM simulation model is shown in Fig.3. The model is designed of 3 phase source and line voltage of 11KV.

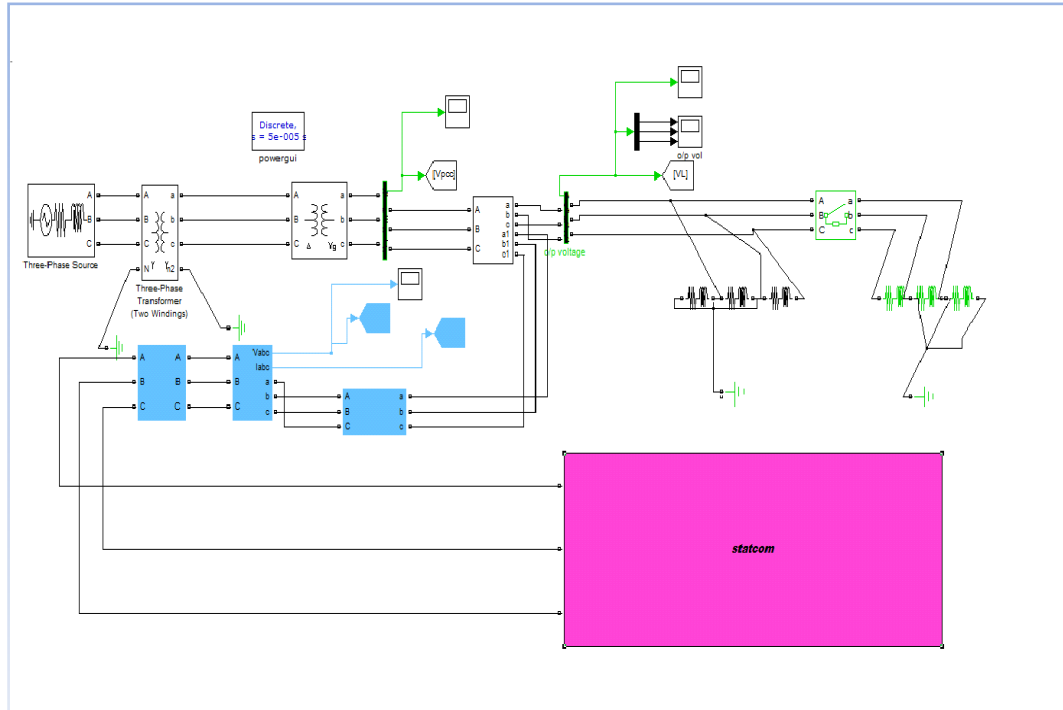

Figure 3: STATCOM Simulation model

The Fig.4 shows the multilevel inverter of twenty six level inverter using new topology. The main objective is to improve the power quality with reduced number of components.

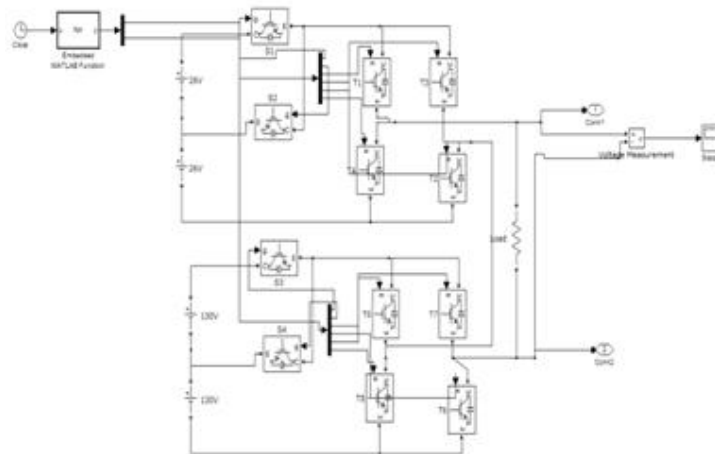

Figure 4: Twenty six level multilevel inverters

The output voltage waveform of twenty six level inverters is shown in Fig.5. The staircase waveform obtained by switching action of IGBT switches. As the number of levels increases the power quality will also get improved.

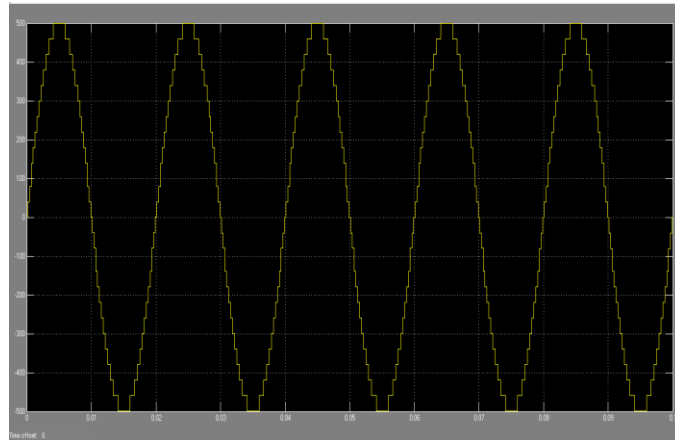

Figure 5: Twenty six level inverter output voltage waveform

In twenty six level multilevel inverters, the real and reactive power variations are within the limits and the reactive power compensation is uniform. So it will improve the power quality and reduce the harmonics that can be evaluated by FFT analysis. The output of real and reactive power compensation waveforms are shown in Fig. 6.

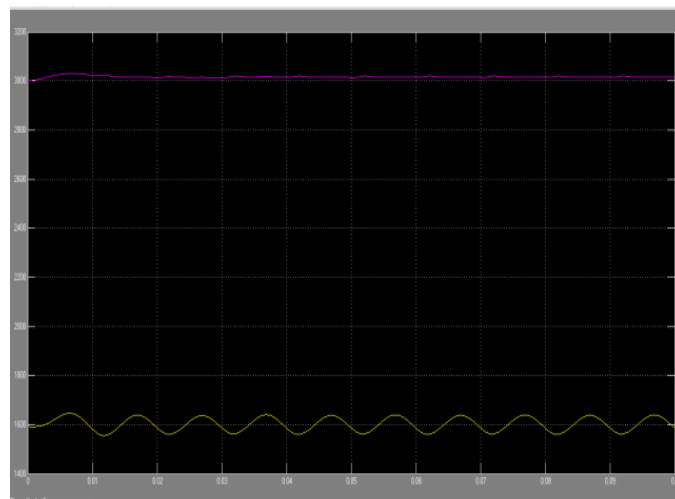

Figure 6: Output of Real and reactive compensation

It can be seen that the harmonic distortion is very low. This indicates that the power quality gets improved and there will be low distortions present in the system. The performance of the network got improved and it can be utilized effectively. The

Total Harmonic Distortion (THD) of Twenty six multilevel inverter value is 0.12%, shown in Fig.7.

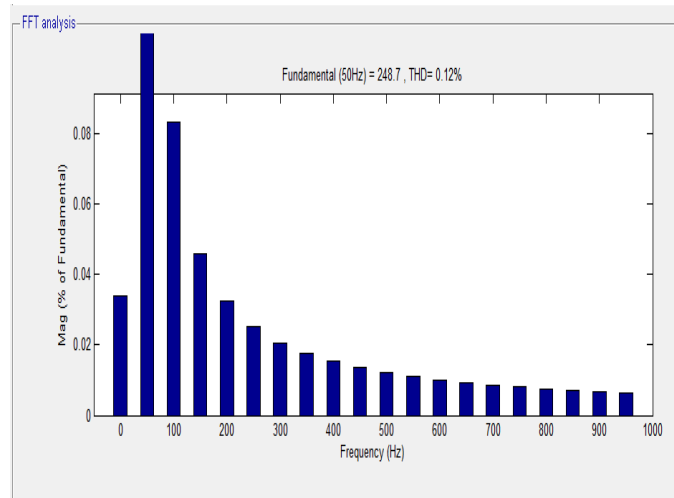

Figure 7: Total Harmonic Distortion of Twenty six multilevel inverters

Conclusion

The Twenty six level inverter fed STATCOM are simulated using the blocks of Simulink and the results of the systems are presented. It is observed that the presence of total harmonic distortion by twenty six level inverter system is less than that of a seven level inverter. In order to increase the number of levels of output voltage, and reduce the number of power switches, driver circuits to increase the number and total cost of an inverter, a new topology of cascaded multilevel inverter is proposed. Finally, the performance of the proposed topology in generating all voltage levels with better power quality through a 26 level inverter has been achieved using MATLAB Simulink.

References

- [1]. S.Bandopadhyay and A.Roy, 2014, "Digital simulation of 48 pulse GTO based STATCOM and reactive power compensation", International journal on recent and innovation trends in computing and communication, Vol. 2, pp. 824–827.
- [2]. F. Bianchi and O. Gomis-bellmunt, 1998, "Optimal Control of VSC for STATCOM Applications," "Power plants and power systems control", vol. 8, (1), pp. 588-593.
- [3]. T. Mittal, N. S. Tung, A. D. Diwan, and K. Janardhana, 2012, "STATCOM Analysis for improving Power Quality Constraints - A Literature Survey," "IJERSTE" vol. 1, (1), pp. 1–10.

- [4]. S. Pal, S. Dalapati, and N. C. Ganguly, 2012, "Application of Multilevel Voltage-Source-Converter in FACTS Devices for Power System Voltage Control & Reactive Power Compensation," "International journal of modern engineering research (IJMER)" Vol. 2, (6), pp. 4201–4206.
- [5]. P. Balyan, 2014, "Cascaded multilevel inverter based on STATCOM," "International journal of advanced technology in engineering and science", Vol. 02, pp. 42–51.
- [6]. Nwohu Mark Ndubuka, 2011, "Effects of Static Synchronous Compensator (STATCOM) on voltage stability and transmission losses of electric power systems." "International journal of electrical and power engineering", Vol.5, (1), pp. 13-17.
- [7]. K.-S. Jeong, T.-Y. Jyung, and Y.-S. Baek, 2011, "Modeling and Dynamic Analysis of STATCOM for Short-Term Voltage Stability Improvement using EMTP/RV," "Journal of International Council on Electrical Engineering", Vol. 1, (2), pp. 129–134.
- [8]. S. Pal, S. Dalapati, S. Biswas, and S. S. Ghosh, 2012, "Digital simulation of a STATCOM based on twelve pulse VSC for voltage control application in power system" "Indian journal of scientific research" Vol. 3, (2), pp. 135–144.
- [9]. K. V Soumya and P. Gayathri, 2014, "Improvement of Voltage Profile by 84-Pulse VSC Configuration Using Multi-Level Converter Using STATCOM" "International journal of science and research"(IJSR) Vol. 3, (5), pp. 535–542.
- [10]. S.Mahendran, I.Gnanambal. K.gobinath, 2013, "New cascaded h-bridge multilevel inverter with improved efficiency," "International journal of advanced research in electrical,electronics and instrumentation engineering" Vol. 2, (4), pp. 1263–1271.
- [11]. Deepshikha singla, Dr. P.R. Sharma, Dr.Narender Hooda, 2011, "Power quality improvement using multilevel inverters a review." "International journal of engineering sciences & management(IJESM)", Vol.1, (1), pp.64-76.
- [12]. E. Babaei, S. Alilu, S. Laali, and S. Member, 2014, "A New General Topology for Cascaded Multilevel Inverters With Reduced Number of Components Based on Developed H-Bridge," "IEEE transactions on industrial electronics" Vol. 61, (8), pp. 3932–3939.
- [13]. P. Sreenath, M. Narendhar, and T. S. Rao, 2013, "Mitigation of Total Harmonics Distortion by Using 84 Pulse VSC Configurations," "International journal of engineering and advanced technology(IJEAT)", Vol.3, (1), pp. 168–170.

