

Design of Ultra Wide Band Microstrip Antenna Using EBG Structures

Sabzar Ahmad Bhat and R. Madhusudhan Goud

Student, Faculty, Lovely Professional University

Abstract

A low profile planar antenna for ultrawideband applications using Electromagnetic Band Gap structures is presented in this paper. The antenna is designed to achieve a bandwidth of 2.5 GHz with a high return loss of -23.4395 dB and minimum voltage standing wave ratio of 1.1. In this design, to exploit the advantage an array of square shaped structures are placed in the top and bottom section of the dielectric layer. And also to avoid mutual coupling between these layers, the substrate is drilled with the help of cylinders. Along with these structures to enhance the radiation characteristics of this antenna, a semicircular structure is introduced in the ground plane. The prototype proposed in this paper is a promising candidate and can be used in emerging technologies like WLAN and many short range applications. The simulations were carried out in AnsoftHFSS V.12.

Index Terms: Electromagnetic Band Gap (EBG) structures, Bandwidth, Mutual Coupling, VSWR, Return loss.

Introduction

Wireless communications have witnessed a tremendous growth and implementation in the variety of applications. There has been an increasing demand in low profile, low cost, light weight and wideband systems. Wide band systems promise high bandwidth, reduced fading from multipath and low power requirements. One of the antennas that meet these requirements is the Microstrip antenna but suffers from less bandwidth. Microstrip antennas are low profile, light weight and low cost antennas that are conformable to both planar as well as non-planar surfaces. These antennas became very popular because it proved to be an excellent radiator for many applications [1]. With its advantages, it also has many disadvantages such as narrow bandwidth and low gain and existence of the surface waves. There are several ways to overcome these disadvantages one such method is using EBG structures. EBG structure is used to reduce the effect of the surface waves which are excited on the

Microstrip antenna. These surface waves are propelled from the substrate and reflected from the ground and cause the radiation at the edges of the substrate and result in then reduced efficiency and gain of the antenna [2].

Electromagnetic band gap structures sometimes called as photonic band gap materials are the artificially engineered objects that avert the propagation of electromagnetic waves in a specified band of frequency. These structures have interesting properties which cannot be seen in the natural materials such as they reflect incident plane wave's in-phase rather than out of the phase (phase response changes from 180° to -180°) when the frequency increases which has engrossed increase in the research interests [3].

There are the different kinds of the EBG structures which have been reported in [4]. One of the EBG structures that have been reported is the mushroom EBG structure which consists of the patches which are arranged periodically, vias which is allied to patches and the ground plane which is shown in figure 4 and modeled as the LC parallel resonant circuit. This LC circuit acts as a filter and blocks the movement of the surface waves. The capacitor results from the gap between the adjacent patches while as the inductor results from the current flowing along adjacent patches. The impedance of the LC circuit was reported in [4]. The impedance becomes inductive and a supports TM surface waves at the low frequencies while as at high frequencies the impedance becomes capacitive and supports TE waves, the high impedance is achieved close to the resonance frequency which results in the frequency band gap and EBG does not support the surface waves [4].

Antenna Design

A. Microstrip patch Antenna

In this paper, the Microstrip patch antenna embedded with the EBG structure is proposed. The antenna was designed using FR4 substrate ($\epsilon_r=4.7$) of dimensions 35 mm \times 35 mm at the height of 3.2 mm. The proposed antenna consists of the semicircular ground plane and the semicircular radiator of the radius 15 mm and 12 mm respectively as shown in the figure 1. The aim of designing the semicircular ground was to create the adjacent staggered resonance modes.

To compare the reflection coefficient, VSWR and impedance bandwidth of the antenna it is required to design a reference antenna. The reference antenna was designed with the radiator dimensions of 24mm \times 12mm on FR4 substrate ($\epsilon_r = 4.7$) with feed line length and width of 16mm and 1.9mm respectively. The geometry of the designed reference antenna is shown in the figure 2.

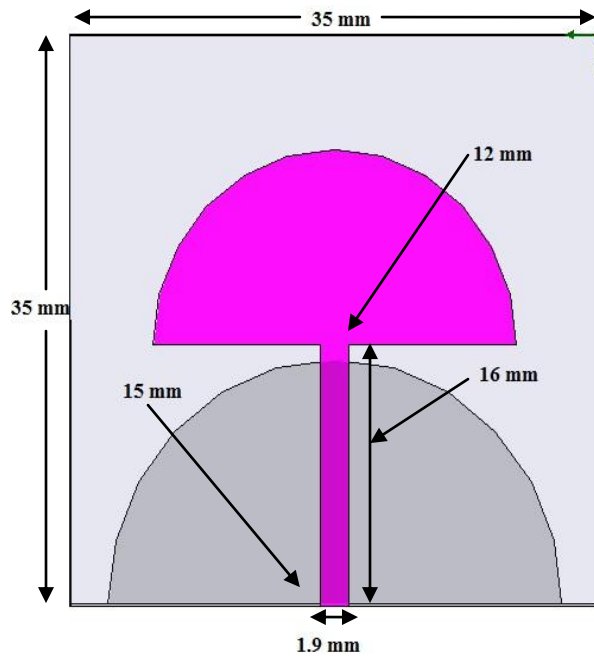

Figure 1: Proposed Microstrip Patch Antenna

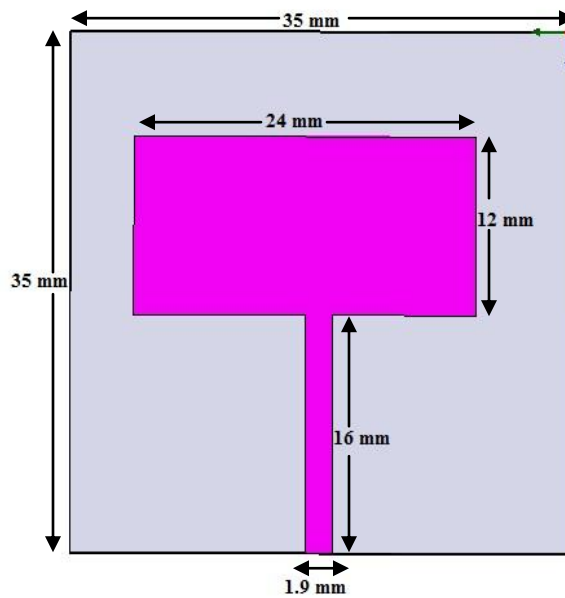

Figure 2: Reference Microstrip Antenna

The Microstrip feed line was designed with the length of 16 mm and the width of 1.9 mm as shown in the figure 1. The antenna was excited with the lumped port at the impedance 50Ω as shown in the color portion of the figure 3.



Figure 3:LumpedPort Excitation Shown In Color Portion

B. EBG Structures

For EBG structures are the four parameters which effect their performance are patch width (W), gap width (g), substrate thickness (h) and substrate permittivity (ϵ_r). In determining the resonant frequency the patch width plays an important role. The patch width can be changed from $0.04 \lambda_g$ to $0.20 \lambda_g$ [4].The wider patch width results in the larger capacitance (C) which inturn results in the narrow bandwidth. The value capacitance of the is calculated from the equation (1) as:

$$C = \frac{W \epsilon_o (1 + \epsilon_r)}{\Pi} \cosh^{-1} \left(\frac{W + g}{g} \right) \quad (1)$$

The coupling between the two EBG patches is controlled by the gap width (g) which can be changed from $0.01 \lambda_g$ to $0.12 \lambda_g$ [4].When the value of the gap width is increased the capacitance decreases which results in the increase in the bandwidth.

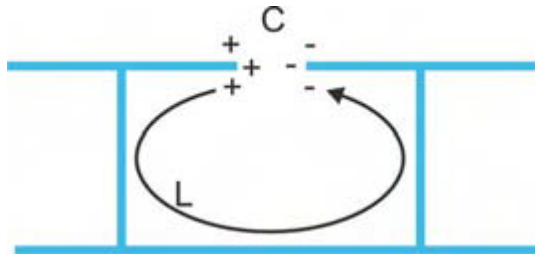

Figure 4:Structure of EBG Cells

If the substrate thickness is increased it results in the increase in the bandwidth because theincrease in theinductance as reported in [4]. The value of the inductance is calculated from the equation (2) as:

$$L = \mu h \quad (2)$$

Where μ is the permeability and h is the thickness of the structure.

The proposed antenna consists of the two layers of the EBG structures on each side of the antenna with patch width(W) of 3.75 mm and the gap (g) between two patches is set at 0.625 mm as shown in colour portion of figure5.

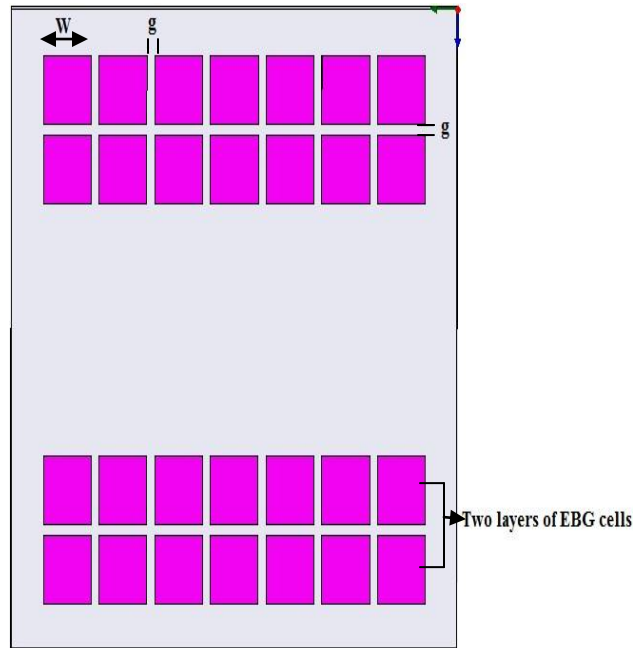

Figure 5:Proposed EBG Structure

The mutual coupling between the two layers is reduced by drilling the cylinders in the substrate of radius equal to 0.3 mm as shown in the figure 6. The operating frequency of the antenna is set at the 5 GHz.

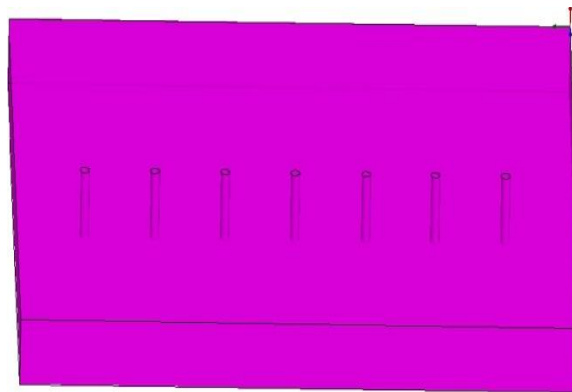

Figure 6: Cylinders Drilled In The Substrate

Simulation and Results

The proposed antenna was simulated using HFSS v.12 tool from where the reflection coefficient, VSWR, gain and the radiation pattern was obtained. The reflection coefficient and the VSWR of the reference antenna resulted in -12.1225 dB and 1.65 respectively as shown in figure 7(a) and 7(b) while the reflection coefficient and the VSWR of the proposed microstrip antenna embedded with EBG structures resulted in -

23.3495 dB and 1.1 respectively and is shown in the figure 8(a) and figure 8(b) The aim of designing this antenna was to achieve a wide bandwidth. The reference antenna has a center frequency 5.0 GHz and the bandwidth obtained at -10dB was 0.55 GHz and fractional bandwidth of 11.0% (4.84 GHz – 5.39 GHz) while as that of the microstrip antenna embedded with EBG structures has center frequency 5.0 GHz and the bandwidth obtained at -10dB was 2.5 GHz and fractional bandwidth of 50% (4.07 GHz – 6.51 GHz).

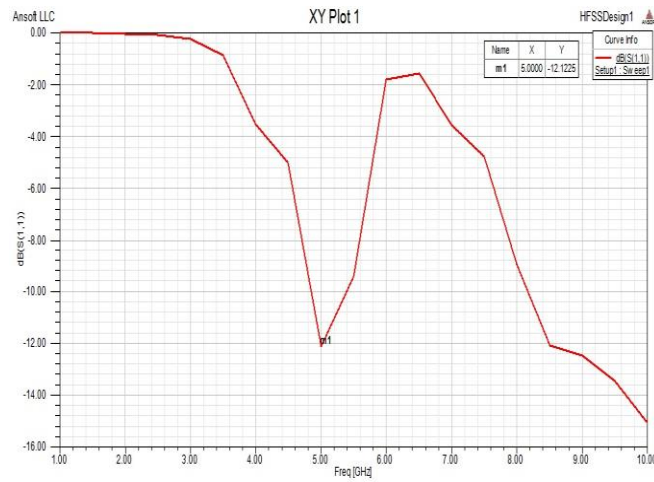

Figure 7(a): S11 Parameter of Reference Antenna

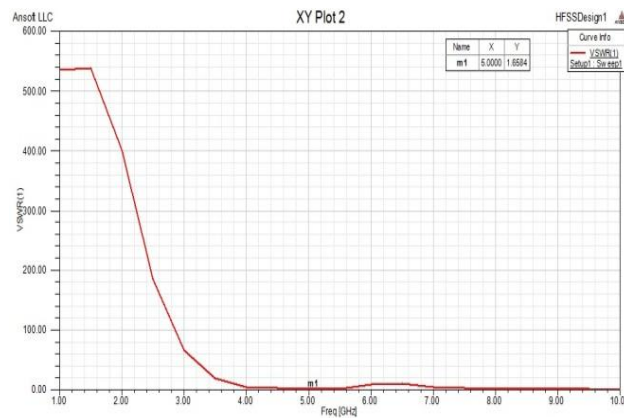

Figure 7(B): VSWR of Reference Antenna

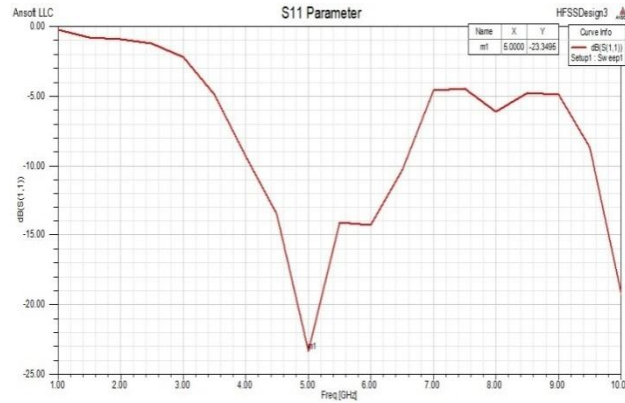

Figure 8(a):S11 Parameter

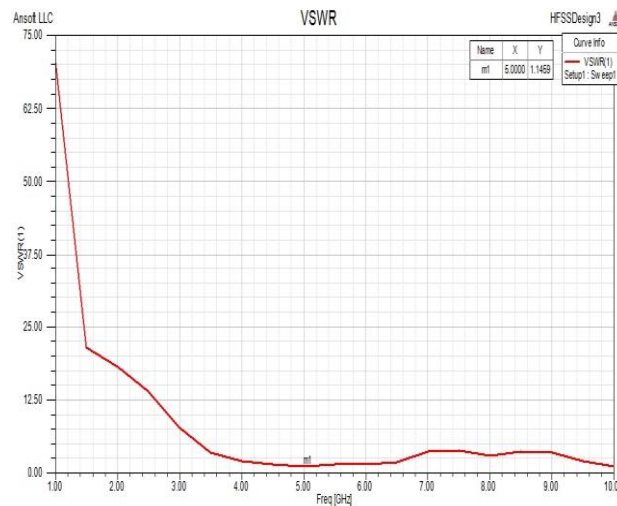

Figure 8(b): VSWR

There are the two effects which enhance and degrade the bandwidth of the proposed antenna one is the parasitic effect and another is the cavity effect. The EBG cells which are placed near the radiating edges of the radiator result in the parasitic effect. The cavity effect comes into the picture as EBG cells reflect back some part of energy that circulates into the substrate as act as reflecting walls around the antenna. This parasitic effect is responsible for enhancing the bandwidth of antenna while as cavity effect degrades the bandwidth of the antenna. Parasitic effect becomes dominant when there are the few rows of EBG which surround the antenna as the number of rows is increased the cavity effect dominates which result in degradation of the bandwidth as more energy circulates along the substrate.

Radiation pattern describes how well antenna radiates and it is determined in the far field region. The simulated radiation pattern of the antenna at 5 GHz is shown in the figure 9.

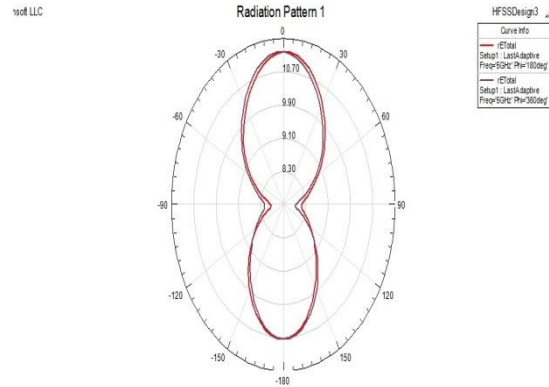

Figure 9: Radiation Pattern

The gain of the antenna describes how much power is transmitted by the antenna in the direction of peak radiation. The 3D gain polar plot of proposed antenna resulted 3.2134 dB and is shown in the figure 10. The gain of the proposed antenna.

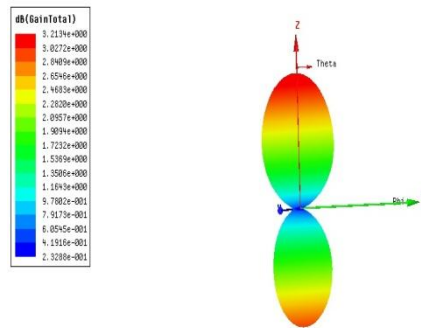

Figure 10: Gain

A.Comparison between two antennas

The below table shows the comparison between the reference antenna and the proposed one.

Table 1: Comparison Table Between Two Antennas

Antenna Shape	S11	VSWR	Band-width	Percentage Bandwidth
Reference Microstrip antenna	-12.1225 dB	1.65	0.55 GHz	11.00%
Microstrip antenna with EBG structure	-23.3495 dB	1.1	2.5 GHz	50.00%

Conclusion

This paper demonstrates the use of EBG structures along with semicircular ground plane to enhance the bandwidth of the Microstrip antenna for UWB applications. The novelty in this approach is shape of the structures and cylinders drilled inside the substrate to cancel out the mutual coupling between them. The fractional bandwidth around the center frequency is achieved to be equal to 50% with a very good return loss of -23.3495. It can also be seen that the VSWR is also improved to 1.1. The designed antenna is well suited for IEEE 802.11a WLAN and many short range applications.

References

- [1] Constantine A. Balanis, "Antenna Theory Analysis and Design", 3rd edition A John Wiley & Sons, INC., 2005.
- [2] Girish Kumar, K.P.Ray, "Broadband Microstrip Antennas ", 2003 Artech House, INC. 685 Canton Street Norwood, MA 02062.
- [3] Ajay kumar, Dwejendra Arya, D.K. Srivastava, "Band Width of Microstrip Antenna Improved by using Mushroom type EBG Structure", IEEE 2013 IMPACT.
- [4] FAN YANG, YAHYA RAHMAT-SAMII, "Electromagnetic Band Gap Structures in Antenna Engineering", Published in the United States of America by Cambridge University Press, New York 2009.
- [5] Ruchika Gupta, Mithilesh Kumar, "Bandwidth Enhancement of Microstrip Patch Antennas by Implementing Electromagnetic Bandgap (EBG) Structures", 2012 Fourth ICCICN, IEEE. page no. 15-18.
- [6] N. Engheta, and R.W. Ziolkowski, "Metamaterials, Physics and Engineering Explorations", IEEE Press, 2006.
- [7] R.B. Samii, and H. Mosallaei, "Electromagnetic Band-Gap Structures: Classification, Characterization and Applications", Proceedings of IEEE AP symposium, 2. 560-564, 2001.
- [8] R. G. P. De Maagt, J. C. Vardaxoglou, and J. M. Baracco, "Photonic Bandgap Antennas and Components for Microwave and (Sub) millimetre wave Applications," Special issue on Metamaterials, IEEE Trans. on Antennas and Propagation, vol. 51, pp. 2667-2677, 2003.
- [9] Jing Liang and Hung-Yu David Yang, "Radiation Characteristics of a Microstrip Patch Over an Electromagnetic Bandgap Surface", IEEE TRANSACTIONS ON ANTENNAS AND PROPAGATION, VOL. 55, NO. 6, JUNE 2007.
- [10] L. Leger, T. Monediere, and B. Jecko, "Enhancement of Gain and Radiation Bandwidth for a Planar 1-D EBG Antenna," Mic. and Wireless Comp. Lett., IEEE, Vol. 15, No. 9, p. p. 573- 575, September 2005.
- [11] D. Pozar, "Input impedance and mutual coupling of rectangular microstrip antennas," IEEE Trans. Antennas Propag., vol. 30, pp. 1191-1196, Nov. 1982.

- [12] F. Yang and Y. Rahmat-Samii, "Microstrip antennas integrated with electromagnetic band-gap (EBG) structures: A low mutual coupling design for array applications," *IEEE Trans. Antennas Propag.*, vol. 51, pp. 2936–2946, Oct. 2003.