

Intensity Based Dual Axis Solar Tracking System

K. Maharaja¹, R. Joseph Xavier², L. Jenifer Amla³, P. Pradeep Balaji⁴
*Sri Ramakrishna Institute of Technology,
Coimbatore, Tamilnadu, India.*
*maharajasrit@gmail.com¹, principal@srit.org², jeniferamla.l@gmail.com³,
pradeepbalaji.eee@srit.org⁴*

Abstract

Solar energy is a viable source on a broad scale. The electric power generated by a photovoltaic power generation system can be used for wide range of applications. Solar Tracking System is the most appropriate technology to enhance the efficiency of the solar cells by tracking the sun. This paper presents the hardware design and implementation of a system that ensures the position of the solar panel to be always normal to the incident solar radiation in order to extract maximum energy falling on it. Experimental results show that the intensity based dual axis tracking system improves the overall efficiency.

Keywords: Solar Energy; Tracking System; Maximum Energy; Dual Axis System

Introduction

Energy is the prime factor for the development of a nation. An enormous amount of energy is extracted, distributed, converted and consumed in global society daily. In recent years, the need for energy is increasing many folds, while the reserves of conventional energy are getting depleted at a rapid pace. The resources of fossil fuels are limited and their use results in global warming due to emission of green house gases. To provide a sustainable power production and a non-polluted world in future, there is a growing demand for energy from renewable sources like solar, wind, hydrothermal and tidal waves. India is rich in renewable sources to overcome its demand. The renewable energy potential of India is 87,200MW [1]-[2]. In total potential of renewable energy, solar power has the maximum percentage. About 5,000 trillion kWh per year energy is incident over India's land area with most parts receiving 4-7kWh per sq.m per day [3].

Solar tracker is an automated solar panel that actually follows the sun to increase the power. Solar panels are mainly made by semiconductor materials. Si which is the

major component of manufacturing solar panel, has an efficiency of 24.5% [4]. Unless high efficient solar panels are used, the only way to enhance the performance is by increasing the intensity of light falling on it. Solar trackers are the most appropriate and proven technology that increases the efficiency of the solar panel by keeping the panels always aligned with the sun. The two types of solar tracking systems are Single axis tracking system and Dual axis tracking system [5]. Even though technology for trapping solar energy is already in existence, the process proposed is used to increase the overall efficiency of the system. In this paper, Light Dependent Resistors are used as sensors of the solar tracker. The designed tracker has a precise control mechanism. The design and implementation methodology of a small prototype of dual axis solar tracking system is presented.

Solar Tracking System

Development of solar panel tracking system has been ongoing for several years. Conventional solar panel, tilted and rigidly fixed at a certain angle, limits their area of exposure to the sun during the entire course of the day. Therefore, the average solar energy is not maximized. Solar tracking systems are essential for solar energy based power generation systems as the sun moves across the sky, it is essential to have the solar panel track the location of the sun, so that the panels are always aligned right angle to the sun. Solar panels in the market are costlier. In order to increase the power, more solar panels are required. Hence, this method provides an effective solution rather than purchasing additional solar panels. In this paper an efficient tracking system is designed to increase the overall efficiency of the system.

A. Single Axis Tracking System

Various ways have been experimented for tracking the sun. One of these methods is single axis tracking system. Single Axis Sun Tracking Solar System has one degree of freedom that acts as an axis of rotation. The axis of rotation of single axis tracker is typically aligned along a true North meridian. It is possible to align them in any cardinal direction with advanced tracking algorithms. This model is able to track and follow the Sun intensity in order to get maximum power at the output regardless motor speed. The system can be applied in the residential area for alternative electricity generation especially for non-critical and low power appliances.

B. Dual Axis Tracking System

The dual axis solar trackers have two degrees of freedom that acts as axes of rotation. These axes are typically normal to one another. The tracker senses the direct solar radiation falling on photo-sensors as a feedback signal to ensure that the PV panel is tracking the sun all the time. Dual axis trackers allow for optimum solar energy levels due to their ability to follow the sun vertically and horizontally. They are typically used in smaller residential installations and locations with very high government feed in tariffs.

Proposed System And Description

This paper shows the hardware implementation and its experimental results that validate the proper operation of the proposed system. Two-axis tracking system changes both azimuth (horizontal) and altitude (vertical) degrees of solar panel. The schematic block diagram of the proposed solar tracker is shown in Fig. 1.

Four Light Dependent Resistors (LDR) as a light sensor have been used. It is named as LDR-U for upper side, LDR-D for lower side, LDR-L for left side and LDR-R for right side. The light sensors are separated by divider which will create shadow on one side of the light sensor if the solar panel is not perpendicular to the sun. For the controlling circuit, microcontroller 16F877A acts as a brain that controls the movement of the motor via relay. Data received from the sensors is processed by the microcontroller (PIC16F877A). The microcontroller will send data to the two Bi-directional DC-g geared motors via relay to ensure solar panel is perpendicular towards the Sun. Relay controls the rotation of the motors either to rotate clockwise or anticlockwise. The solar panel that is attached to the motors will react according to the direction of the motor. If the LDR-U value is low compared with LDR-D, the Motor-1 will rotate in forward direction otherwise it will rotate in reverse direction. If LDR-L value is low when compared with LDR-R, the Motor-2 will rotate in forward direction otherwise it will rotate in reverse direction. Thus the solar panel will automatically track towards the sun's maximum intensity in both the axis throughout the day.

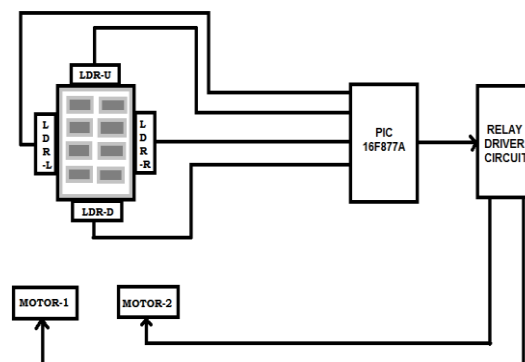

Figure 1: Block Diagram

C.Sensor Unit

A sensor is a device that measures a physical quantity and converts it into a signal which can be read by an observer or by an instrument. The sun's position is required to be sensed continuously. The presence of the solar panel is required to be sensed at the extreme ends. The light dependent resistors are used in the circuit to sense the change in the sun's position. A photo resistor or light dependent resistor or cadmium sulphide (CdS) cell is a resistor whose resistance decreases with increasing incident light intensity. A photo resistor requires a power source because it does not generate photocurrent; a photo effect is manifested by change in the material's electrical resistance. Cadmium sulphide (CdS) photo resistor is used in the designed prototype.

To utilize the photo resistor, it is placed in series with another resistor. A voltage divider is thus formed at the junction between photo resistor and another resistor; the output is taken at the junction point to pass the measured voltage as input to the microcontroller. The sensors are used for tracking both azimuth and altitude angle. Fig. 2 shows the shadow arrangement of the LDR.

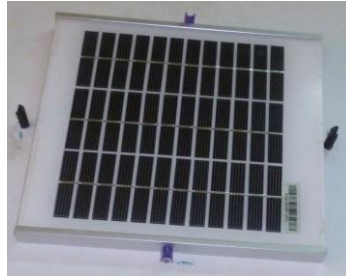

Figure 2: Shadow Arrangement

D. DC Geared Motor

The motor chosen for the proposed system is a DC motor with geared arrangement, because it is cheaper than stepper and servo motors. It is used to achieve desired speed in moving the panel according to sun's position. 12V DC geared motors are used for this application. The most important effect of using DC motor with geared arrangement in dual axis tracker system is to get mechanical stability of PV panel without spending much power for DC motors. When the panel is not desired to move, the DC motors are not driven and the PV panel is kept in stable position due to mechanical lock mechanism in the gear system of DC motors. So the electrical efficiency of the solar panel has also been increased in this manner. The control circuit is powered by a 12V battery and this battery is charged by the PV panel. Thus, the tracker system does not need any external power supply. The Specifications of geared motor is given in Table I.

Table 1: Gear Motor Specifications

S. No	Parameters	Rating
1	Voltage	12V
2	Power	18W
3	Speed	30 RPM
4	Insulation Type	Class B

E. Control Unit

Fig. 3. shows the flowchart of PIC16F877A program. This microcontroller has been used in proposed system. Microcontroller is the heart of overall system. PIC microcontroller is the first RISC based microcontroller fabricated in CMOS

(Complementary Metal Oxide Semiconductor) that uses separate bus for instruction and data allowing simultaneous access of program and data memory.

The main advantage of CMOS and RISC combination is low power consumption resulting in a very small chip size with a small pin count [6]. The main advantage of CMOS is that it is immune to noise than other fabrication techniques [7]. PIC16F877A analyzes the data and generates a logic signal to drive the DC motor 1 to turn back the PV panel to its initial position. The initial position of the PV panel is parallel to horizontal plane. Putting the PV panel into its initial position prevents it turning back to sun's rays in the morning.

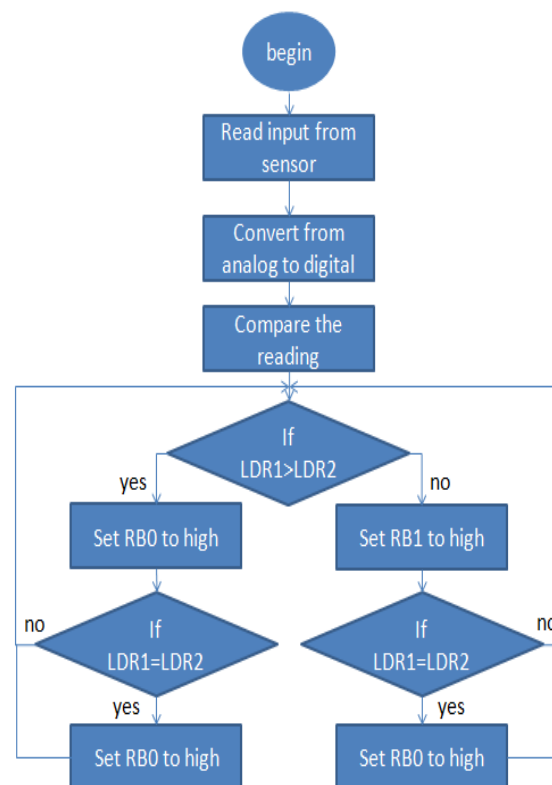

Figure 3: Flowchart of PIC16F877A Program

F. Driver Circuit

12V DC geared motors are used for this application. These motors greatly reduce the complexity and cost of designing and constructing power tools, machines and appliances calling for high torque at relatively low shaft speed or RPM. Gear motors allow the use of economical low-horsepower motors to provide great motive force at low speed such as in lifts, winches, medical tables, jacks and robotics. Driver circuit for the proposed technique is shown in Fig.4. 12V is applied across the transistor through a resistor to limit the current. Four transistors are used to control the operation of two motors. The output pulse from the PIC Controller is given to the base

of the transistor through a resistor to switch ON/OFF the transistor. The output voltage across the collector-emitter is connected to the relay.

The motor terminals are connected across two relays to drive the motor in both forward and reverse direction. When the supply is switched ON, 12 volts is applied to the transistor circuit. If the output pulse from the PIC controller is HIGH, then the transistor is switched ON. The voltage given to the relay is reduced to zero. Due to this change in voltage the moving contact changes its position. Similarly, if the output pulse from the PIC controller is LOW, then the transistor is switched OFF and the relay is activated accordingly. From this control operation, the motor-1 and motor-2 will be operated in both forward and reverse direction.

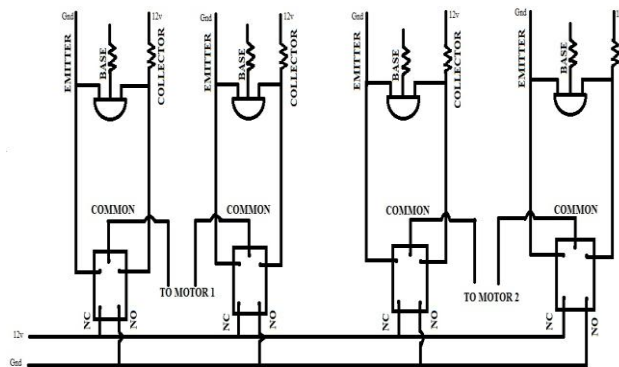

Figure 4: Driver Circuit

Hardware Implementation and Results

The complete mechanical structure of the proposed dual axis solar tracker is illustrated in Fig.5.

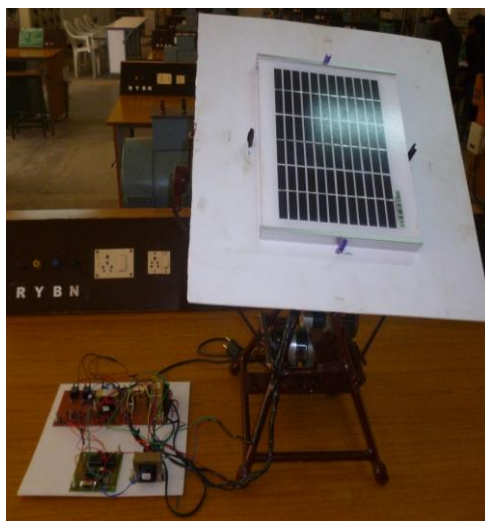

Figure 5: Mechanical Structure of Dual Axis Tracking System

Aluminum has been used in body of the tracker since it is light and pretty strong metal to hold up the weight of PV panel. The solar panel is fixed in a frame which is attached to the rotatable shaft. When the motor is ON, the shaft rotates thereby making the solar panel move. The frame is attached to the motor shaft through chain arrangement. Due to low cost and low power consumption DC geared motor is used. The motor is fixed with the help of coupling arrangement which is shown in Fig.5. Two motors are used for dual axis mechanism [8]-[10]. One motor is used for tracking the solar panel in one axis from north to south and another motor is used for tracking the solar panel in another axis from east to west. The rotary motion of the motor is given to chain drive from which the coupling is used to move the solar panel accordingly. The simple mechanical structure is aimed with this design.

G. Test Performance of Solar Panel without Tracking System

The Solar panel is kept in the fixed position and the performance of the solar panel is tested from morning to evening. The rating of the solar panel is 12 volts, 5 watts. A rheostat load of 30 ohm is connected across the solar panel, the voltage and current are measured using voltmeter and ammeter respectively. The readings of voltage and current are noted every one hour.

H. Test Performance of Solar Panel with Tracking System

The Solar panel is placed outdoor along with the tracking system and the performance of the solar panel is tested from morning till evening. The rating of the solar panel is 12 volts, 5 watts. A rheostat load of 30 ohm is connected across the solar panel, the voltage and current are measured using voltmeter and ammeter respectively. The readings of voltage and current are noted every one hour and tabulated. The comparative results of the performance of solar panel with and without tracking system are shown in Table II. The performance curve is shown in Fig.7.

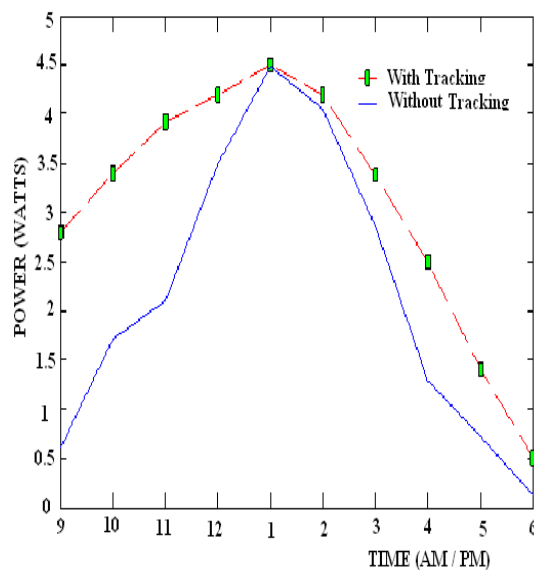

Figure 7: Performance of Solar Panel With Tracking

Table 2: Performance Comparison of Solar Panel Without And With Tracking

Time (Hrs)	Without Tracking			With Tracking		
	Voltage (V)	Current (A)	Power (W)	Voltage (V)	Current (A)	Power (W)
9 am	5.5	0.11	0.605	12.2	0.23	2.8
10 am	9	0.19	1.71	13.5	0.25	3.4
11 am	10.5	0.2	2.1	14	0.28	3.92
12 pm	12.5	0.28	3.5	14	0.3	4.2
1 pm	14	0.32	4.49	15	0.3	4.5
2 pm	13.5	0.3	4.05	14	0.3	4.2
3 pm	11	0.26	2.86	13	0.26	3.38
4 pm	8	0.16	1.28	10	0.25	2.5
5 pm	6	0.12	0.72	7	0.2	1.4
6 pm	2.5	0.05	0.125	5	0.1	0.5

Average power obtained from solar panel without tracking is 2.144 watts; Average power obtained from solar panel with tracking is 3.08 watts. The improved efficiency is 43.65% neglecting the power consumption of DC motor. It is observed that the proposed dual axis tracking system presents a efficient system to harness solar energy which ensures more energy conversion than the existing fixed orientation of solar module system.

Conclusion

In this paper, the hardware of the dual axis solar tracking system design and implementation has been proposed. This system increases the efficiency of the solar panel. It is completely automatic and ensures minimum maintenance at low cost. Since, it is a dual axis system maximum efficiency can be obtained over a period of time. The installation and implementation of dual axis tracking system can be placed anywhere as it does not depends on climatic conditions etc. It can be used in many applications such as automobiles, residential areas, industries, institutions etc. In order to place more number of panels, the systems have to be designed with more mechanical strength. The power consumption of the system can be reduced by improving the system design.

Acknowledgment

The authors would like to thank SNR Sons Charitable Trust and Sri Ramakrishna Institute of Technology for their support and encouragement. We would like to thank Mr. M. Aravindh, Mr. S.Hari Prasad, Mr. M. Mathan and Mr. P. Selvakumar for their valuable contribution in completion of the project.

References

- [1] S.Chakma, R.C.Vaishya, A.K. Yadav and P.Pooja, "Assessment of Renewable Energy Potential in India: A Review" International Conference and Utility Exhibition Power and Energy Systems: Issues & Prospects for Asia, Pattaya City, pp. 1-7, Sept. 2011.
- [2] T.M.Razykov, C.S.Ferekides and D.Morel, "Solar Photovoltaic Electricity: Current Status and Future Prospects", Elsevier International Journal on Solar Energy, Vol.85, Issue 8, pp. 1580-1608, Aug. 2011.
- [3] A.Anantha and P.L. Chowhan, "Strategies for Nation-wide Survey of Renewable Energy Sources Available in Each Village in India", Proceeding of the Intersociety on Energy Conversion Engineering Conference, Honolulu, HI, Vol. 3, Aug. 1997.
- [4] A.Chauhan and R.P.Saini, "Renewable Energy Based Power Generation for Stand-alone Application: A Review", IEEE International Conference on Energy Efficient Technologies for Sustainability, Nagercoil, pp. 424-428, Apr. 2013.
- [5] C. Alexandru and C. Pozna, "Different tracking strategies for optimizing the energetic efficiency of a photovoltaic system", IEEE International Conference on Automation, Quality and Testing, Robotics, Cluj-Napoca, vol. 3, pp. 434-439, May 2008.
- [6] A.Stjepanovic, S.Stjepanovic, F.Softic and Z.Bundalo, "Microcontroller Based Solar Tracking System", International IEEE Conference of Telecommunication in Modern Satellite, Cable and Broadcasting Service, Nis, pp. 518-521, Oct. 2009.
- [7] A.Kassem and M.Hamad, "A Microcontroller Based Multi-function Solar Tracking System", IEEE International Systems Conference, Montreal, QC, pp. 13-16, Apr. 2011.
- [8] Catalin Alexandru "The Design and Optimization of a Photovoltaic Tracking Mechanism", IEEE International Conference on Power Engineering, Energy and Electrical Drives, Lisbon, pp. 436-441, Mar. 2009.
- [9] Prabodh Bajpai and Subhash Kumar "Design, Development and Performance Test of an Automatic Two-Axis Solar Tracker System", Annual IEEE Conference on India Conference, Hyderabad, pp. 1-6, Dec. 2011.
- [10] M.T.A.Khan, S.M.S.Tanzil, R.Rahman and S.M.S.Allam, "Design and Construction of a Solar Tracking System", International IEEE Conference on Electrical and Computer Engineering, Dhaka, pp. 326-329, Dec. 2010.

