

## Simulation Investigations on Flywheel Energy Ride Through Systems

Sooraj Narayan A, Dr. Mohd. Z. A. Ansari  
Ghousia college of engineering VTU, Belguam

### ABSTRACT

*Nowadays static UPS systems are preferred for low-power applications, although rotary UPS systems offer some interesting advantages. The rotary UPS now having only high end applications and is not available for, hospitals-critical loads like operation theatre and ICU's, utility, small collocations, military applications- data centers , telephone equipments - mobile towers, storage devices and various data centers. In this paper, simulation investigations for a diesel rotary UPS system have been carried out using MATLAB / SIMULINK for possible implementation of this system to feed the critical loads as described above uninterruptedly. A rotary UPS uses the inertia of a high-mass spinning Flywheel (Flywheel energy storage) to provide short-term ride-through the time of power loss. The Flywheel also act as a buffer against power spikes and sags, since such short-term power events are not able to appreciably affect the rotational speed of the high-mass Flywheel, Flywheel-based UPS systems typically provide 10 to 20 seconds of protection before the Flywheel has slowed and power output stops. The name Flywheel energy ride through came from the operation of Flywheel in the rotary UPS. Flywheel is the kernel of the system described above.*

*Index Terms— Diesel rotary UPS, Flywheel energy storage, Kinetic Energy, rotary UPS.*

### I. INTRODUCTION

The need for continuous power supply increasing day by day. Critical loads are in need of continuous power, there shouldn't be any break. [2][9][10] However, the nature of the problem varies rapidly. In some cases, large scale power demands need only in short term ride through and stabilization. In other cases, low power applications for large time ride through, or, aggressive industrial loads need UPS with high peak handling or large site distribution at medium voltage. Major function of Uninterruptible Power Supplies (UPS) is to assure power security, whose sole purpose in life is to provide continuity and quality of power at all times. Uninterruptible power supply (UPS) is also known as uninterruptible power source or battery/Flywheel backup. It is an electrical apparatus that supply emergency power to a load when power interruption occurs. From the stored batteries or from Flywheel UPS supplies power and it differs from an auxiliary or an emergency power system or standby generator. [6] Nowadays static UPS systems are preferred for low-power applications, although rotary UPS systems offer some interesting advantages. [5] A **rotary UPS** uses the inertia of a high-mass spinning Flywheel (Flywheel energy storage) to provide short-term ride- through the time of

power loss. The Flywheel also act as a buffer against power spikes and sags, since such short-term power events are not able to appreciably affect the rotational speed of the high-mass Flywheel, Flywheel-based UPS systems typically provide 10 to 20 seconds of protection before the Flywheel has slowed and power output stops. [3]. An important task for the Flywheel design is to determine power and energy storage requirements and the location of the storage device [13]. In this paper simulation investigation relating to static UPS and rotary UPS system is discussed with eddy current coupling and Flywheel model and the results have been reported.

### II. SIMULATION MODELING

#### A. Static UPS simulation

Simulation model of 63 KVA static UPS system is shown in Fig. 1. Three phase input is given to the rectifier and the capacitor acts a battery or energy storage here. The capacitor discharges and is inverted by the inverter and load has supplied by it. The rectifier and inverter circuit has major subsystems in the simulation part.

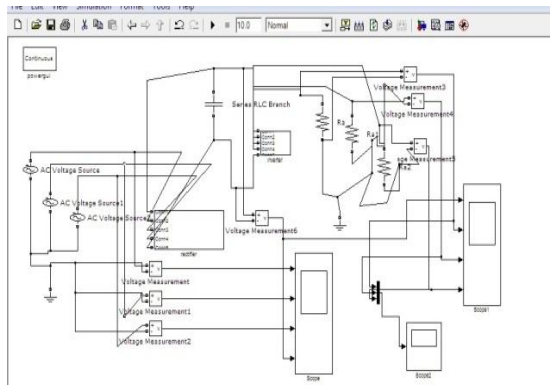

Fig 1: Simulation model of static UPS

**B. Rotary UPS simulation**

*i. Simulation without Flywheel*

Simulation model of 63 KVA Rotary UPS system without Flywheel is shown in Fig. 2. The observations made are as follows:

The main is supplying continuous power to the load. It fails at 7<sup>th</sup> second. Failure of power supply is sensed through sensors and issues a command to the diesel engine to start at 12<sup>th</sup> second and the power to the load is restored. There was an interruption of power for 5 seconds which is not acceptable for critical loads.

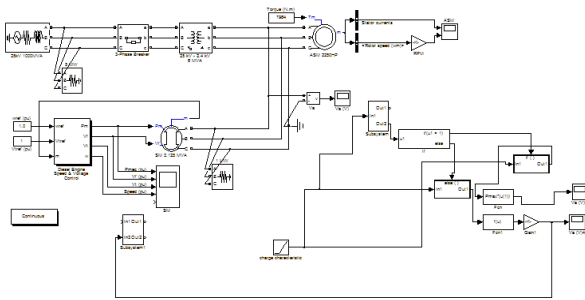

Fig 2: simulation model of rotary UPS without Flywheel

*ii. Simulation with Flywheel*

Simulation model of rotary UPS with Flywheel is shown in Fig. 3. Once the mains fails at say 7<sup>th</sup> second, energy stored in the Flywheel is transferred to the alternator and thereby to the critical loads and discharging of the Flywheel occurs. The diesel engine gets the command to start at 12<sup>th</sup> second and the power to the load is then restored. Time between failure and restoration, Flywheel was supplying the critical loads.

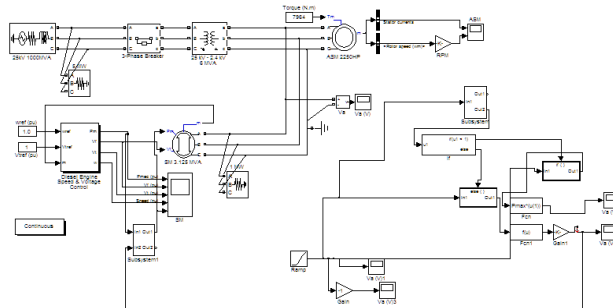

Fig. 3: Simulation model of rotary UPS with Flywheel

### III. RESULTS AND DISCUSSIONS

#### A. Static UPS

Fig. 4 represents three phase output of a static UPS. The green, red and blue waveforms indicate the three different phase voltage wave forms. The output waveform shows continuous distortion. When static UPS is unable to supply exact current, there occur clipping of voltage waveform, hence load distortion occurs (Fig. 4).

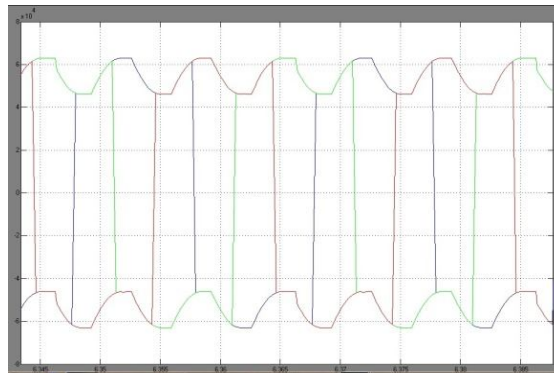

Fig. 4: Three Phase Output Distortion

The harmonics present in the output of static UPS is shown in Fig.5. The total harmonic distortion was obtained by the FFT analysis using SIMULINK.

The THD result obtained is 21.55%, which is quite high. The rectifier at the input to a static UPS converts AC to DC and creates harmonic distortion that will reflect back to the grid supply. Additional expense is required to filter out these kinds of harmonics.

Power capacitors are one of the most unreliable components in electrical design. A static UPS requires capacitors for the correction of power factor, input harmonic distortion and output harmonic distortion suppression. These capacitors are prone to fail which significantly reduces the reliability of a static UPS system.

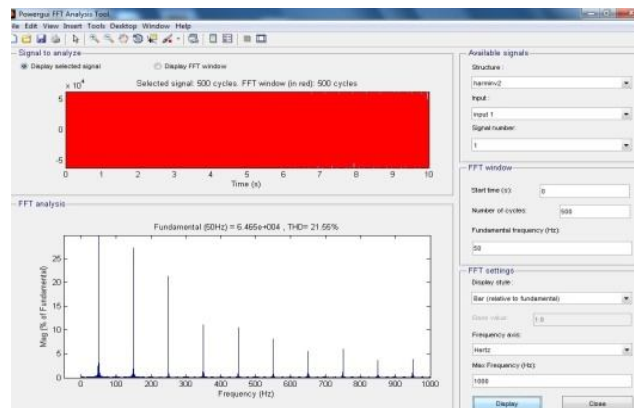

Fig. 5: Total Harmonics in Static UPS

First waveform in Fig. 6 is the input supplied while the last three waveforms represent the load current distortion in static UPS. The rectifier at the input to a static UPS converts AC to DC and creates harmonic distortion that will reflect in the output.

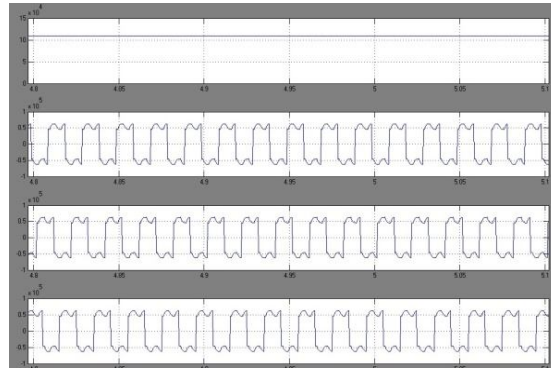

Fig. 6: Load Distortion waveforms

## B. Rotary UPS

### i. Without Flywheel

In this type of operation the system is without connecting the Flywheel, whenever power fails interruption occurs and after few seconds the diesel engine starts, the starting time is the time of interruption and power to the critical loads are not supplied during this period.

The operation of the system is described in section II; the simulation results obtained in Fig. 7 are discussed as follows:

It is observed that whenever power fails (here at 7<sup>th</sup> second) there is no current flow in the circuit, speed decreases to the minimum level, stator current distorts, no supply is provided for the critical loads till the generator starts. Here, from 7<sup>th</sup> to 12<sup>th</sup> second the supply remains zero and no power is supplied to the critical loads. The power interruption occurs and there is no continuity of power in the circuit.

Waveform A represents the mechanical output of the diesel engine, which is zero till 12<sup>th</sup> second and after 12<sup>th</sup> second it increases and stabilizes after few seconds.

The waveforms B and C represents the terminal and field voltages of the diesel engine respectively. Till 12<sup>th</sup> second it is zero and, after 12<sup>th</sup> second, when the diesel engine starts, it goes to its desired value and settles.

Waveform D represents the speed of the machine (load) which is in the power system, the speed decreases to zero after 5 seconds and gradually increasing after the starting of diesel engine.

The last waveform E represents the mechanical power output from the Flywheel. The Flywheel output is always zero in the system since no Flywheel is connected.

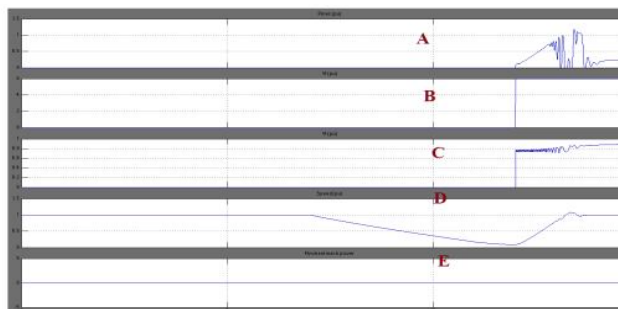

Fig. 7: Simulation result of rotary UPS without using Flywheel

### ii. With Flywheel

In this type of operation the system is connected with the Flywheel, whenever power fails the control is given to the Flywheel and the stored KE is transferred to the alternator and it supplies the critical loads for a small amount of time. By this time diesel engine starts (the power back up) and it supplies the critical loads or the system of loads. The Flywheel will be continuously running and energy is stored in as KE (kinetic energy). This energy is transferred through eddy current coupling to the alternator and to the critical loads.

Fig. 8, shows the results of the system with Flywheel, Here the Flywheel is operated in 7<sup>th</sup> second and operated till the diesel generator restores the power (i.e., 12<sup>th</sup> second) and it provides continuous energy supply to the critical loads.

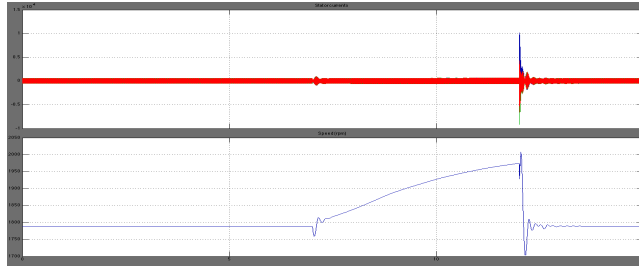

Fig. 8: Simulation Results of rotary UPS with Flywheel

Fig. 9 shows the three phase output of the rotary UPS with Flywheel system. It is observed that there are no distortions in the output and there are no harmonics present in it.

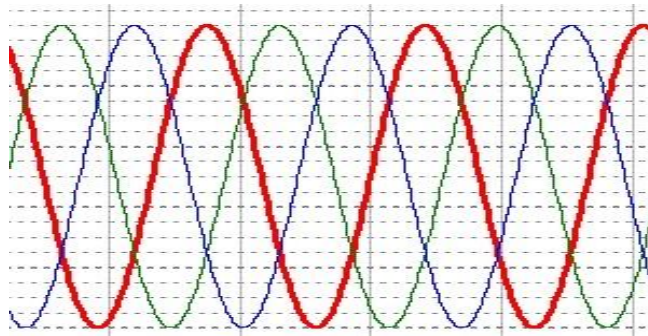

Fig. 9: Three phase output of rotary UPS with Flywheel

#### **IV. CONCLUSIONS**

Flywheel storage systems have been used for a long time. Material and semiconductor development are offering new possibilities and applications previously impossible for Flywheels. The fast rotation of Flywheel rotors is suitable for direct generation of high voltage. Thus for Flywheel applications, the motor/generator part has a large upgrade potential. In this paper design of a rotary UPS is discussed with eddy current coupling and Flywheel simulation model. Flywheels are now a days using only for large power applications. In this paper, we have proposed that it can be used for low power applications as well. Simulation results show that in static UPS there is distortion in load, and there is no continuity. The critical loads always will be suffering from interruption in static UPS system. The use of Flywheel and rotary UPS makes the system uninterrupted, continuous, harmonic less and zero distortion.

#### **ACKNOWLEDGMENT**

The authors Sooraj Narayan A. and Mohd. Z. A. Ansari would like to thank the Principal of Ghouisia College of Engineering and also the authorities of Ghouisia Industrial and Engineering Trust for all the co-operation and encouragement.

#### **REFERENCES**

- [1] W Mervin Burger, Penbro Kelnick “The rotary UPS: an alternative source of electrical power “ , energize-December 2006 .
- [2] R. Arghandeh Jouneghani, , M. Pipattanasomporn, ,and S. Rahman, “Flywheel Energy Storage Systems for Ride-through Applications in a Facility Microgrid” Ieee Transactions On Smart Grid, VOL. 10, NO.10, 2012
- [3] Haichang Liu\*, Jihai Jiang , “ Flywheel energy storage—An upswing technology for energy sustainability “ , School of Mechatronics Engineering, Harbin Institute of Technology, Harbin, Heilongjiang Province, China , science – Elsevier direct .page no 599-600
- [4] T. Loix, E. Haesen, K. De Brabandere, J. Driesen and R. Belmans K.U.Leuven ESAT / ELECTA “Drive Model for a Low-Power Rotary Uninterruptible Power Supply”, 3<sup>rd</sup> IEEE B Enelux Young Researchers Symposium In Electrical Power Engineering 27-28 APRIL 2006, GHENT, B ELGIUM
- [5] Jennifer K. H. Ratner, James B. “composite Flywheel rotor technology – a review”

IEEE Transactions on Smart Grid- 2007

- [6] Allen Windhorn, Member, IEEE. "A Hybrid Static/Rotary UPS System" IEEE Transactions on Industry Applications, VOL. 28, NO. 3, MAY/JUNE 1992
- [7] Florian Herrault, Chang-Hyeon Ji, and Mark G. Allen, IEEE "Ultraminiaturized High-Speed Permanent-Magnet Generators for Milliwatt-Level Power Generation" journal of micro electromechanical systems, vol. 17, no. 6, december 2008
- [8] B J Beck "The Design And Performance Of A Rotary Ups System" Holec Ltd, Leatherhead, Surrey, 2001
- [9] Alexander Kusko and Stephen Fairfax "Survey of Rotary Uninterruptable Power Supplies." Electrical Division Failure Analysis Associates, Inc. Three Cambridge Center Cambridge, MA 02142
- [10] Hansjoacihn Dolezal "Dynamic-Rotary Systems with Flywheel and Diesel Engine" Ad . STR'JVER KG (GMBH & CO' Niendorfer Weg 11 2000 Hamburg 61
- [11] Alexander Kusko and Stephen Fairfax "Survey of Rotary Uninterruptible Power Supplies" , Electrical Division Failure Analysis Associates, Inc. Three Cambridge Center Cambridge, MA 02142
- [12] Simulation of Flywheel energy storage system – Claus R Danielson, Nicolas W. Frank. Conference paper – 2-06-2011
- [13] Flywheel energy storage system for ride through applications in a facility macro grid. R. Arghandeh Jouneghani, M. Pipattanasomporn, S. Rahman, Fellow, IEEE 2012.

**Sooraj Narayan A.** pursuing Master of Technology in Power System Engineering at Ghousia College of Engineering, Visvesvaraya Technological University, Belgaum. He did his Bachelor of Engineering from K.S.R. College of Technology, Anna University Coimbatore in 2011. His field of interest includes Power System Restoration and Artificial Neural Networks.

**Dr. Mohd Z. A. Ansari** received the B. E. , M. Tech. , degrees from Mysore University and PhD degree from JNT University, Hyderabad, India in 1985, 1993 and 2011, respectively.

He is a Professor and Head of the Department of Electrical Engineering at Ghousia College of Engineering, Ramanagaram, India. He has published several research papers in International Journals and Conferences. His research interest include voltage stresses in transformers, power system control and high voltage engineering. Dr. Ansari is a Life member of ISTE, New Delhi, India and member of IEEE, USA.