

Design and Optimization of Flywheel for Automobile Applications

Aswin Inbaraj Jaison A^{1*}, Karuppasamy K²

^{1*} PG Scholar, Department of Mechanical Engineering, Regional Centre of Anna University, Tirunelveli, Tamil Nadu, India.

² Assistant Professor, Department of Mechanical Engineering, Regional Centre of Anna University, Tirunelveli, Tamil Nadu, India.

*Email: aswininbaraj@gmail.com

Mobile: +91-9677915742

Abstract -In this Paper solely focuses on exploring the effects of flywheel geometry on its energy storage / deliver capability per unit mass, further defined as specific energy. In this work, flywheel with various profile such as solid disk, disk rim, webbed/section cut, arm/spoke flywheels are designed. It shows that smart design of flywheel geometry could both have a significant effect on the Specific Energy performance and reduce the operational loads exerted on the shaft/bearings due to reduced mass at high rotational speeds. The efficient flywheel design was used to maximize the inertia of moment for minimum material used and guarantee high reliability and long life. Finite Element analysis is carried out for different cases of loading on the flywheel and maximum von-misses stresses and total deformation are determined.

Keywords: Flywheel, Geometry, Various Material, etc.

1. INTRODUCTION

A flywheel is an inertial energy-storage device. It absorbs mechanical energy and serves as a reservoir, storing energy during the period when the supply of energy is more than the requirement and releases it during the period when the requirement of energy is more than the supply. Focuses on exploring the effects of flywheel geometry on its energy storage/deliver capability per unit mass, further defined as Specific Energy. Proposed computer aided analysis and optimization procedure results show that smart design of flywheel geometry could both have a significant effect on the Specific Energy performance and reduce the operational loads exerted on the shaft/bearings due to reduced mass at high rotational speeds. FE analysis is carried out for different geometry of the flywheel and maximum von misses stresses and total deformations are determined.

1.1 Geometry

It controls the Specific Energy, in other words, kinetic energy storage capability of the flywheel. Any optimization effort of flywheel cross-section may contribute substantial improvements in kinetic energy storage capability thus reducing both

overall shaft/bearing loads and material failure occurrences.

To improve the quality of the product and in order to have safe and reliable design, it is necessary to investigate the stresses induced in the component during working condition.

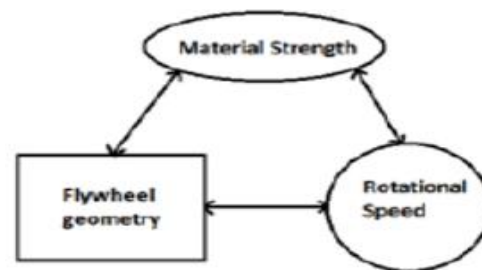

Fig 1 Factors affecting flywheel performance

1.2 Function of flywheel

The main function of a fly wheel is to smoothen out variations in the speed of a shaft caused by torque fluctuations. If the source of the driving torque or load torque is fluctuating in nature, then a flywheel is usually called for. Many machines have load patterns that cause the torque time function to vary over the cycle.

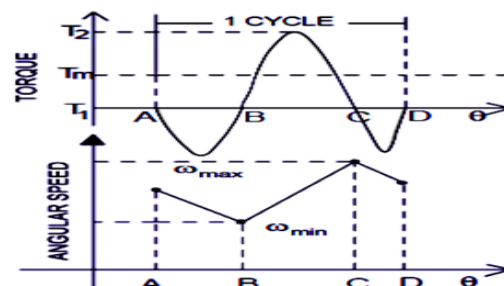

Fig 2 Flywheel function graph

2. Modeling of flywheel

2.1 Design Approach

There are two stages to the design of a flywheel.

1. First, the amount of energy required for the desired degree of smoothening must be found and the (mass) moment of inertia needed to absorb that energy determined.

2. Then flywheel geometry must be defined that caters the required moment of inertia in a reasonably sized package and is safe against failure at the designed speeds of operation.

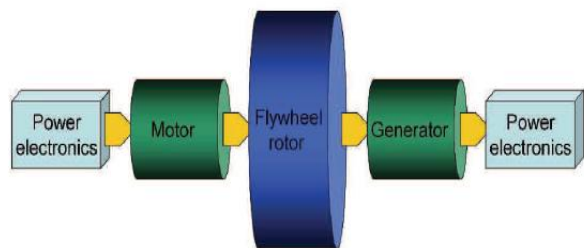

Fig 3 Schematic showing power flow in FES system

2.2 Geometrical Dimension of Flywheel

Flywheel used in the thresher machine is solid disk. Dimensions of flywheel are provided below. this flywheel is designed and analyzed.

- Mass of flywheel (m)=60kg.
- Outer diameter of flywheel(do)=500mm.
- Inner diameter of flywheel(di)=50mm.
- Speed (n)=750 Rpm.

2.3 Materials Used

- S GLASS EPOXY
- CAST IRON

2.4 Material Properties :

Table 1 Mechanical Properties

| Material | Ultimate Stress (Mpa) | Density (Kg/M ³) | Poissons Ratio |
|---------------|-----------------------|------------------------------|----------------|
| Cast Iron | 214 | 7510 | 0.23 |
| S-Glass-Epoxy | 4800 | 2000 | 0.25 |

2.5 Geometry of Flywheel

The geometry of a flywheel may be as simple as a cylindrical disc of solid material, or may be of spoke construction like conventional wheels with a hub and rim connected by spokes or arms. Small fly wheels are solid discs of hollow circular cross section. As the energy requirements and size of the flywheel increases the geometry changes to disc of central hub and peripheral rim connected by webs and to hollow wheels with multiple arms. Mass at largest radius contributes much more since the mass moment of inertia is proportional to mr^2

2.6 Other Flywheel Geometries

Other flywheel geometries taken under study are rim disk, webbed/ section cut, arm/spoke type .keeping mass constant as 60 kg and outside diameter 500 mm, stored kinetic energy is calculated for these profiles

This paper clearly depicts the importance of flywheel geometry design selection and its contribution in the energy storage performance. Although this improvement is to be thought small, it still could be crucial for mission critical operations .other profiles of flywheel given below are designed and analyzed.

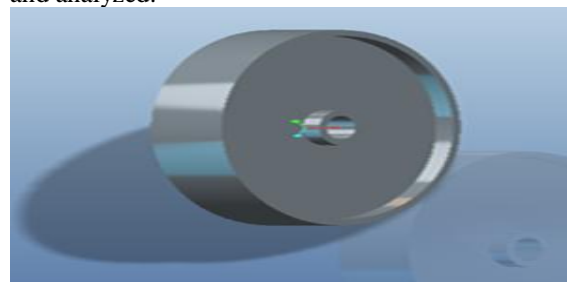

Fig 4 3D model of Rim Type Flywheel

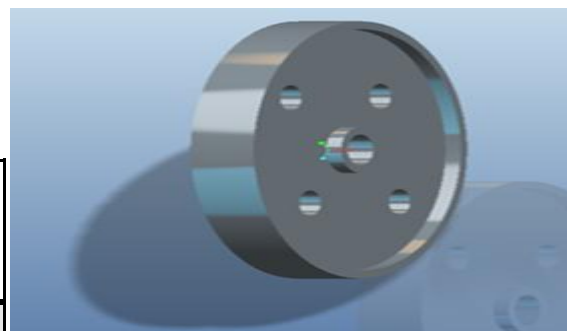

Fig 5 3D model of Cut Type Flywheel

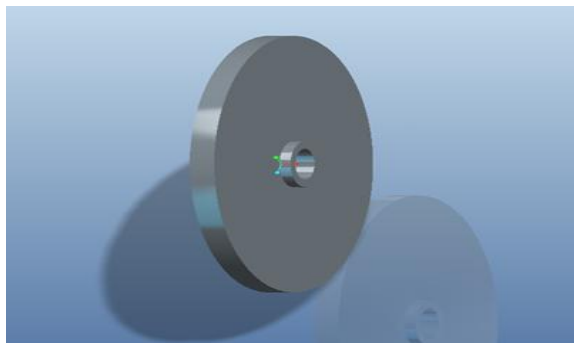

Fig 6 3D model of Solid Type Flywheel

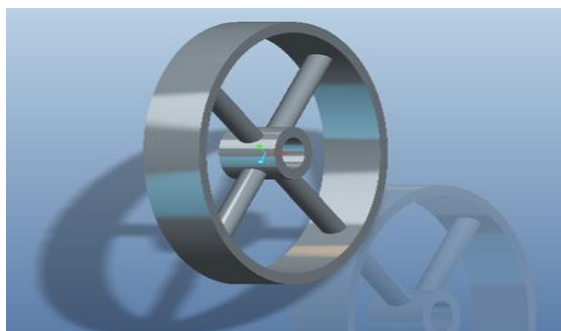

Fig 7 3D model of Spoke Type Flywheel

3. Finite element analysis of flywheel

3.1 Finite Element Analysis

There are generally two types of analysis that are used in industry: 2-D modeling, and 3-D modeling. While 2-D modeling conserves simplicity and allows the analysis to be run on a relatively normal computer, it tends to yield less accurate results. 3-D modeling, however, produces more accurate results while sacrificing the ability to run on all but the fastest computers effectively. The ANSYS CAE (Computer-Aided Engineering) software program was used in conjunction with 3-D CAD (Computer-Aided Design) solid geometry to simulate the behavior of mechanical bodies under thermal/structural loading conditions.

3.1.1 Element Type

Based on the consideration of rotational deformations in the flywheel, the element Solid72, a 3-D 4-node tetrahedral structural solid with rotations, is used to model meshes. The element is defined by 4-nodes with 6DOFs at each node and well suitable to create irregular meshes. It also has stress stiffening capability.

3.2 Meshing Method

Free mesh with smart element sizing is adopted to automatically and flexibly mesh the model. Compared to mapped mesh, which is restricted to only quadrilateral (area) or only hexahedron (volume) elements; free mesh has no

restrictions in terms of element shapes. Smart sizing gives the mesher a greater opportunity to create reasonably shaped element during automatic element generation.

3.3 Meshed Flywheel Model

Various Solid model are designed on the CATIA software. And then they are imported into ANSYS for further analysis. Meshed flywheel model of various types are to be considered and then they are imported into ANSYS. Meshing is carried out generally based on the fine meshing of the solid model.

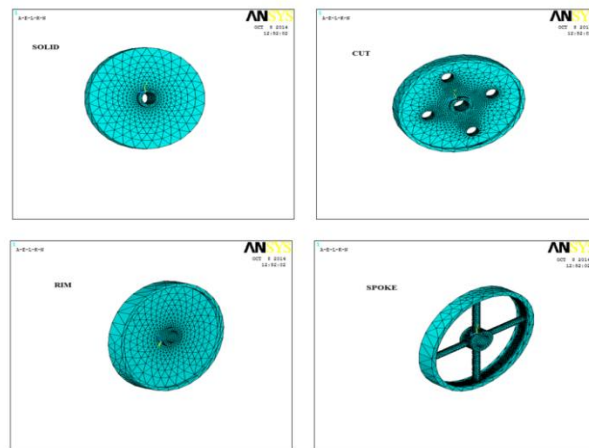

Fig 8 Meshed Flywheel Model

3.4 Solid Type Fly Wheel

3.4.1 Material: Cast Iron

Below Fig 12 represent displacement of Solid Type Fly Wheel- Cast Iron which has the deformed and un-deformed shape of the flywheel analysis. value of deformation is 0.001226mm.

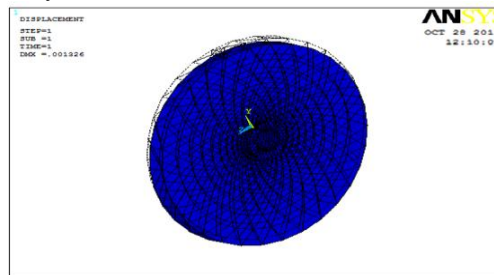

Fig 9 Displacement of Solid Type Fly Wheel- Cast Iron

Fig 13 shows numerical investigation of cast iron- solid type flywheel, which represents the maximum stress developed in the flywheel. The von-mises stress of flywheel is $.156 \times 10^8 \text{ Pa}$ is observed in the following figure.

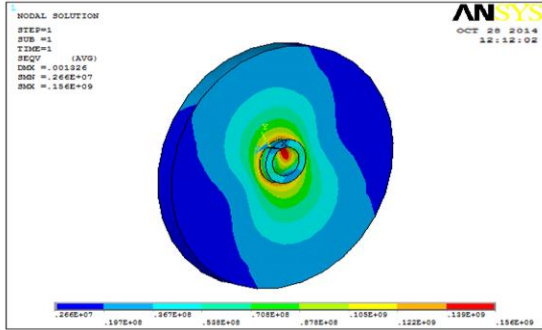

Fig 10 Nodal solution of Solid Type Fly Wheel- Cast Iron

3.4.2 Material: S Glass Epoxy

Below Fig 14 represent displacement of Solid Type Fly Wheel- S Glass Epoxy which has the deformed and un-deformed shape of the flywheel analysis. value of deformation is 0.00247mm.

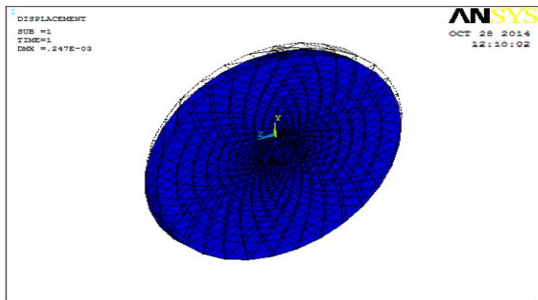

Fig 11 Displacement of Solid Type Fly Wheel- S Glass Epoxy

Fig 15 shows numerical investigation of S Glass Epoxy - solid type flywheel, which represents the maximum stress developed in the flywheel. The von-mises stress of flywheel is 0.291×10^8 Pa is observed in the following figure.

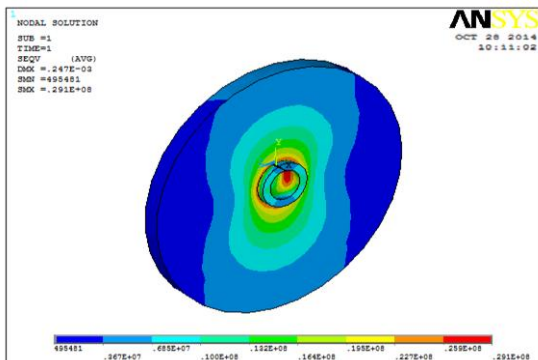

Fig 12 Nodal solution of Solid Type Fly Wheel- S Glass Epoxy

3.5 Cut Type Fly Wheel

3.5.1 Material: Cast Iron

Below Fig 16 represent displacement of Cut Type Fly Wheel - Cast Iron which has the deformed and un-deformed shape of the flywheel analysis. value of deformation is 0.001541mm.

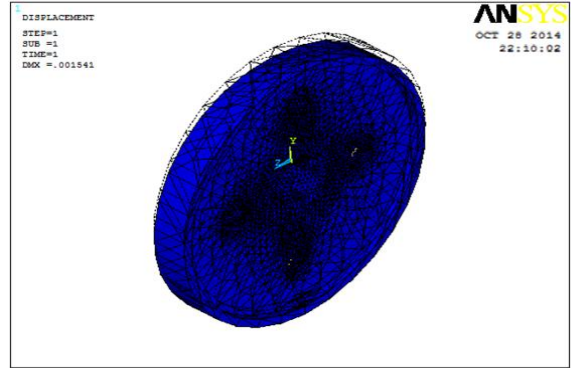

Fig 13 Displacement of Cut type Flywheel-Cast Iron

Fig 17 shows numerical investigation of Cut Type Fly Wheel - Cast Iron, which represents the maximum stress developed in the flywheel. The von-mises stress of flywheel is 0.181×10^9 Pa is observed in the following figure.

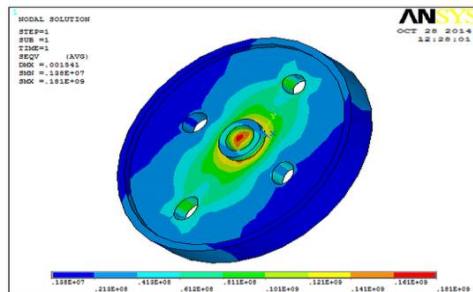

Fig 14 Nodal solution of Cut Type Fly Wheel- Cast Iron

3.5.2 Material: S Glass Epoxy

Below Fig 18 represent displacement of Cut Type Fly Wheel - S Glass Epoxy which has the deformed and un-deformed shape of the flywheel analysis. value of deformation is 0.00287mm.

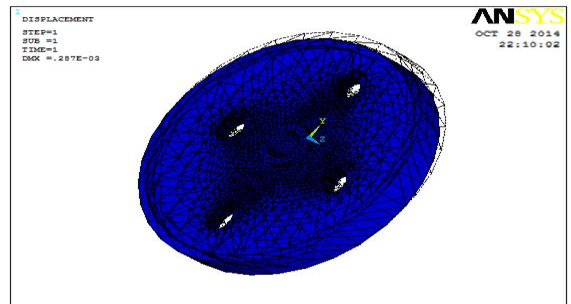

Fig 15 Displacement of Cut type Flywheel- S Glass Epoxy

Fig 19 shows numerical investigation of Cut Type Fly Wheel - S Glass Epoxy, which represents the maximum stress developed in the flywheel. The von-mises stress of flywheel is 0.337×10^8 Pa is observed in the following figure.

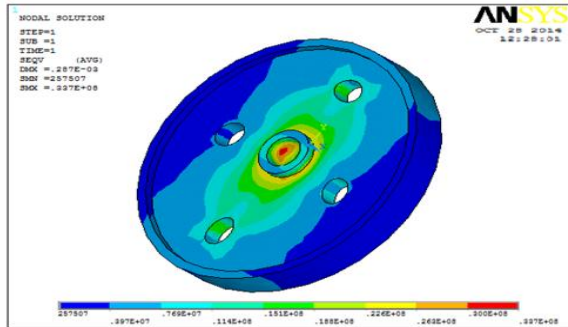

Fig 16 Nodal Solution of Cut type Flywheel-S Glass Epoxy

3.6 Rim Type Fly Wheel

3.6.1 Material: Cast Iron

Below Fig 20 represent displacement of Rim Type Fly Wheel - Cast Iron which has the deformed and un-deformed shape of the flywheel analysis. value of deformation is 0.006058mm.

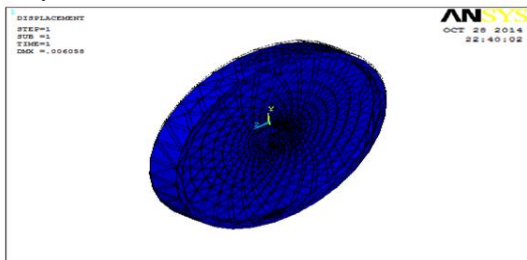

Fig 17 Displacement of Rim type Flywheel- Cast Iron

Fig 21 shows numerical investigation of Rim Type Fly Wheel - Cast Iron , which represents the maximum stress developed in the flywheel. The von-mises stress of flywheel is 0.366×10^9 Pa is observed in the following figure.

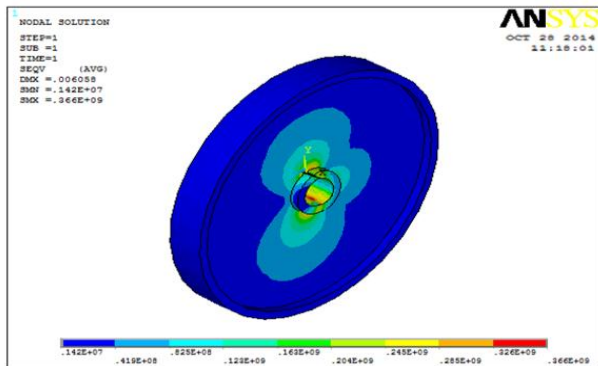

Fig 18 Nodal Solution of Rim type Flywheel- Cast Iron

3.6.2 Material: S Glass Epoxy

Below Fig 22 represent displacement of Rim type Flywheel - S Glass Epoxy which has the deformed and un-deformed shape of the flywheel analysis. value of deformation is 0.001125mm.

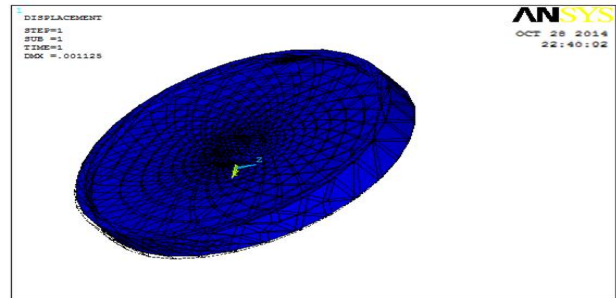

Fig 19 Displacement of Rim type Flywheel- S Glass Epoxy

Fig 23 shows numerical investigation of Rim type Flywheel- S Glass Epoxy, which represents the maximum stress developed in the flywheel. The von-mises stress of flywheel is 0.682×10^8 Pa is observed in the following figure.

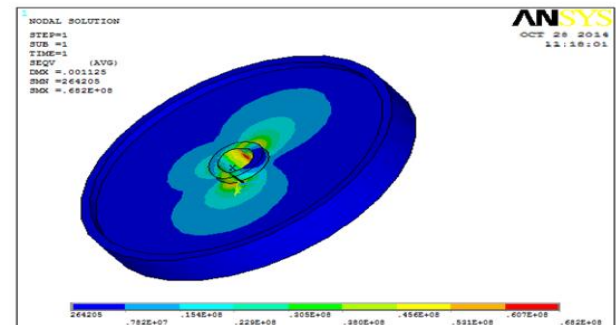

Fig 20 Nodal Solution of Rim type Flywheel-S Glass Epoxy

3.7 Spoke Type Fly Wheel

3.7.1 Material: Cast Iron

Below Fig 24 represent displacement of Spoke Type Fly Wheel - Cast Iron which has the deformed and un-deformed shape of the flywheel analysis. value of deformation is 0.016528mm.

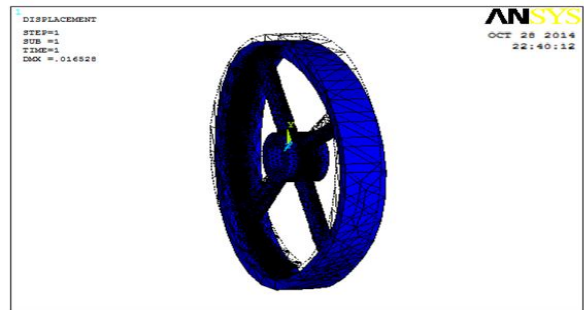

Fig 21 Displacement of Spoke type Flywheel- Cast Iron

Fig 25 shows numerical investigation of Spoke type Flywheel- Cast Iron, which represents the maximum stress developed in the flywheel. The von-mises stress of flywheel is 0.557×10^9 Pa is observed in the following figure.

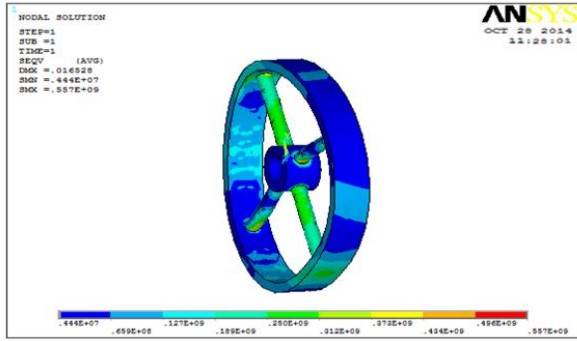

Fig 22 Nodal Solution of Spoke type Flywheel-S Cast Iron

3.7.2 Material: S Glass Epoxy

Below Fig 26 represent displacement of Spoke type Flywheel- S Glass Epoxy which has the deformed and un-deformed shape of the flywheel analysis. value of deformation is 0.00321mm.

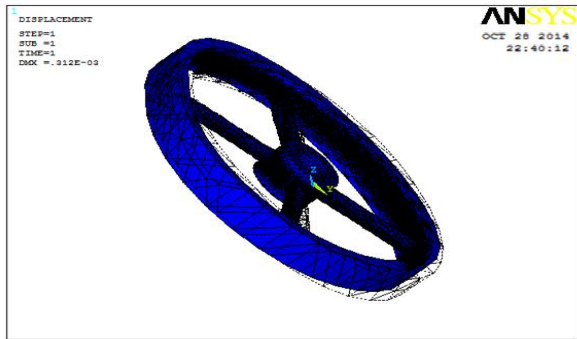

Fig 23 Displacement of Spoke type Flywheel- S Glass Epoxy

Fig 27 shows numerical investigation of Spoke type Flywheel- S Glass Epoxy , which represents the maximum stress developed in the flywheel. The von-mises stress of flywheel is 0.145×10^9 Pa is observed in the following figure.

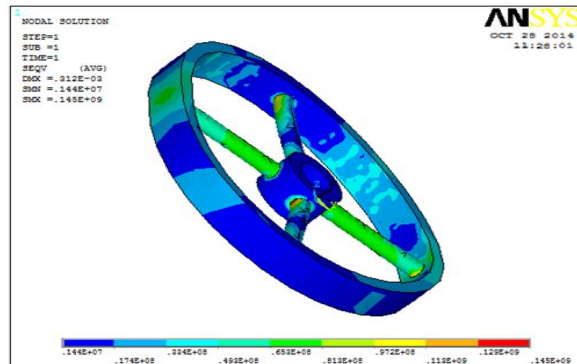

Fig 24 Nodal Solution of Spoke type Flywheel-S Glass Epoxy

4.RESULTS & DISCUSSION

4.1 Comparison Of Displacement

Table No 5.1 Comparison Of Displacement

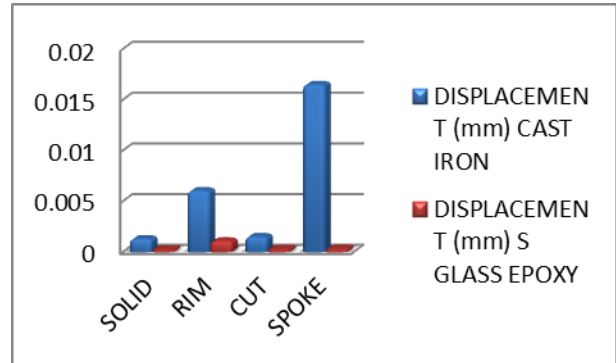

Fig 25 Displacement Comparison Chart

From the above figure, maximum deflection is developed in spoke type flywheel when using cast iron followed by rim type flywheel. This will be minimized when using glass epoxy type material.

Table 2 Displacement Result

| TYPE OF FLYWHEEL | DISPLACEMENT (mm) | |
|------------------|-------------------|---------------|
| | CAST IRON | S GLASS EPOXY |
| SOLID | .001326 | .000247 |
| RIM | .006058 | .001125 |
| CUT | .001541 | .000287 |
| SPOKE | .016528 | .000312 |

4.2 Comparison of Von Mises Stress

Table No 5.2 Comparison of Von Mises Stress

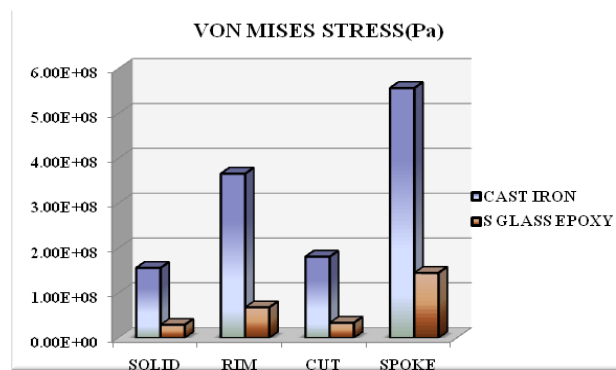

Fig 26 Von Mises Stress Comparison Chart

From the above figure, maximum stress is developed in spoke type flywheel when using cast iron followed by rim type flywheel. This will be minimized when using glass epoxy type material.

Table 3 Result of Von mises Stress

| TYPE OF FLYWHEEL | VON MISES STRESS (Pa) | |
|------------------|------------------------|------------------------|
| | CAST IRON | S GLASS EPOXY |
| SOLID | .156 x 10 ⁹ | .291 x 10 ⁸ |

| | | |
|--------------|-----------------------|------------------------|
| RIM | .366x 10 ⁹ | .682 x 10 ⁸ |
| CUT | .181x 10 ⁹ | .337 x 10 ⁸ |
| SPOKE | .557x 10 ⁹ | .145 x 10 ⁹ |

5. Conclusions

Different type of flywheels are designed and analyzed for high reliability and long life. Smart design of flywheel geometry has significant effect on its specific energy performance. Amount of kinetic energy stored by wheel –shaped structure flywheel is greater than any other flywheel. To obtain certain amount of energy stored; material induced in the spoke/arm flywheel is less than that of other flywheel, thus reduce the cost of the flywheel. From the analysis it is found that maximum stresses induced are in the rim and arm junction. Results shows that efficient flywheel design maximizes the inertia of moment for minimum material used and guarantee high reliability and long life.

References

- [1]. Bawane G —Analysis and optimization of Flywheel
ijmerr/vol.1/no.2/july2012, pp272-276.
- [2]. Bolund B, Bernhoff H, Leijon M -Flywheel energy and power storage systems / Renewable and Sustainable Energy Reviews 11 (2007) 235–258.
- [3]. Bitterly G, “Flywheel technology: past, present, and 21st century projections,” *IEEE Aerospace and Electronic Systems Magazine*, vol. 13, no. 8, pp. 13–16, 1998.
- [4]. Choudhary M —Design and Optimization of Flywheel - A Past Review IJMERR/Vol.1,Issue.XII/June 2012pp.1-4
- [5]. Dhengle M —Investigation of stresses in arm type rotating flywheelIJEST/vol.4/pp641-650.
- [6]. Dilip:P.N.,Kamal,R(2010) -An evolutionary approach for the shape optimization of flywheelI.E.(1) journal-MC,Vol.90,pp8-12
- [7]. Forrester, A. I.&Keane, A. J. (2009). Recent advances in surrogate-based optimization, *Progress in Aerospace Sciences* 45(1-3): 50–79.
- [8]. Kaftanogly B -Flywheels And Super flywheels Energy storage system/vol. I/213-219.(2010)
- [9]. Mofid M—An Optimal Two-Dimensional Geometry of Flywheel for Kinetic Energy Storage Int. J. of Thermal & Environmental Engineering Volume 3, No. 2 (2011) 67-72
- [10]. Sudipta S —Computer aided design & analysis on flywheel for greater efficiency IJAERS/Vol. I/ Issue II/299-301