

Implementation Of Smart Water Sprinkler Using Fuzzy Soft Computing Techniques

Ajay D¹, Jeyakumar R², Deeksha Hirwani², Rakshita S A², Pranjal Lengure²

¹*Department of Mathematics, Sacred Heart College, Tirupattur.*

²*School of Electronics Engineering (SENSE), VIT University, Vellore, India.*

¹*Email: dajaypravin@gmail.com*

Abstract

This paper provides an efficient sprinkler outlet size whose input parameters are optimized using genetic algorithm. The Fuzzy inference system function has been formulated from the researchers in Agricultural Research Institute Viranjipuram India. Mamdani fuzzy inference system grades the size of given set of control parameters and produce an optimised output. The whole system is evaluated in Matlab. The planned calculation exhibited better union productivity and asset usage contrasted with traditional blunder capacity.

Keywords: Fuzzy, Mamdani fuzzy inference system, Softcomputing, Neuro fuzzy systems, IF-THEN fuzzy inference systems, Genetic algorithm.

I. INTRODUCTION

In this paper we have proposed a smart water sprinkler using fuzzy logic. When it comes to watering, there are no hard or fast rules. It's a judgment call that depends on the type of plant, the humidity, the weather, the time of year and many other variables. So keeping all the parameters & then efficiently watering the plants is important. These methods of watering are seldom practiced by most gardeners. They are either under or over water when irrigating. One of the greatest and the most mainstream issues as to cultivating is under watering plants. Too little water for a plant implies it is not getting the supplements it needs from the water or the dirt. On the hand over watering leads lack of oxygen, bringing about harm to the root framework. Plant roots need oxygen to live. At the point when dirt stays spongy little oxygen is available in the dirt. At the point when this condition exists roots bite the dust and didn't really ingest water. So it is very essential to water the plants in the

garden efficiently This smart sprinkler waters the plants as per the amount of water required by different plants on different circumstances. The amount of water to be sprayed is being decided based on our defined parameters. The parameters taken into consideration are temperature, humidity & height of the plant. This project is developed in order to help the gardeners to control the amount of water for watering their plants. This system is suitable for users who use the sprinkler to watering their plants. This sprinkler decides the amount of water to spray on different plants in the garden considering the environmental conditions & nature of the plant. So, it is more optimum to use this sprinkler for better growth of the tree.

The paper presents a smart sprinkler based on the fuzzy-logic methodology & Genetic algorithm. Fuzzy rationale is a type of numerous esteemed rationale in which reality estimations of variables may be any genuine number somewhere around 0 and 1. Fuzzy rationale has been stretched out to handle the idea of halfway truth, where reality worth may range between totally genuine and totally false. While the genetic algorithm genetic algorithm based on Mamdani fuzzy inference system (FIS) that decides the output depending on the variations in our input parameter. A novel FIS grading system has been developed for this purpose based on expert guidance from Agricultural Research Institute Viranjipuram India. The designed FIS is used as fitness function to execute genetic algorithm which optimizes the fuzzy controller parameters & thus giving the best result. The proposed technique has been implemented using MATLAB. The developed Fuzzy Logic Controller (FLC) prototype is based on a Mamdani controller and it is built on MATLAB software

Genetic algorithm optimization technique used to determine the global minimum and global maximum. The algorithm is used in the design of the sprinkler pipe size for the optimum water outlet from the pipe. The input parameters are passed through the fitness function to get the optimized pipe size. The values for the input parameters are got from the Agricultural Research Institute Viranjipuram.

The paper is structured as follows: Section II gives a literature survey of sprinkler systems & fuzzy logic. Section III explains the experimental setup. Section IV gives the description of the algorithm. Section V describes about the results and Section VI concludes the paper with the future scope.

II. LITERATURE SURVEY

Quanxing Zhang and Chwan-Hwa John Wu technique is one of the widely used technique in irrigation control system. It explained about how fuzzy system can be applied in the irrigation system. Our system aims to make water conservation in sprinklers used in garden. [1]

Garden plants like rose, tomatoes require moderate water requirement depending on the soil moisture availability and the type of the soil. Table 1 describes the water requirement of different plants compared to standard grass. This table is used for calculation of pipe diameter and the amount of water from the pipe.

Enhancements in watering system innovation whether keen controllers, downpour sensors, weight managing rotors and splashes, high-effectiveness spouts, drip irrigation or a blend a little can go far. More than simply the updates in the framework, effectiveness relies on upon all segments. It is critical to modify your controller regularly, abstain from watering when down-pouring or blustery, not utilizing high weight and not over watering. A blend of new items and keeping up your watering system framework will streamline execution and screen all plantings and climate conditions.

Table 1: Water Requirement of different plants

-30%	-10%	Same as grass	+10%	+20%
Citrus Olives	Squash	Crucifers Groundnuts Melons Onions Peppers Grass	Barley Beans Maize Cotton Lentils Millet Safflower Sorghum Soybeans Sunflower Wheat	Nuts Fruits

Irrigation controller using penman-Monteith equation was proposed to meet the crop’s evapotranspiration. This method provides an automatic irrigation method taking into consideration of month after sowing crops and also evapotranspiration. This method saves lot of water than the conventional method [2]. But this is suitable for the large area cultivation not in gardens or lawns where we do not have a suitable pipe connection for watering the plants. To provide an optimized method for watering of plants in garden and lawns using sprinkler we have provided an optimized technique as described below.

III. EXPERIMENTAL SETUP

To design the prototype of the smart sprinkler system we have used the existing MATLAB Simulink tool. By using MATLAB/Simulink, Fuzzy Logic Toolbox packages the fuzzy controller was designed. Fuzzy controller takes three input parameters as its inputs analysis the inputs & den decides the most optimum output.

Fig.[1] depicts the block diagram of the smart sprinkler system. The input parameters considered in this project are temperature, Humidity & Height of the plant. All the input parameters were taken from Agricultural Research Institute Viranjipuram. The rule set can be changed as the climatic conditions vary from place to place. Our rule set is based on the information given from the research institute. Temperature is taken as input parameter as adjusting the water scheduling based on climatic conditions is important for the plant. For example, during very sunny days plants need comparatively more water as compared to less sunny days.

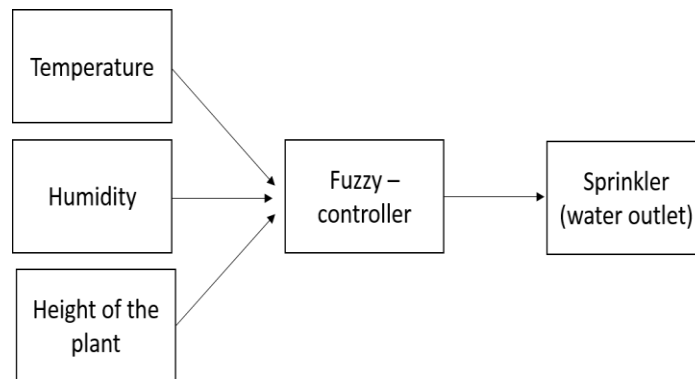

Fig 1.Block Diagram of the smart sprinkler system

During Rainy if over watering is done then even that effects the plant. So in order to supply water to the plants we have taken three membership functions under temperature they are ‘hot’, ‘moderate’ and cold. The temperature range considered is 18°C to 45°C. Hot ranges from 28°C to 45°C, moderate ranges from 22°C to 28°C and cold ranges from 18°C to 22°C. Humidity also plays an important role With respect to the need for water, a distinction can be made among three climatic situations:

Humid climates: If humidity will be 67% to 86% then water needs of plants will be less. Excess water may cause problems for plant growth and thus very less amount of water is required.

Sub-humid and semi-arid climates: If humidity between 63% to 67%. Then need of water by plants is little high comparatively to humid climates because climatic condition are little dry.

Semi-arid, arid and desert climates: If humidity ranges between 40% and 63% then it is very dry so water needs of plants are very high.

Height of the tree is our one more input parameter. It is noted that Deep soakings encourage roots to grow downwards and utilize moisture deep in the ground. The plants are then more drought resistant. - Ensure that water reaches the expected root depth - 20cm for lawn, vegetables and herbs; 60-90cm for trees and shrubs. Allow the top 8-10 cm of soil to dry out before watering again. It is generally known that taller the tree deeper are the roots so we have taken height of the tree as one more parameter so that taller trees will be provided more water compared to shorter herbs.

IV. ALGORITHM

a) Fuzzy Logic Process:

Now the Fuzzy logic tool box in MATLAB play a major role in controlling all the varying inputs. The fuzzy controller is provided with three input parameters and one output parameter. There are total 54 rules considering the changes of every input. The rule base for FIS editor was explored and verified by practical test cases.

b) Fuzzy Variables Classification and Implication:

Fuzzy Inference System has two classifications, one is antecedents and the other is consequent. Further Fuzzy antecedents include temperature, humidity and height of the plant and consequent has size of the pipe which will decide volume of water. Fig [2] shows the classification of antecedents and consequents. The variables are classified based on their values such as temperature is classified as hot, moderate and cold. Here we have considered triangular membership function. The amount of water can be computed by the fuzzy rule base which comprises of 54 sample fuzzy grading rules that have been obtained using experimental observation. The designed fuzzy rule plays an important role in determining efficiency of the system and also exceptional cases have been considered to develop the rules.

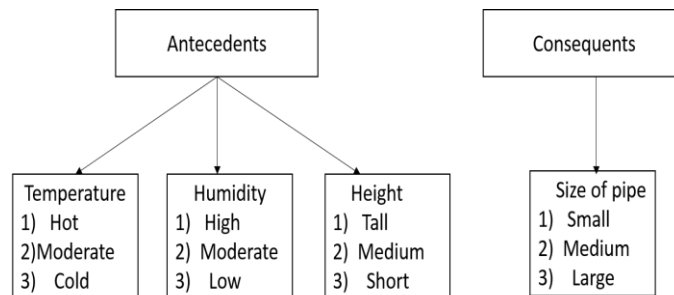

Fig.2 Classification of Antecedents and Consequents

Table[2] shows a sample of fuzzy rule set developed for our project which mimics human reasoning. In this step fuzzy rules are constructed for different inputs to perform different actions. Fuzzy inputs associate with fuzzy output by fuzzy rules. The input for this FIS rule set is decided based on the information collected from Agricultural Research Institute Viranjipuram while the optimized value of output that is the size of the pipe is based on Genetic Algorithm. The surface obtained by fuzzy rules is shown in Fig [3].

D) Control using Genetic Algorithm:

From the fuzzy rules we get the size of the pipe based on the input parameters. But the optimized value of the pipe size for a particular area depending on the type of the plant is determined by the genetic algorithm. This helps to conserve a lot of water and to grow the plants in a healthy condition in a more optimized way. The local minima value shows that the

outlet diameter obtained is a more optimized value. The optimized graph is shown in Fig [4].

Table 2 Fuzzy Rules

IF			THEN
Temperature	Height	Humidity	Size of pipe
Hot	Short	High	Medium
Hot	Short	Low	Small
Hot	Short	Moderate	Small
Moderate	Medium	High	Medium
Moderate	Medium	Low	Medium
Moderate	Tall	High	Large
Cold	Tall	High	Small
Cold	Short	Low	Small
Cold	Medium	High	Medium

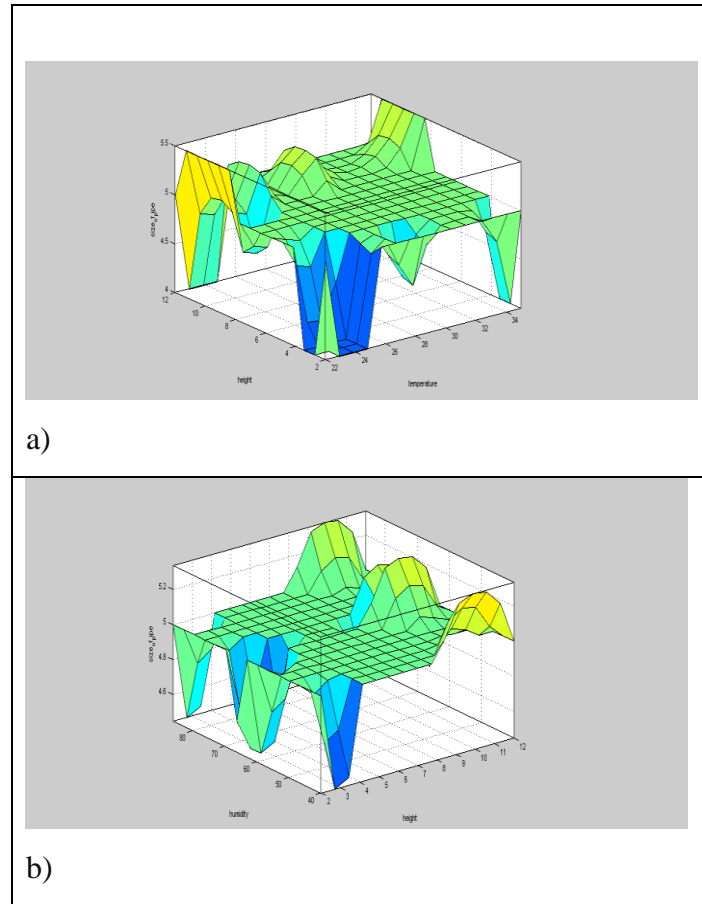

Fig.3 The Surface Obtained by Fuzzy Rules

V. RESULTS AND DISCUSSION:

The optimised size of the pipe was obtained for the different values of the input parameters and this has been experimentally verified. The values of the size of the output shows that the pipe diameter is an optimised value and the water output can be used based on the climatic conditions and the height of the plant. The diameter can be adjusted automatically based on the fuzzy controlled sensor. This saves a lot of water of water in the near future in agriculture.

The fitness function equation is used to perform the optimised value of the genetic algorithm is mentioned in equation 1.

$$Fitness_func = abs(x - 33.46) + abs(y - 55) + abs(z - 3) \quad (1)$$

The graph between the fitness function and the mean value is shown in fig [4]. The graph shows that the optimization is good and the process does not anywhere in

between while running. The same technique can also be used in places where water conservation is needed. For a country like India where both water and agriculture becomes a primary concern to people this technique will be helpfull.

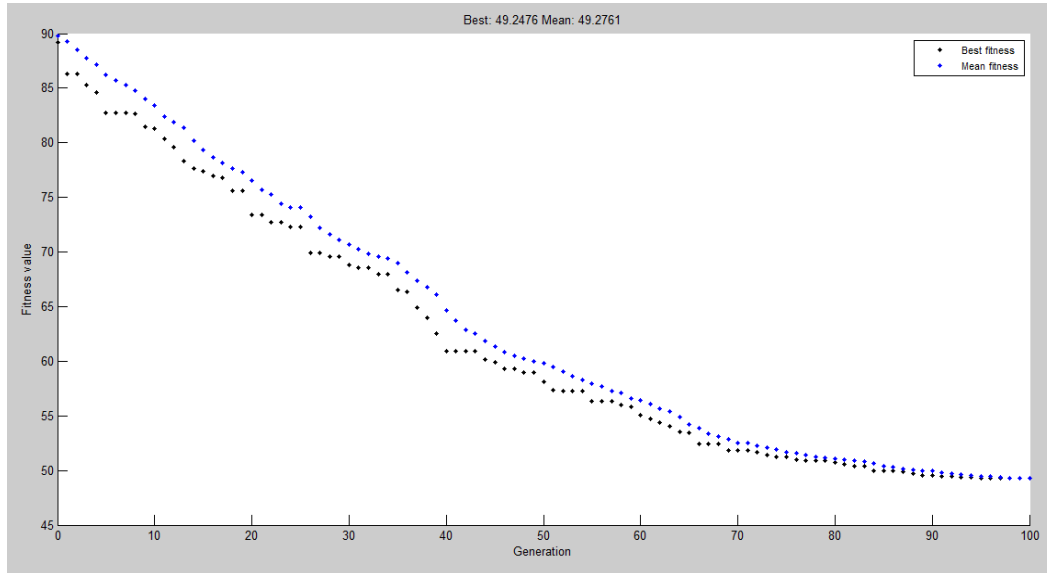

Fig.4 Optimized Graph

VI. CONCLUSION

The optimization results show that genetic algorithm converges faster and provides an optimum outlet size for conserving water. The same can be applied with sensors to determine the soil moisture level and still better optimized result can be obtained.

REFERENCES

- [1] Quanxing Zhang ; Dept. of Electr. Eng., Auburn Univ., AL, USA ; Wu, C.-H.J. ; Tilt, K., "Application of Fuzzy Logic in an Irrigation Control System" pp. 593-597, Dec 1996.
- [2] V. S. Rahangadale, D. S. Choudhary, "On Fuzzy Logic based Model for Irrigation Controller using Penman-Monteith Equation ",2nd National Conference on Information and Communication Technology (NCICT) 2011
- [3] Ioslovich, I. P. Gutman and I. Seginer, 2006. A non linear optimal greenhouse control problem with heating and ventilation. Optimal Control Applications and Methods, 17: 157-169.
- [4] Eldredge, Eric P., Clinton C. Shock and Timothy D. Stieder. 1993. Calibration

- of Granular Matrix Sensors for Irrigation management. *Agronomy Journal* Vol 85:1228-1232(1993).
- [5] Ioslovich, I. P. Gutman and I. Seginer, 2006. A non linear optimal greenhouse control problem with heating and ventilation. *Optimal Control Applications and Methods*, 17: 157-169.
 - [6] Lin, M.C., Wang, C.C., Chen, M.S., & Chang C. A. (2008), Using AHP and TOPSIS approaches in customer-driven product design process. *Computers in Industry*, 59(1), 17-31.
 - [7] Zadeh, L.A. (1975), The concept of a Linguistic variable and its Application to Approximate Reasoning (Part II), *Information Science*, 8, 301-357.
 - [8] Zadeh, L.A. (1965). Fuzzy Sets. *Information and Control*, 8(2), 338-353.

