

Systematic study of octupole correlation in the A~130 mass region

Gurmeet Kumar, Rajesh Kumar* and Surender Kumar

PG Department of Physics, JCDAV College, Dasuya (Punjab)-144205, India

E-mail: rkthakur1@yahoo.co.in

Abstract— The nuclei around A~130 mass region below $N = 82$ shell closure are γ -soft deformed nuclei at low and intermediate spins, and exhibit various intriguing phenomena. The present work reports the theoretical and experimental evidences of octupole correlation in this mass region for some of the nuclei. Various possible and associated phenomena have been discussed in order to make it more reasonable. Octupole correlation represents the structural behavior of the atomic nuclei at high spin which can arise when nucleons near the Fermi surface occupy states of opposite parity with orbital and total angular momentum differing by $3\hbar$. A nucleus with octupole deformation has reflection asymmetric shape. It has been seen that the maximum octupole coupling occurs just above the close shells ($Z, N = 34, 56, 88$ and 134). Octupole correlation is an essential property in order to describe the energy of low lying collective negative parity states and $E1/E3$ transition strengths. Several theoretical and experimental calculations have suggested the presence of octupole correlation in Ba, Cs and Xe isotopes.

Index Terms— γ - γ coincidence, spin-parity, fusion evaporation reaction, Electromagnetic transitions, γ -transitions and level energy.

For nuclear structure theory, octupole deformed nuclei have exceptional importance and can be characterized by the breaking of reflection symmetry. Octupole correlation in atomic nuclei is due to the interaction between the orbitals of opposite parity whose angular momentum differ by 3 units ($\Delta j = \Delta l = 3$) near Fermi level. This situation is found between an intruder orbital and normal parity sub-shell *i.e.* for particle number 34 ($g_{9/2} \rightarrow p_{3/2}$), 56 ($h_{11/2} \rightarrow d_{5/2}$), 88 ($i_{13/2} \rightarrow f_{7/2}$) and 134 ($j_{15/2} \rightarrow g_{9/2}$). The nuclei that have their Fermi surface in close proximity to these pair of orbitals will be particularly susceptible to octupole correlation effect. Such orbitals play an important role in generating spin of heavy rotating nuclei and give rise to the characteristic backbending phenomenon, observed commonly in nuclei with quadrupole deformation.

Date of submission: 03-11-2016.

Authors acknowledge the joint effort of IUAC, New Delhi, TIFR, Mumbai, and IUC-DAEF and SINP, Kolkata, in establishing the INGA clover array and also to IUAC, New Delhi, for providing funds for this work under grant UFR 54309.

Quadrupole–octupole coupling is small for quadrupole deformed nuclei, but a more systematic calculation covering spherical or near spherical is in order. One of the interesting points is the observation that these octupole correlations can develop or be enhanced as a consequence of dynamical effects, which cause an energy shift of effective orbitals, like the deformation induced by rapid rotation of excited nuclei. Octupole correlations are essential to describe the energy of low lying collective negative parity states and $E1$ and $E3$ strengths. They also have an impact on binding energy and quantities like nucleon separation energy. Octupole shape has weaker pairing correlation, which increases the moment of inertia. Also with increasing rotational frequency, the reflection asymmetric minimum shifts towards larger values of β_1 and β_2 and smaller β_3 [1]. Hamilton *et al.* [2] gives the experimental evidence which supports this fact.

I. EXPERIMENTAL FINGER-PRINTS OF OCTUPOLE CORRELATION

Experimental fingerprints of octupole correlation have been observed, such as low lying negative parity states, alternate parity bands linked by enhanced $E1$ transitions, very collective $E3$ transition and parity doublet in odd-odd nuclei. Retarded appearance of back-bending at increasing spins, are in fact long established in proximate $N=88, Z=56$ corresponding to ^{144}Ba and $Z=56, N=56$ corresponding to ^{112}Ba . An obvious manifestation of reflection asymmetry in nuclei is the occurrence of low-lying negative-parity states which are collective in nature. States having such properties were first identified in Ra and Th isotopes with $N=136$ by the Berkeley group [3] using α -spectroscopy. In this mass region the 1^- and 3^- states remain energetically higher than the 2^+ and 4^+ states, respectively, which rules out a simple interpretation in terms of octupole deformation. In ^{124}Ba [4], the low lying negative parity states have also been observed. For actinide nuclei, the minimum of the energy of negative-parity states is very localized in N , while there are insufficient data to determine the corresponding localization in Z . For the lanthanide region, this minimum value is attained outside the transitional region where octupole effects are strongest ($N \geq 90$). The systematic behavior of excited negative-parity states has been discussed by several authors [5,6]. Peker *et al.* [6] has concluded that a vibrational interpretation is appropriate and that the behavior of the negative-parity states can be explained in terms of Coriolis coupling between the $K^\pi = 0^-, 1^-, 2^-$, and 3^- bandheads. Zamfir *et al.*, [7] have established a simple parametrization for

the energies of 3^- states in all nuclei with $A \geq 30$ and conclude that deviations from normal behavior characterize nuclei, having the strongest octupole correlations (they are in the transitional lanthanide and actinide regions).

A common property of nuclei exhibiting the features of octupole correlation is the occurrence of relatively enhanced $E1$ and $E3$ transitions between the yrast positive and negative parity bands. The first observations of such band structure in heavy nuclei were in ^{218}Ra [8] and ^{222}Th [9]. In medium-mass nuclei, sequences of nuclear states with similar features were observed much earlier, the first connection with static octupole deformation in this mass region was made by Phillips *et al.* [10], who studied $^{142,144,146}\text{Ba}$ using fission spectroscopy.

A. Octupole correlation in $^{118,120,122,124,125}\text{Ba}$

Smith *et al.* have reported the first observation of excited states in ^{118}Ba which is the most neutron-deficient barium

statistics ($<10 \times 10^6$ events) only one of the side bands could be firmly connected to the yrast cascade. The part of experimental decay scheme deduced by Cederwall *et al.* is shown in fig. 1. TRS calculations have been performed for ^{120}Ba . In these calculations the ground state deformation is $(\beta_2, \gamma) = (0.27, 0^\circ)$ and the deformation of the ground band goes towards slightly negative γ -values ($\gamma \approx -5^\circ$) with increasing rotational frequency. The alignment of $h_{11/2}$ protons is predicted at $\hbar\omega = 0.36$ MeV, directly followed by the $\nu h_{11/2}$ alignment at $\hbar\omega = 0.42$ MeV.

Smith *et al.* have also studied the high spin states ^{120}Ba [13]. The high spin states have been extended up to $42\hbar$. Smith *et al.* have reported that, by comparing the experimental properties of a rotational alignment to the predictions of the cranked shell model (CSM), it is possible to deduce information about the structure of the nucleus and about

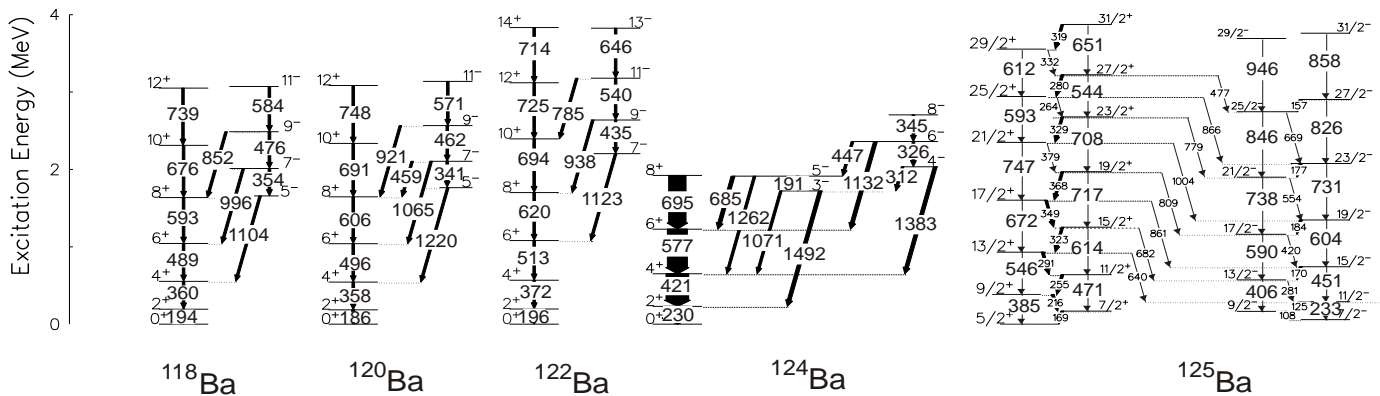

Figure 1. Partial level schemes of $^{118,120,122,124,125}\text{Ba}$ nuclei.

isotope to which excited states are assigned [11]. The ground-state band and a side band are observed up to spins $20\hbar$ and $17\hbar$, respectively. The side band decays into the ground-state via three transitions which presumably have $E1$ character. This structure is suggestive of octupole correlation. Part of band structure of ^{118}Ba showing octupole correlation shown in Fig. 3.

The strength of octupole correlation is difficult to quantify experimentally and it is often inferred from the relative excitation energies of the positive and negative parity states, or from the strength of $E1$ transitions. This suggests that in the lighter barium isotopes the positive- and negative-parity states may form an interleaving sequence with the I states lying lower in energy than the adjacent $(I+1)^+$ states at low spin. The observation of such a band would present a valuable insight into octupole collectivity in this region.

There is no any experimental evidence for octupole correlation in ^{120}Ba till now. The high spin states of very neutron deficient nucleus of ^{120}Ba had studied first by Cederwall *et al.* [12]. The yrast band of ^{120}Ba is extended up to spin $22\hbar$ and one tentatively assigned negative-parity side band is observed up to spin $15\hbar$. Nuclear properties at high spin depends on interplay between structures based on proton and neutron $h_{11/2}$ configurations in this mass region.

Excited states in ^{120}Ba were populated via the $^{92}\text{Mo}(^{32}\text{S}, 2p2n)^{120}\text{Ba}$ reaction. Due to the relatively low

aligning nucleons. Alignments in the well-deformed and neutron-deficient barium isotopes are particularly interesting because both the neutron and proton Fermi levels lie within the $h_{11/2}$ subshell. The proton Fermi level lies in the low- Ω oblate driving orbitals. As the neutron number decreases from $A \approx 130$ to 120, the neutron Fermi level successively moves to lower- Ω orbitals. Furthermore, in the very neutron-deficient barium isotopes with $A \approx 120$, the neutron Fermi level will lie in close proximity to the proton Fermi level, suggesting that a pn -interaction may begin to influence the nuclear structure. Smith *et al.* have reported in their study, two alignments are observed in the heavier even-even barium isotopes, resulting in the apparent forking of the yrast band into two aligned bands. The aligned bands are assigned to have the $\nu(h_{11/2})^2$ and $\pi(h_{11/2})^2$ configurations, on the basis of CSM calculations.

The neutron-deficient nucleus ^{122}Ba was studied in 2001 by Jiang *et al.* [14]. In previous reports, negative-parity side bands have been observed in some even-even nuclei in this region and some of these show evidence for octupole correlations. In the study by Jiang *et al.* Ref. [14], the ground-state band has been extended up to a spin $20\hbar$ with band crossing. Also, a negative-parity side band extending up to a spin state of $19\hbar$ is observed. States in this side band decay into those of the ground-state band via three transitions with

the appearance of $E1$ transitions. This structure is suggestive of octupole correlations.

The portion of level scheme of ^{122}Ba is shown in fig. 1 by Jiang *et al.* The negative-parity band is connected to the ground-state band via three linking transitions with energies of 1123, 938 and 785 keV. The DCO ratio measurements suggest that the 938 keV transition linking between bands (B1) and (B2) has a stretched dipole transition character. Some calculations have predicted that octupole correlation will occur around ^{112}Ba . The calculations predict that the degree of ground state octupole deformation will decrease rapidly as N increases above 56, but the octupole correlations at about 6 or $8\hbar$ in the heavier $N\sim 60$ barium isotopes may also be large since the rotation will enhance the octupole correlation.

Very recently Shivcharan *et al.* have made an attempt to establish the unknown spin-parity of these bands using the linear polarization measurements [15]. They have also confirmed some linking transitions between negative and positive parity bands.

Three tentative linking transitions 504 keV ($7^- \rightarrow 8^+$), 802 keV ($5^- \rightarrow 6^+$) and 992 keV have been confirmed. According to Shivcharan *et al.*, the strong $E1$ transitions 938 keV and 787 keV shows the evidence of octupole correlations.

Level scheme reported by Mason *et al.* display two major structures (i.e., couples of bands of common parity linked by $M1 + E2$ transitions) having opposite parities, interpreted as quasi-neutron bands respectively based on the $d_{5/2}$, $g_{7/2}$ and $h_{11/2}$ orbitals. This interpretation is suggestive of octupole correlations, in that the observation of enhanced $E1$ transitions linking the two structures would then signify an enhanced interaction between the $d_{5/2}$ and $h_{11/2}$ orbitals, i.e., an octupole interaction.

To check the enhancement of $E1$ strengths octupole correlations are expected to produce finally measured branching ratios, which in turn yielding $B(E1)/B(E2)$ values [16]. Results are reported, in which $B(E1)$ estimates that the nucleus ^{125}Ba has a prolate shape with a somewhat 'cautious' deformation of $\beta=0.2$ are also shown. A definite enhancement of $E1$ strengths, is observed in ^{125}Ba , pointing to a sizable contribution of octupole correlations to the structure of this nuclide with $\nu d_{5/2}(+g_{7/2})$, $\nu h_{11/2}$ bands.

Experimental results by Mason *et al.* in case of ^{124}Ba are just indicative of octupole correlations [16]. $B(E1)/B(E2)$ ratios were also determined for three levels in this nucleus, namely the $J^\pi = 11, 9^-, 7^-$ ones; [16], along with $B(E1)$ estimates corresponding to the nucleus ^{124}Ba having an electric quadrupole moment $Q_0=385 \text{ fm}^2$. The observed enhancement of $E1$ strengths would not be expected if the negative-parity odd-spin band, yet interpreted as a $\pi(d_{5/2} + g_{7/2}) \otimes \pi h_{11/2}$ structure, had a purely rotational origin. Their experimental findings, indicate that octupole correlations must be included in a proper description of negative-parity states in ^{124}Ba at least $J\sim 11\hbar$.

The identification of several new $E1$ transitions and the measurement of $B(E1)/B(E2)$ ratio indicate that the $\nu d_{5/2}$, $\nu g_{7/2}$ and $\nu h_{11/2}$ interpretation of two major structures in ^{125}Ba must be integrated with the inclusion of octupole correlations.

B. Octupole correlation in $^{143,144,146}\text{Ba}$

J.H. Hamilton *et al.* have shown the evidence of octupole correlation in $^{143,144,146}\text{Ba}$ [2]. Of particular importance will be the role of nuclear rotation in enhancing stable octupole deformation as the nuclear rotation increases in some cases and quenching ($\beta_3=0$) of stable octupole deformation as the nuclear rotation increases in other cases as theoretically predicted.

In their first report [17], new high spin states in $^{142-146}\text{Ba}$ and the first evidence for octupole deformation in an odd- A nucleus in this region ($N = 87$), ^{143}Ba were found. From their previous work, J.H. Hamilton *et al.* extracted new insights into the importance of stable octupole deformation in these nuclei [2]. The part of new level schemes for $^{143,144,146}\text{Ba}$ are shown in Fig. 3. Similar level schemes were simultaneously extracted from Eurogam II data in SF of ^{248}Cm by Urban *et al.* and Jones *et al.* [18,19].

When reflection asymmetric stable octupole deformation occurs in odd- A nuclei, the level structures are similar to rotational bands in reflection-asymmetric molecules including two pairs of parity doublets with the same spins but opposite parities in each doublet, the simplex $s=i$ and $-i$ doublets [20]. Each doublet pair is intertwined by enhanced $E1$ transitions. The first two, $E1$ intertwined opposite parity bands were observed in an odd- A nucleus in this region in ^{143}Ba .

Jones *et al.* [19] found the $s=i$ doublet pair with the same spins but opposite parities. Their newer data likewise show both parity doublets. $B(E1)\sim 1\times 10^{-3} \text{ W.u}$ for the $s=-i$ doublet and $\sim 0.4\times 10^{-3} \text{ W.u}$ for new $s=i$ doublet, values similar to those in ^{144}Ba . In addition recently they find three new $E1$ crossing transitions and five new presumably $M1$ transitions between the $s=i$ and $-i$ bands which were not reported by Urban *et al.* [18]. These $E1$ and $M1$ transitions between the two doublets measure the degree of mixing of the $s=i$ and $-i$ doublets. The levels of $^{145,147}\text{Ba}$ are strikingly different from those of ^{143}Ba [2] with their ground bands having quite different structures with no evidence for stable octupole deformation. This difference between ^{143}Ba and ^{145}Ba is surprising since the ^{145}Ba core, ^{144}Ba has the strongest electric dipole moment D_0 's, most enhanced $E1$'s and largest $\beta_3=0.10$ in this region. In fact, the average D_0 values are significantly larger for the higher spin states than for the lower spin states, to indicate rotation enhances the stable octupole deformation in ^{144}Ba in agreement with theory.

C. Octupole correlation in ^{122}Cs and ^{124}Cs

In case of the Cs isotopes as the neutron number decreases towards mid-shell $N=66$, the neutron Fermi level also lowers into the low $\Omega h_{11/2}$ orbitals and the possibility of the residual interaction between the valence protons and the neutrons increases. The observation of nearly degenerate twin $\pi h_{11/2} \otimes \nu h_{11/2}$ bands has been cited [21,22] as evidence for the chiral symmetry breaking in these nuclei.

Rajesh Kumar *et al.* have made an attempt to establish the unknown spin-parity of observed bands using the linear polarization measurements [23]. They have also confirmed some linking transitions between negative and positive parity bands as the evidence of octupole correlation in these nuclei. High-spin states in the ^{122}Cs nucleus were populated using the

$^{107}\text{Ag}(^{19}\text{F}, p3n)^{122}\text{Cs}$ fusion evaporation reaction at a beam energy of 93 MeV. Multipolarity of the de-exciting γ -rays were deduced from the observed γ - γ angular correlation measurements. DCO ratio measurement helps in unambiguous assignment of both spins and parities of nuclear states. The clover detector was used as a polarimeter to measure the polarization of the γ -rays. Figure 2 shows the part of level scheme of ^{122}Cs . Multipolarity assignments were corroborated

the $E2$ character. Thus, the 270.0keV level is assigned as 3^+ . The missing ~ 31 keV transition should have an $E1$ character. This nucleus was studied later by Yang Dong *et al.* and the part of level scheme from their work is shown in Fig. 2. The key of the problem is whether there are linking transitions between bands 1 and 2. Yang Dong *et al.* have obtained plenty of information in their work proves that they do exist: the first evidence is the coincidence relation observed between the linking and intraband transitions. From the level scheme

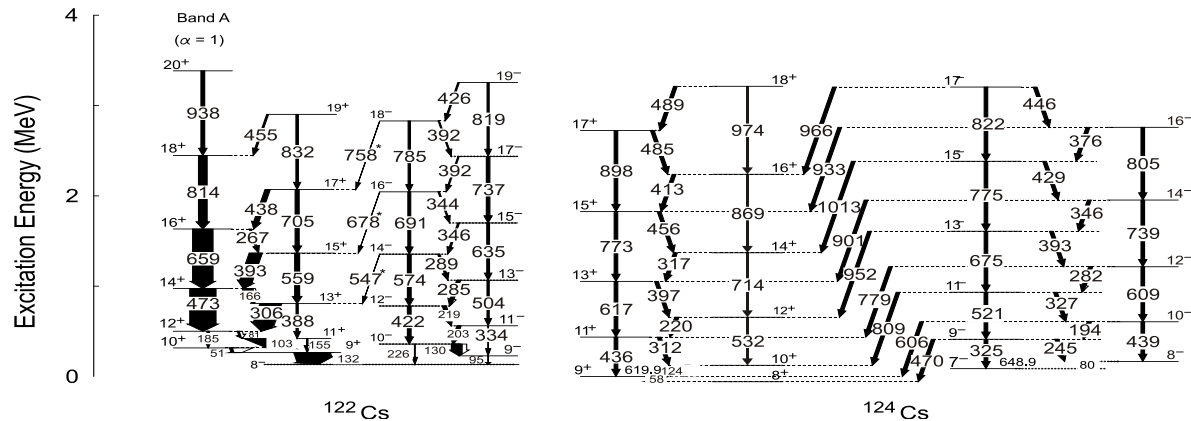

Figure 2. Partial level schemes of ^{122}Cs and ^{124}Cs .

by the γ -ray linear polarization measurements. The use of Clover detectors facilitated polarization measurements.

The new linking transitions of 547($14^- \rightarrow 13^+$), 678($16^- \rightarrow 15^+$) and 759($18^- \rightarrow 17^+$) keV of $E1$ or $E3$ character between the negative-parity band B and the positive-parity band A which indicate the octupole collectivity in this nucleus. It would be of interest to explore the multipolarity of these transitions by lifetime measurements. Because of strong mixing of $\nu d_{5/2}$ orbital ($l = 2$) of negative parity band B and the $\nu h_{11/2}$ configuration ($l = 5$) of band A, there is a possibility of $\Delta l = 3$ octupole transition between these two bands. This, however, needs to be further confirmed with the measurement of the transition probability. This is also very fortunate to obtain signature of octupole correlation when neutron number is greater than 56 i.e. $N > 56$. So need more appropriate theoretical description of octupole correlation.

For ^{124}Cs , due to its abundant information in both low-lying and high spin states, much attention has been paid to it in systematic study and theoretical calculation. The ^{124}Cs nucleus was studied first time by Jing-Bin *et al.* by performing a $^{116}\text{Sn}(^{11}\text{B}, 3n)^{124}\text{Cs}$ fusion evaporation reaction [24].

From Analysis, the five rotational sequences of ^{124}Cs observed and four of them are involved in figure 4. Linking γ rays, i.e., 576.2, 750.6, 749.2, 893.5, 871.0 keV between side bands (3,4) and yrast bands (1,2) are observed. The connection between the rotational bands and low-lying states fix the level energies of the yrast bands which suggests that there still exist a ~ 12 keV transition between the 489.8keV, 7^+ level and the 478.1 keV, 5^+ level (Fig.2).

The DCO ratio of the 270.0keV γ -ray depopulating the 270.0keV level is deduced to be ~ 1.05 , which limits this ray to be a quadrupole transition. The large intensity of the 270.0keV γ -ray in the prompt coincidence measurement fixes it to have

in figure 2, 266.7($8^- \rightarrow 7^+$), 412.2($9^- \rightarrow 8^+$), 576.2($10^- \rightarrow 9^+$), 750.6($11^- \rightarrow 10^+$), 749.5($12^- \rightarrow 11^+$), 893.5($13^- \rightarrow 12^+$), and 871.0($14^- \rightarrow 13^+$) keV transitions connecting bands 1 and 2 can be seen clearly. The second evidence is three linking transitions of 529.4($9^- \rightarrow 8^+$), 867.9($11^- \rightarrow 10^+$) and 986.7($13^- \rightarrow 12^+$) keV found in [25] connecting bands 1 and 3. Similar linking transitions have been reported in the isotope ^{122}Cs [23] providing the fourth evidence which is from the systematic study. Considering the facts mentioned above, the linking transitions have been proved to exist. Then level energies of band 1 are fixed by its connections with bands 2 and 3.

Moreover, a new cascade sequence denoted as band 4 is established in Yang Dong *et al.*'s work, its decouple character and connection with band 3 indicate that it most likely corresponds to the unfavored signature partner of the $\pi h_{11/2} \otimes \nu d_{3/2}$ band in figure 2. The $E1$ linking transitions between the yrast and $\pi h_{11/2} \otimes \nu(d_{5/2}, g_{7/2})$ bands has been proposed. Such enhanced $E1$ transitions linking alternate-parity bands are the experimental fingerprint of octupole correlations.

Very recently work, K. Selvakumar *et al.*, have found evidence for octupole correlation in ^{124}Cs [26]. Lifetime have been measured using Doppler Shift Attenuation Method (DSAM) for the negative parity, $\pi h_{11/2} \otimes \nu(g_{7/2}d_{5/2})$ and the positive parity, $\pi h_{11/2} \otimes \nu h_{11/2}$ bands of ^{124}Cs . The $B(E1)$ transition rates have been deduced for the linking transitions between the bands with the above configurations and a possibility of octupole correlation is discussed.

The linking transitions proposed in the earlier work [27] was confirmed by Selvakumar *et al.* [26]. The $B(E1)$ rates for the linking transitions connecting negative parity (band 3) and positive parity (band 1) bands have been deduced. The

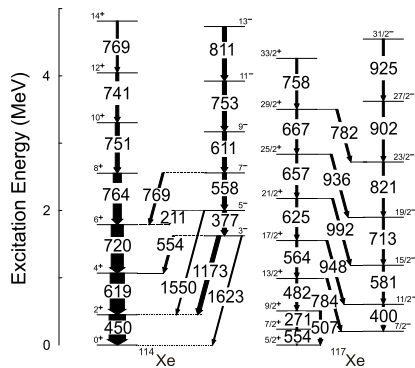

Figure 4. Partial level schemes of ^{114}Xe and ^{117}Xe .

The high efficiency of the EUROBALL array for high energy γ rays has allowed the identification of two $E3$, γ -transitions of 1549.1(5) and 1623(1)keV, respectively, connecting the 5^- level at 2000 keV to the 2^+ at 450.1 keV and the 3^- at 1623 keV to the ground state.

In the presence of low lying octupole correlation, a large $E1$ moment may arise in the intrinsic frame due to shift between center of mass and center of charge. Such a dipole moment manifests itself by enhanced electric dipole transitions between members of opposite parity rotational bands, hence these $E1$ transition are considered as the most prominent experimental feature pointing to existence of octupole correlation, especially for those nuclei having no octupole minimum deep enough on its potential energy surface. Such $E1$ transitions have been seen in ^{114}Xe [28] and ^{110}Te [33]. The previously known $\nu h_{11/2}$ bands (labeled 1,2) and $\nu g_{7/2}$ $\alpha = -1/2$ band (labeled 3) have been confirmed, extended by Torrmanen *et al.* with a completely new band labeled 4 in Fig. 4.

The linking transitions from band 4 to band 1 are $E1$ transitions, in agreement with their DCO ratios (~ 0.6) and the angular distribution of the 968keV transition ($A_2/A_0 = -0.36$, $A_4/A_0 = 0.00$, $\delta = 0.06$). On the other hand, band 4 shows the following unusual features: No transition connecting bands 3 and 4 are observed, while five intense $E1$ transitions from band 4 to the negative-parity yrast band 1 are seen.

$B(E1)$ values have been calculated for the $E1$ linking transitions between band 4 and 1. The $B(E1)$ values of the transition between bands 4 and 1 are similar to that of the enhanced $E1$ transition observed in ^{114}Xe . These enhanced $E1$ transitions show octupole correlations in ^{117}Xe . But in theoretical studies [1,34], only the nuclei with N and Z very close to 56 in this region are expected to possess octupole collectivity. The neutron number of ^{117}Xe differs from 56 by 7 and no octupole softness was predicted for this nucleus. The experiment observation of octupole correlations in ^{117}Xe is not in agreement with the theoretical calculations and calls for further theoretical studies of octupole effects in this region.

II. SUMMARY AND CONCLUSION

The theoretical and experimental evidences of octupole correlation of atomic nuclei like Ba, Cs and Xe have been reviewed. The linking transitions between positive and negative parity bands have been seen which is the evidence for

octupole correlation in these nuclei. In the case of barium, a negative parity band has been observed in all of the even-even barium isotopes with $A < 132$. The observation of this low lying negative-parity band, decaying by relatively strong $E1$ transitions is proposed as possible evidence for octupole correlations. The calculations predict the deformation will be a maximum for ^{118}Ba which establish a lower limit on the trend of increasing deformation in the neutron-deficient barium isotope. In the case of neutron deficient nucleus ^{120}Ba even this nucleus have $Z=56$ there is no any discussion about octupole correlation for this nucleus. So it needs further investigation. The earlier investigation for the level structure of ^{122}Cs have not reported any signature for octupole but in the later work Rajesh *et al.*, have made an attempt to establish the unknown spin-parity of these bands using the linear polarization measurement. So it would need more appropriate theoretical description for octupole correlation. One conclude that up to $N=86$ and the $Z=50$ gap exist lower limit, in the proton number of the region of octupole deformation but in the neutron rich lanthanides is at $Z=55$. In the case of ^{124}Cs , octupole correlation is not predicted for this nucleus, but very recently the octupole correlation was confirmed in ^{124}Cs . It still remain an open question where is the border line for octupole deformation. Now in the case of Xe, according to theoretical studies only the nuclei with N and Z very close to 56 in this region are expected to possess octupole collectivity, the neutron number in ^{117}Xe differs from 56 by 7 and no octupole softness was predicted. But experimental observation of octupole correlation in ^{117}Xe is not in agreement with the theoretical calculations and calls for further theoretical studies of octupole effects in this region.

This work highlights the absence of any satisfactory conclusion for octupole correlation and reiterates the need for calculations to be performed for the satisfactory results for octupole correlation in this mass region.

REFERENCES

- [1] P. H. Heen *et al.*, Phys. Rev. C vol.50, 2 (1994).
- [2] J. H. Hamilton *et al.*, Acta Physica Slovaca Vol.49 Number-1, 31-42 (1999).
- [3] Asaro, F. F. Stephens, Jr., and I. Perlman, 1953, Phys. Rev. 92, 1495.; Stephens, F.S., Jr., F. Asaro, and I. Perlman, 1955, Phys. Rev 100, 1543.
- [4] P. Mason *et al.*, Phys. Rev. C 72, 064315 (2005).
- [5] Neergard, K., and P. Vogel, (1970), Nucl. Phys. A 145, 33.
- [6] Peker, L.K., J. H. Hamilton, and J.O. Rasmussen, (1981), Phys. Rev. C 24, 1336.
- [7] Zamfir, N.V., R. F. Casten and P. von Brentano, (1989), Phys. Lett. B 226, 11.
- [8] Fernandez-Niello, J. H. Puchta, F. Riess, and W. Trautmann, (1982), Nucl. Phys. A 391, 221.
- [9] Ward, D., G. D. Dracoulis, J. R. Leigh, R. J. Charity, D. J. Hinde, and J. O. Newton, (1983), Nucl. Phys. A 406, 591.
- [10] Phillips, W. R., I. Ahmad, H. Emling, R. Holzmann, R. V.F. Janssens, T. L. Khoo, and M. W. Drigert, (1986), Phys. Rev. Lett. 57, 3257.
- [11] J. F. Smith *et al.*, Phys. Rev. C Vol. 57, NUMBER 3 (1998).
- [12] B. Cederwall, A. Johnson *et al.*, Z. Phys. A338 (1991) 461.
- [13] J.F. Smith *et al.*, Phys. Lett. B 483 (2000).
- [14] Zhu Sheng-Jiang *et al.*, Chin. Phys. Lett. 18, 1027(2001).
- [15] Shivcharan Verma, Navneet Kaur *et al.*, Proceedings of the DAE Symp. on Nucl. Phys. 59 (2014).
- [16] P. MASON *et al.*, Phys. Rev. C 72, 064315 (2005).
- [17] S.J Zhu *et al.*, Phys. Lett. B 357 (1995).
- [18] W. Urban *et al.*, Nucl. Phys. A 613 (1997).
- [19] M.A. Jones *et al.*, Nucl. Phys. A 605 (1996).
- [20] W. Nazarewicz, P. Olanders: Nucl. Phys. A 441 (1985).

- [21] T.koike, K.starosta *et al.*, Phys. Rev. C 67, 044319 (2013).
- [22] K. Starosta *et al.* Phys. Rev. Lett.86, (2001).
- [23] R. Kumar *et al.*, phys. Rev. C 72, 044319 (2005).
- [24] Lu J B *et al.*, Phys. Rev. C 62057304, (2000).
- [25] YANG Dong *et al.*, CHIN. PHYS. LETT. Vol. 26, No. 8 (2009).
- [26] K. Selvakumar *et al.*, Phys. Rev. C 92, 064307 (2015)
- [27] Gizon A *et al.*, Nucl. Phys. A 69463 (2001).
- [28] S. L. Rugari *et al.*, Phys. Rev. C 48(1993).
- [29] S. Ćwiok and W. Nazarewicz, Nucl. Phys. A 469, 367 (1989).
- [30] W. Urban *et al.*, Phy. Rev. C 69, 017305 (2004).
- [31] W. Urban *et al.*, Z. Phys. A 358, 145 (1997).
- [32] G. de Angelis *et al.*, Phys. Lett. 535B, 93 (2002).
- [33] E. S. Paul *et al.*, Phys. Rev. C 50 (1994).
- [34] J. Skalski, Phys. Lett. B 238 6 (1990).