

## Wheel Steering System

**Md. Danish Akhtar**

*Global Academy of Technology, Bangalore  
Vishveshvarya Technological University.*

### Abstract

Nowadays most of the vehicles use the two wheel steering mechanism as their main handling system. But the efficiency of the two wheel steering vehicle is proven to be low compared to the four wheel steering vehicles. Four wheel steering system can be employed in some vehicles to improve steering response, increase vehicle stability while moving at certain speed, or to decrease turning radius at low speed.

Four-wheel steering is a technologically, tremendous effort on the part of automotive design engineers to provide near-neutral steering. In situations like low speed cornering, vehicle parking and driving in city conditions with heavy traffic in tight spaces, high speed lane changing would be very difficult due to vehicle's larger wheelbase and track width which brings high inertia and traction into consideration. Hence there is a requirement of a mechanism which result in less turning radius and it can be achieved by implementing four wheel steering mechanism instead of regular two wheel steering.

4-Wheel Steering System is not a new technology but it has not gained popularity over 2-Wheel Steering System even though experiments have proved that it has excellent manoeuvrability, high stability and it is a solution to oversteer/understeer. If 4-Wheel Steering is a better replacement for age old 2-Wheel Steering, why has it not replaced it yet?

**Keywords:** Understeer/Oversteer, Wheel Configurations, Four Wheel Steering, Turning radius.

## 1. Introduction

Steering is a system that is used in most type of transport to control the movement of the vehicle. Steering mechanism is the vehicle movement control system that includes few main components which are the steering wheel, the steering column, the steering rack and the vehicle wheels as shown in the figure below.

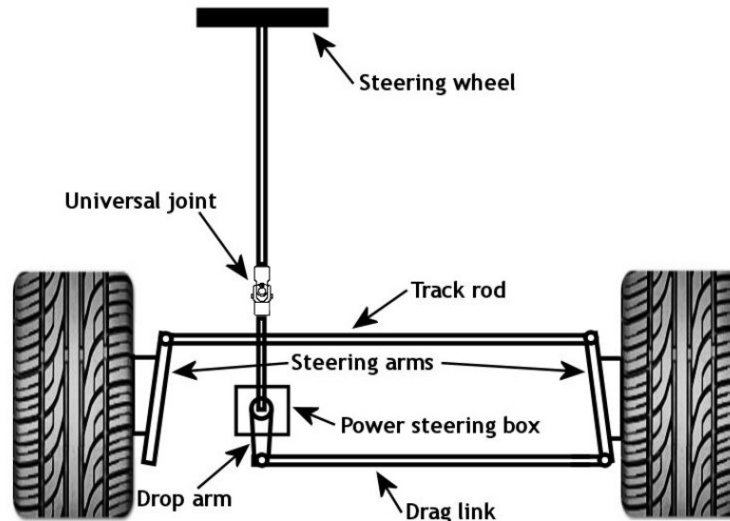

Figure 1

## 2. Problem Description

Is 4-Wheel Steering System a better replacement for 2-Wheel Steering?

If yes, why has it not replaced it yet?

## 3. Steering Principle & Components

### 3.1 Ackerman Steering Mechanism

With perfect Ackermann, at any angle of steering, the perpendicular line through the centre point of all the wheels will meet at a common point. But this may be difficult to arrange in practice with simple linkages. Hence, modern cars do not use pure Ackermann steering, partly because it ignores important dynamic and compliant effects, but the principle is sound for low speed manoeuvres.

### 3.2 Turning Radius

The turning radius or turning circle of a vehicle is the diameter of the smallest circular turn (i.e. U-turn) that the vehicle is capable of making.

Turning circle radius =  $(\text{track}/2) + (\text{wheelbase}/ \sin(\text{average steer angle}))$

### 3.3 UNDERSTEER

When the slip angle of front wheels is greater than slip angle of rear wheels vehicle understeers. Thus the vehicle goes out of the circle of steering. Most vehicle manufacturers set the vehicle profile with some understeer.

### 3.4 OVERSTEER

Over steer is defined when the slip angle of front wheel is less than the slip angle of rear wheel. This makes the vehicle move inside the circle of steer. This is a far dangerous situation than understeer.

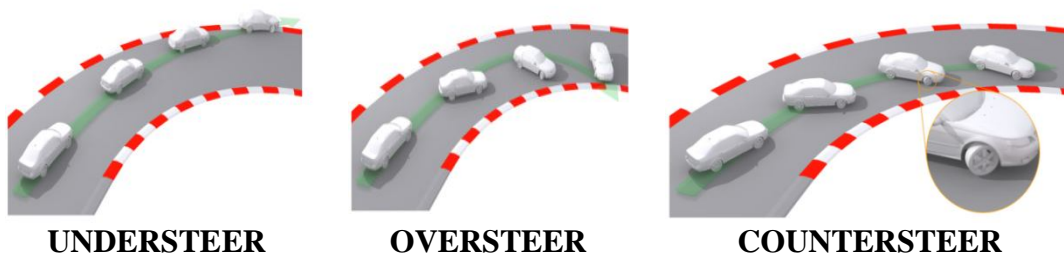

### 3.5 Neutral Steer OR COUNTERSTEER

Counter-steering can be defined as when the slip angle of front wheels is equal to slip angle of rear wheel. The vehicle follows the line with utmost stability.

## 4. Design & Understanding of 4-Wheel Steering

The idea behind four wheel steering is that a vehicle requires less driver input for any steering manoeuvre if all four wheels are steering the vehicle. As with two wheel steer vehicles, tyre grip holds the four wheels on the road. However, when the driver turns the wheel slightly, all four wheels react to the steering input, causing slip angles to form at all four wheels. The entire vehicle moves in one direction rather than the rear half attempting to catch up to the front. The vehicle responds more quickly to steering input because rear wheel lag is eliminated. To find the vehicle's turning radius 'R', we may define equivalent bicycle models as shown in Figure below for positive 4-Wheel Steering vehicles. The radius of turn 'R' is perpendicular to the vehicle's velocity vector 'v' at the mass centre 'C'.

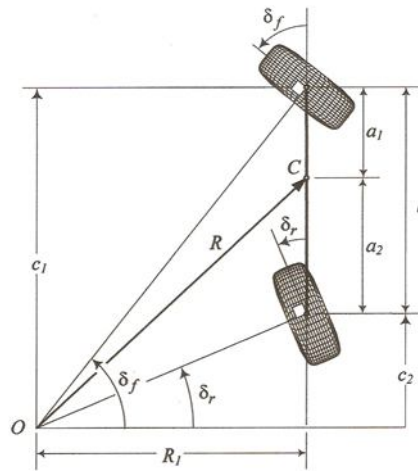

**Figure 2**

Using the geometry shown in the bicycle model, we have

.....where, 'R' is Turning Radius

—.....' ' is distance between instantaneous centre and axis of wheels

—  
\_\_\_\_\_

From the works of K. Lohith, M.S Ramaiah School of Advanced Studies it can be stated that,

Assuming standard turning radius of two wheel steering is 4.4m

Turning Radius for Four Wheel Steering is 2.596m which is found from the above equation of 'R'.

## 5. Steering Wheel Configurations

- (a) **Two Wheel Steer** : A 4-Wheel Steering System is flexible enough to work as a 2-wheel steer by restricting the rear wheel movement.
- (b) **Four Wheel Steer**: Front wheel directions are opposite to rear wheel directions. This helps to take sharp turn with least turning radius. This is done at slow speed.
- (c) **Crab Steer**: At high speed lane change, both the front and rear wheels face in same direction.
- (d) **Zero turn**: Front and Rear wheels are so aligned that the vehicle moves in a circle of "zero radius".

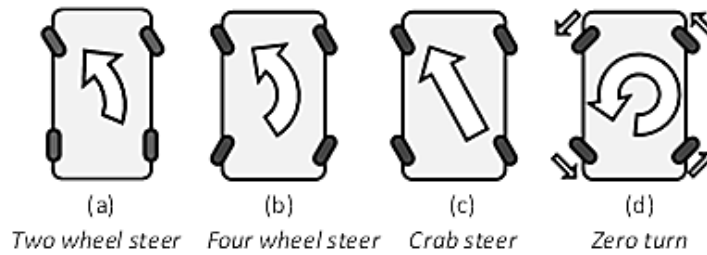

**Figure 3**

**6. Advantages**

1. Superior cornering stability.
2. Improved steering responsiveness and precision.
3. High speed straight line stability.
4. Notable improvement in rapid lane changing manoeuvres.
5. Smaller turning radius and tight space manoeuvrability at low speed.
6. Relative wheel angles and their control.

**7. Limitations**

The effect that it produces is not felt significantly at low speed or in commercial cars but in heavy vehicles like trucks and towing vans it provides significant lane changing and low speed manoeuvrability. Its mechanism is extensively complex. Although many designs have been brought forward so far, none has the right combination of simple design, low maintenance with low cost.

**8. Conclusion**

Turning Radius	Four Wheel Steer	Two Wheel Steer
By Calculation	2.59 m	4.4 m
By Experiment	2.85 m	5.75 m

Table (K. Lohith) gives the comparison between the turning radius for two wheel steer and four wheel steer by calculation and experiment. By calculation we can

conclude that there is 41.13% reduction in turning radius and by experiment it's 50.43%. The information put above clearly states that 4 Wheel Steering has many advantages and it can truly become a successful replacement for 2-Wheel steering system. But its design is so expensive that automotive manufacturers have not yet arrived at an economical solution. It is incepted in Jeep Hurricane, Lexus GS and other high end automobiles.

Thus the four wheel steering system has got cornering capability, high steering response, straight line stability, lane changing and low speed manoeuvrability. Even though it is advantageous over the conventional two wheel steering system, 4-Wheel Steering is complex and expensive. Currently the cost of a vehicle with four wheel steering is 10% more than that of conventional two wheel steering system. It is not economically viable to replace two wheel steering with 4-Wheel Steering in cars where the consumer expects more from the technology for the extra cost, but in heavy truck and towing vehicles it gives more driving advantage over cost. It is the next generation technology but with lot yet to be known. Michael Schumacher in Estoril, Portugal in 1993 tested Cosworth-powered B193. The lap times testified that if the system added any to the car's performance, it wasn't very much. It is a technology of future but not of present.

## References

- [1] H. Sakai, T. Matsuo, S. Murayama, H. Hoshino, and R. Nagashima, Utsunomiya University, Utsunomiya, Japan
- [2] Institute for Dynamic System and Controls, Steering Dynamics
- [3] K. Lohith<sup>1</sup>, Dr. S. R. Shankapal<sup>2</sup>, M. H. Monish Gowda<sup>3</sup>, Automotive and Aeronautical Engineering Department, M. S. Ramaiah School of Advanced Studies, Bangalore – 58.
- [4] Mohm. Hanif Bin Md. Yusuf, Dept. of Mechanical Engineering, Universiti Teknikal Malaysia, Melaka
- [5] Unknown, Four Wheel Steering System,  
<http://www.docstoc.com/docs/73259901/Four-Wheel-Steering-System>