

# Finite Element Analysis of Simple Butt Type Adhesive Joint Using RADIOSS

Mr. Mahesh Shivaji Kadam

*Assistant Professor, Mechanical Engineering Department  
Sanjay Ghodawat Group of Institutions,  
Atigre, Kolhapur, India*

Dr. Vivek V. Kulkarni

*Professor & Dean Academics, Mechanical Engineering Department  
Sanjay Ghodawat Group of Institutions,  
Atigre, Kolhapur, India*

## Abstract

Majority of automobile and aerospace parts, mainly their body components are joined together by different types of adhesives. So these growing needs demand the detailed study on stress concentration and strength analysis of adhesive joints. With the help of structural analysis simulations we can identify the problem areas, failure loads and solutions can be validated in computers without any expensive shop floor operations prior to any tool construction. Structural analysis simulation is also helpful at the joint design stage to decide various parameters, like material used, load applied etc. In the recent years the use of finite element analysis is increased in the strength analysis of sheet metal joints. Finite element analysis helps to analyze the process virtually.

The present investigation reports a case study of a butt type adhesive joint of similar and dissimilar metals. This joint is subjected to static tensile loading and the RADIOSS deck of Hyperworks 11.0 software package is used to carry out the analysis. The analysis result helps in depicting the effects of varying load and material used on stress induced and hence on the joint strength of metal to metal butt type adhesive joint under static tensile loading is studied in this case study.

**Keywords:** Stress concentration, Strength analysis, Butt type adhesive joints and Adhesive thickness.

## Introduction

The influence of static tensile loading on stress distribution within the adhesive joint is analyzed by finite element method. Practically Von Mises stresses are maximum at edge and decreases away from edge. Similarly shear stresses almost vanish towards the middle of the adhesive. The shear stress contribution to the Von Mises stress is significant in the bond region close to the metal plate; this in turn results in possible failure of bonding in this region. In actual practice strength of adhesion to the metal surface is stronger than the strength of the adhesive itself. That means the joint will fail in midway of adhesive instead of at the adhesive metal interface.

## Literature Review

The work of different researchers in the area of strength analysis of butt type adhesive joint is presented below, Author presented simple analytical formulae in literature to extract basic elastic material properties of adhesives subjected to tensile loading. A numerical parameter study for different combinations of adherend/adhesive materials and butt-joint geometries has been performed to investigate the influence of These parameters on the adhesive deformation. It is shown that the shape of the deformed adhesive layer essentially depends on the specimen geometry and the material

parameters of the bonded materials as well as on those of the adhesive layer. [1]

Investigator considered the mechanical behavior and failure under proportional, multi-axial loading using an instrumented, Arcan-type test. The statistical behaviour, also observed with a simple tensile test, seems to be related to the heterogeneous nature of the microstructure of the adhesive bond, which contains voids, as well as mineral particles for reinforcement. It is concluded that the statistical aspects of porosity distribution can clearly be seen to depend on several factors, such as the type of adhesive paste, the operator and the mixing process. Dispersion and distribution of porosities can explain the variability of fracture strength in mechanical testing during adhesive characterization. [2]

Researcher investigated the effect of adhesive thickness on tensile and shear strength of a polyimide adhesive. Tensile and shear tests are carried out using butt and single lap joints. And concluded that the tensile strength for butt joint decreases with increasing adhesive thickness and shear strength for single lap joint is almost constant regardless of adhesive thickness, although a lot of scatter is observed in the tensile and shear strength of polyimide adhesive. The fabricated joints using the polyimide adhesive failed in an interfacial manner regardless of adhesive thickness. [3]

Author prepared high-temperature organic adhesive by using preceramic polymer V-PMS as matrix, B<sub>4</sub>C powder and low melting point glass powder as additives, and is successfully applied to join Al<sub>2</sub>O<sub>3</sub> ceramic. The obtained adhesive exhibited outstanding heat-resistant property and bonding strength. The results indicated that, up to 600°C, the preceramic polymer and the glass additive play important role in improving the bonding strength. Above 800°C, the outstanding wetting property and chemical compatibility of B<sub>2</sub>O<sub>3</sub> formed by the oxidation of B<sub>4</sub>C are mainly responsible for the excellent high-temperature bonding strengths. [4]

Researcher presented the work on the strength and failure prediction of adhesive joints of brittle epoxy bonding of two dissimilar adherends, effects of bond thickness and scarf angle upon the strength of joints is addressed. The model for strength prediction proposed is based on three parameters as, interface corner toughness, interfacial crack, fracture toughness and interfacial toughness. It is reported that the strength of adhesive joint reduces with increasing bond thickness and scarf angle. Also shear joint specimens have higher reliability than butt and scarf joints. Although the stress singularity order at interface corner is max. [5]

Investigator followed the strategy previously developed for monotonic loadings. The crack initiation in adhesively bonded joints is analyzed, under various tensile /compression-shear cyclic loadings using a modified Arcan device with a single bonded joint designed to strongly limit stress concentrations. Experimental results, for a ductile adhesive, under cyclic loadings are presented for different load amplitudes and mean loads; they underline that the evolutions of viscous deformations and of damage depend on the loading type. [6]

## Adhesive Bonding

### A. Advantages of adhesive joints:

The various types of adhesive joints are widely used now days in automobile and aerospace industries because of its inherent advantages listed below.

It is lightweight chemical, so reduces weight of the joint as compare to riveted or bolted which adds its self weight to the joint.

Adhesive joining techniques do not require holes, as riveted or bolted joints do, which can lead to stress concentration.

Adhesives are compressible in nature which helps to damp the vibrations generated at high speed.

Different types of adhesives for different applications are available commercially at very low cost.

Some special types of adhesives are able to sustain at very high temperature and varying environmental conditions.

### B. Case study of butt type metal to metal adhesive joint:

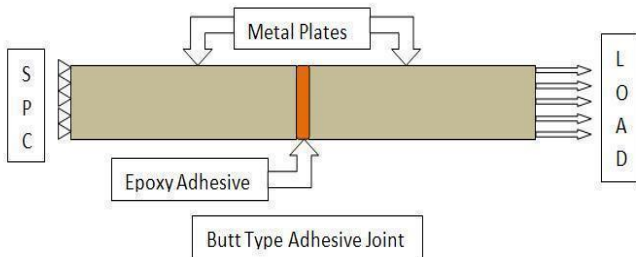

Figure 1: Butt type tensile joint configuration.

Figure 1 shows the butt type tensile joint configuration used for the strength analysis in simulation with RADIOSS. The Structural Epoxy Adhesive is used to join two metal Plates.

Table 1: Material Properties

Material Used	Modulus of Elasticity (E) in MPa	Poisson's Ratio ( $\nu$ )
Structural Epoxy	1.085e3	0.38
Aluminium	6.895e4	0.33
Mild Steel	2.100e5	0.30

The material properties of the metal plates i.e. Aluminium and Mild Steel and the adhesive used i.e. Structural Epoxy are as shown in Table 1. Following is the detailed procedure adopted for the Finite Element Analysis.

### Creating the 3D model-

The 3D model of the component is created in CATIA V5 R16 environment as shown in Figure 2. The model is created in

two easy steps. First one plate is created and assigns Aluminium or Mild Steel material to it. Then create the second plate and assign the Aluminium or Mild Steel material to it. These materials will decide the variation of material combinations in joint.

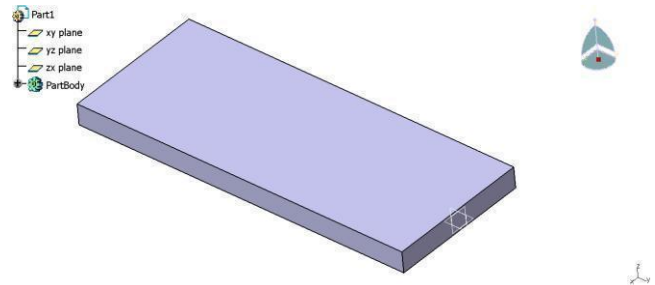

Figure 2: 3D model of the Metal Plate

### Hypermesh 11.0 is opened in user profile-

To open **RADIOSS**, click Start then **HyperMesh**. A User Profiles window should pop up, as shown in Figure 3. If the User Profiles window doesn't pop up go to Preferences then click on User Profiles. Under the Application drop down list select **HyperMesh** then select **RADIOSS Bulk Data** deck and click on OK.



Figure 3: User Profile of Hyperworks

### The 3D model is imported in HyperMesh-

To import 3D model, go to File and click on Import. Then for the Import Type choose Geometry and for the File type choose Auto Detect. Then click the yellow folder icon and browse to where the CatPart file is located and click on Import then Close. The imported geometry i.e. two plates will look as shown in Figure 4.

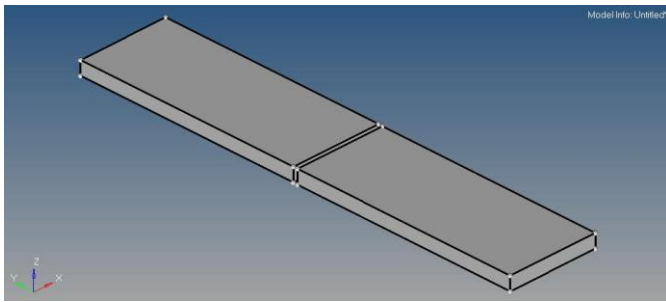

Figure 4: Imported 3D model of the metal plates

**Mesh the plates-**

Use create-2D Automesh option to mesh both plates one by one, enter the following values to define the mesh.

Element Size: 1.5

Mesh Type: quads

Click on mesh button. A uniform mesh will be generated. The meshed component will be seen as shown in Figure 5.

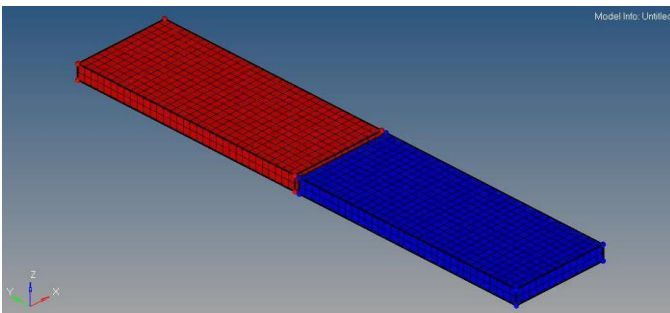

Figure 5: Meshed Plates

**Create adhesive connector-**

For creating adhesive first of all hide one meshed plate then select some of the elements on end plate. Then click on elems and select by face to select all elements on that face to join by adhesive. For components click on comps and select Plate\_01 and Plate\_02. In type of connector select adhesives and enter the value of density as 3 under (T1+T2)/2 options with tolerance of 10. An adhesive will be generated between these two plates as shown in Figure 6.

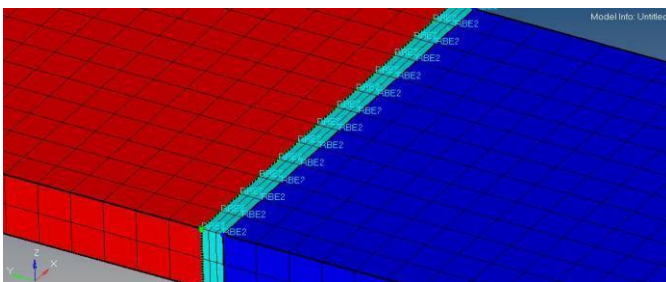

Figure 6: Adhesive Connector

**Apply boundary conditions-**

Nodes on extreme right face of the blue plate are selected, and constrain their all degrees of freedom with a zero value. This constrain comes under SPC load collector. Then select the

nodes on extreme left face of the red plate and apply an axial load on each node in Y direction. The model under constraints is shown in Figure 7.

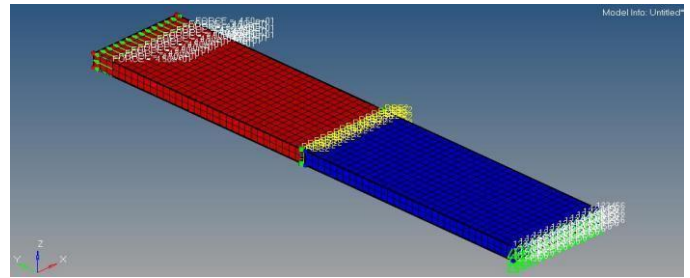

Figure 7: Joint with Boundary Conditions

**Model is checked and analysis is run-**

After completing all boundary conditions and applying all loads, click on Analysis tab and save the file as Adhesive\_Joint.fem and click on Radioss. It will run the solver file and displays that analysis is completed; the prompt display is shown in Figure 8.

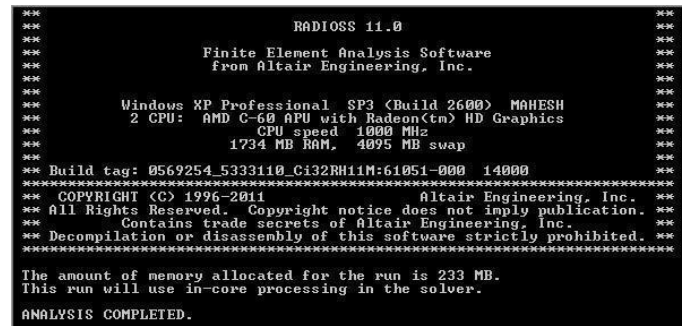

Figure 8: Solver Run prompt

**View the results-**

To see the results click on Hyperview in Analysis tab. We will get the required results such as displacements and elemental stresses (Von-Mises and maximum shear stresses) in Hyperview environment. Figure 9 shows the magnitude of displacement for the joint of 1 mm adhesive thickness under static tensile loading.

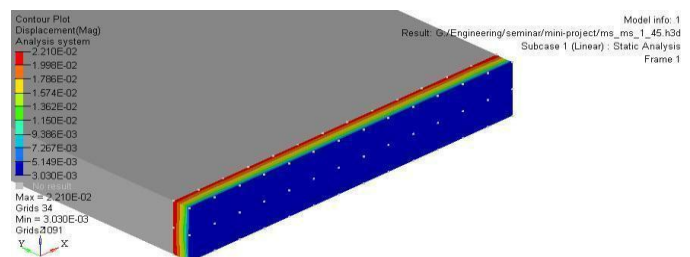

Figure 9: Magnitude of Displacement

Now following are the images which displaying the results for the elemental stresses obtained at joint consisting of simple Von Mises stresses in Figure 10 and simple maximum shear stresses in Figure 11.

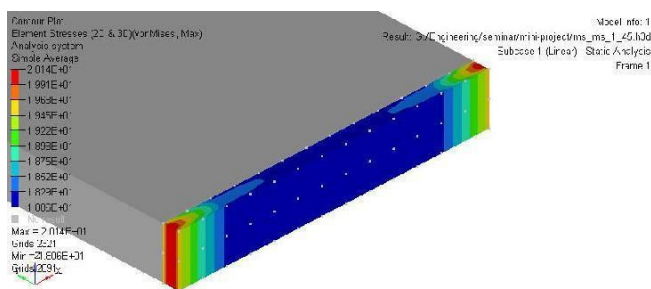

Figure 10: Simple Von Mises Stresses

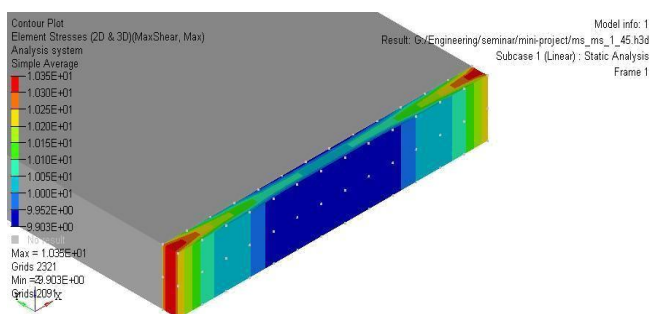

Figure 11: Maximum Shear Stresses

**FEA Results**

Above procedure is repeated for different loads at adhesive thickness of 1mm and determine the respective stresses. The values obtained by analysis are entered into Table 2. The graph showing relation between load applied and stresses induced is shown in Figure 12 for MS-MS joint having adhesive thickness of 1mm.

As per Juliade Castro San Roman, mentioned in his technical report CCLab2000.1b/2 on “Experiments on Double Lap Joints with EP, PU & ADP Adhesives”, the Epoxy adhesives offer a tensile strength of  $38.1 \pm 2.6$  MPa.

The FEA process is also repeated for different material combinations of metal plates used and the load applied is varied to determine the different stress values. The values are then entered into a tabular form and plot a graph for each table. Table 3 and Table 4 are for AL to AL and MS to AL joint respectively, while they are presented in graphs by Figure13 and Figure 14.

Table 2: Load & Stress Values for MS to MS joint

Trial No.	Load Applied in KN	Elemental Stress in MPa	
		Von Mises	Max Shear
1	1.890	20.14	10.35
2	2.100	22.38	11.50
3	2.310	24.62	12.65
4	2.520	26.86	13.80
5	2.730	29.09	14.95
6	2.940	31.33	16.10
7	3.150	33.57	17.24
8	3.360	35.81	18.39
9	3.570	38.05	19.54
10	3.780	40.28	20.69

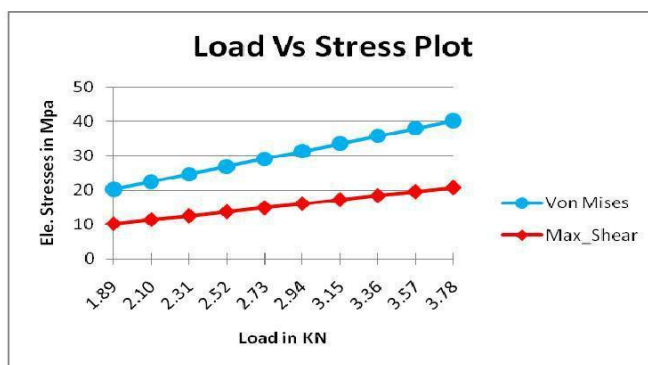

Figure 12: Load Vs Stress Plot for MS-MS Joint

Table 3: Load & Stress Values for AL to AL joint

Trial No.	Load Applied in KN	Elemental Stress in MPa	
		Von Mises	Max Shear
1	1.890	21.04	10.81
2	2.100	23.38	12.01
3	2.310	25.72	13.22
4	2.520	28.06	14.42
5	2.730	30.40	15.62
6	2.940	32.74	16.82
7	3.150	35.07	18.02
8	3.360	37.41	19.22
9	3.570	39.75	20.42
10	3.780	42.09	21.63

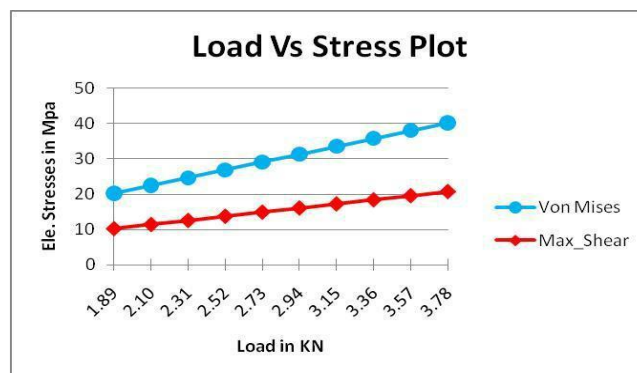

Figure13: Load Vs Stress Plot for AL-AL Joint

Table 4: Load & Stress Values for MS to AL joint

Trial No.	Load Applied in KN	Elemental Stress in MPa	
		Von Mises	Max Shear
1	1.890	20.61	10.59
2	2.100	22.90	11.77
3	2.310	25.19	12.94
4	2.520	27.48	14.12
5	2.730	29.77	15.30
6	2.940	32.06	16.47
7	3.150	34.35	17.65
8	3.360	36.65	18.83
9	3.570	38.94	20.00
10	3.780	41.23	21.18

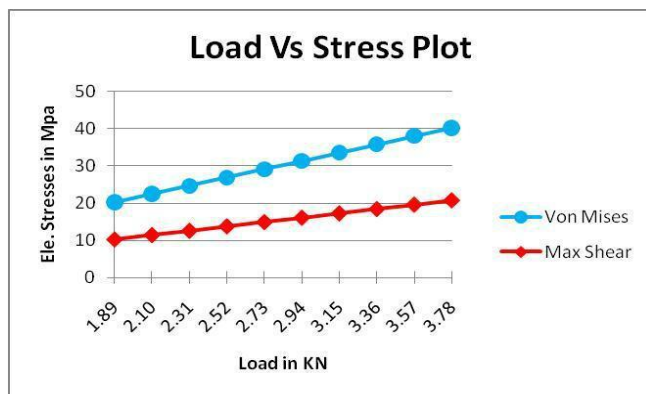

Figure 14: Load Vs Stress Plot for MS-AL Joint

### Comparison of Results

Finally the FEA results for different material combinations are compared with each other. The Von Mises stresses obtained for these combinations are plotted on a graph in Figure 15 and maximum shear stresses are plotted on a graph shown in Figure 16. The values for these graphs are taken from Table 2 to Table 5.



Figure 15: Von Mises Stresses Comparison Plot

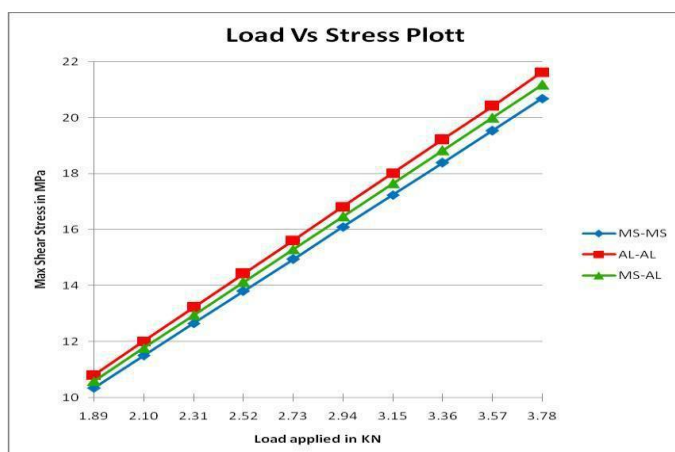

Figure 16: Maximum Shear Stresses Comparison Plot

### Conclusion

Following conclusions are drawn from the analysis of the case study.

1. It is found from the analysis that, for the same adhesive thickness and material properties the stress induced is directly proportional to the load applied.
2. As stress induced has negative effect on the joint strength, the strength of the joint is decreased with the increase in the applied load.
3. More is the soft material of the metal plates; less is the adherence between adhesive and plate and simultaneously maximum are the elemental stresses induced in that joint and adhesive.
4. It is observed that the finite FEA predictions for Von Mises stresses and maximum shear stresses are different for different material combinations, which indicates direct proportion between modulus of elasticity and strength of the joint.
5. The Von Mises stresses and maximum shear stresses obtained at the same load for MS-MS joint are less as compared to MS-AL and AL-AL joint, thus MS-MS joint is strongest bond out of three material combinations. While for AL-AL joint the stresses induced are maximum therefore this bond is weakest amongst the three material combinations.

### REFERENCES

- [1] Andreas Ochsner, Michal Stasiak, Gennady Mishuris, Jose' Gra'cio; "A new evaluation procedure for the butt-joint test of adhesive Technology : Determination of the complete set of linear elastic constants"; International Journal of Adhesion & Adhesives 27 (2007) 703-711.
- [2] Gregory Bresson, Julien Jumel, Martin E.R. Shanahan, Pierre Serin; "Strength of adhesively bonded joints under mixed axial and shear loading"; International Journal of Adhesion & Adhesives 35 (2012) 27-35.
- [3] Kimiyoshi Naito, Mutsumi Onta, Yasuo Kogo; "The effect of adhesive thickness on tensile and shear strength of polyimide adhesive"; International Journal of Adhesion & Adhesives 36 (2012) 77-85.
- [4] Xiaozhou Wang, Jun Wang, Hao Wang; "Performance and structural evolution of high-temperature organic adhesive for joining Al<sub>2</sub>O<sub>3</sub> ceramics"; International Journal of Adhesion & Adhesives 45 (2013) 1-6.
- [5] Mohd Afendi, M. S. Abdul Majid, Ruslizam Daud, A. Abdul Rahman, Tokuo Teramoto; "Strength prediction and reliability of brittle epoxy adhesively bonded dissimilar joint"; International Journal of Adhesion & Adhesives 45 (2013) 21-31.
- [6] D. Thevenet, R. Creachcadec, L. Sohier, J. Y. Cognard; "Experimental analysis of the behavior of adhesively bonded joints under tensile/ compression-shear cyclic loading"; International Journal of Adhesion & Adhesives 47 (2013) 15-25.
- [7] Juliade Castro San Roman, A technical report "CCLab2000.1b/2" on "Experiments on Double Lap Joints with EP, PU & ADP Adhesives".