

“Performance analysis of Next Generation Network Router using MATLAB simulator.”

Pallavi R. Patil,

Research scholar, Electronics Engg. Dept., D. Y. Patil College of Engg. & Tech. Kolhapur, Maharashtra, India

Prof. Dr. Mrs. S. V. Sankpal,

Professor, Electronics Engg. Dept., D. Y. Patil College of Engg. & Tech. Kolhapur, Maharashtra, India

Prof. Santosh D. Bhopale,

Research scholar, Electronics Engg. Dept., Tatyasaheb Kore Institute of Engg. & Tech. Warananagar, Maharashtra, India

Abstract: Next generation Networks (NGN) are required to support the seamless delivery of voice, video and data with high quality. The advantages of the proposed method, in terms of QoS gains, are demonstrated through modeling of the main QoS parameters. Among the many issues faced by NGN is the quality of service (QoS) issue as would be with any IP based network; which is measured in terms of network latency, throughput, packet delay variation, packet loss etc. Several techniques try to solve this issue in a best effort environment. Multi Protocol Label Switching (MPLS) was found to be the technology which seems to solve the problem better than others primarily due to its traffic engineering capabilities. In this proposed work we identify the challenges that need to be addressed in designing a three level core which consists of policy making, packet queuing and forwarding and resource utilization itself concerning the high performance, QoS supported transport services, it is not sufficient that only the traffic transport under a single domain. A DiffServ support for MPLS was only natural as there are certain resemblances between the two the most important being that traffic classification in case of both DiffServ and MPLS takes place at the ingress of their respective domains. Using this combination we get more control in providing the quality of service where priorities are to be given to some applications over the others.

Keywords: NGN, QoS, admission control, transport resource, IP/MPLS.

Introduction

Next Generation Networks are packet-based with capabilities to support multiple broadband networks and provide end-to-end Quality of Service (QoS) guarantees across multiple access networks.

However, each technology implements its proprietary QoS solutions to satisfy its own network requirements. They define QoS classes based on their standard specifications which makes right mapping of QoS classes over heterogeneous networks a difficult task. Consequently, QoS parameters could seriously be affected at destination as a result of cumulative incorrect QoS mapping conversions. Providing QoS to the 5G network is contingent upon evolution of heterogeneous networks. A challenging task is how to transfer the QoS parameters over different networks to the end user in a unified environment. One possible solution is establishing a common interface among different types of network that can translate the QoS requirements from one type of network to the other. QoS means to meet out certain requirements or guarantees to a particular traffic which might include giving preferential treatment to some traffics over others e.g. voice and video traffics are more sensitive to delay and packet delay variation and loss as compared to file transfer or email. QoS can be provided by resource over-provisioning which in many cases is not possible or by network management which is the task of the QoS techniques. ATM was the first technology for providing QoS [2] but has the disadvantage of a large overhead (5 bytes to 48 in an ATM cell). IntServ provides guaranteed services but has scalability problems due to large number of RSVP messages going on in the network to reserve the resources for each flow separately [2]. DiffServ is the other way round having good scalability (class based QoS rather than flow based) but only provides coarse quality of service; providing only the preferential treatment to

some traffic classes over the others [3]. Multi Protocol Label Switching (MPLS) is a new emerging technique where the packets are fast switched across the interfaces of a router i.e. the layer 2 functionality using 32-bit labels instead of routing by IP header which is a comparatively slow process. Besides this, Traffic Engineering (TE) is also possible through MPLS which leads to balancing the network traffic and efficient use of network resources, thereby making it possible to achieve higher network throughput. MPLS on the other hand is much like DiffServ in that the service differentiation takes place at the ingress only and all routing decisions are taken there.[3] Next-generation network (NGN) is a new concept commonly used by network designers to depict their vision of future telecommunications networks. Even if the required resources are successfully reserved, the delay, jitter, and other QoS parameter values may be out of range because of the interference of other traffic. [5] Another thing is that NGN should have the interoperability with the existing networks. The important issues that need to be addressed in NGN are reliability, addressing (given its heterogeneous nature), security and quality of service(QoS) which has been discussed in this paper. Various technologies available for providing QoS are ATM, DiffServ, IntServ, and MPLS. MPLS was found to be the most promising technology with regards to QoS in NGN primarily due to its traffic engineering capabilities. However MPLS DiffServ combo gives us more control in providing QoS as has been shown in the simulations conducted.[3] MPLS is a packet forwarding scheme in which the packets are assigned labels and based on these labels forwarding decisions at routers are taken instead of the IP address contained in the IP header. All the routing decisions are taken just once that is when a packet enters the MPLS network. This approach to QoS management will be maintained in 5G networks as well. QoS management mechanisms in 5G networks should provide video and VoIP traffic prioritization towards Web search traffic and other applications tolerant to quality. The service of streaming video transfer without buffering is very sensitive to network delay, so one of the most important parameters that determine QoS requirements is the total packet delay budget (PDB) The emergence of 5G networks in the market in 2020 will be focused on a significant improvement of

characteristics of mobile networks, including quality of service.

Literature survey

Cherif Ghazel, Leila Saïdane, in “Satisfying QoS Requirements in NGN Networks using an Optimized Resource Control and Management Method” proposed an extension of RTCP called SubRTCP that enabled middle nodes to monitor an RTP session and to report the result using the same RTCP session. Cherif Ghazel and Leila Saïdane proposed and demonstrate an efficient NGN QoS-Aware resource and admission control and management methodology which guarantees the QoS requirements. In this paper, we proposed a QoS resource-based admission control method which guarantees QoS for the transport of real-time multi-service traffic in next generation networks. It is applied at the edge level under the control of the RACM as a basis component for the proposed large scale QoS guarantee architecture. More importantly the proposed method ensures that QoS guarantees are always provided to incoming and already established sessions. In this paper, we proposed a QoS resource-based admission control method which guarantees QoS for the transport of real-time multi-service traffic in next generation networks. This QoS control method is based on service differentiation using pre-emptive and non pre-emptive priority disciplines.

Xi Zhang, Wenchi Cheng, and Hailin Zhang, “Heterogeneous statistical QoS provisioning over 5G Mobile Wireless Networks” explained that the 5G mobile wireless networks are expected to provide different delay-bounded QoS guarantees for a wide spectrum of services, applications, and users with extremely diverse requirements. Since the time-sensitive services in 5G multimedia wireless networks may vary dramatically in both a large range from milliseconds to a few seconds and diversity from uniform/constant delay-bound to different/variable delay-bound guarantees among different wireless links, the delay-bound QoS requirements for different types of services promote the newly emerging heterogeneous statistical delay-bounded QoS provisioning over 5G mobile wireless networks, which, however, imposes many new challenging issues not encountered before in 4G wireless networks. To overcome these new challenges, they proposed a novel heterogeneous statistical QoS provisioning architecture for 5G mobile wireless networks. they develop and analyze the new heterogeneous statistical QoS system model by applying and extending the effective capacity theory.

Umer Mushtaq Mir, Ajaz H. Mir, Adil Bashir, “DiffServ-Aware Multi Protocol Label Switching Based Quality of Service in Next Generation Networks” described that Next Generation Networks (NGN) is the future of communication which will provide each and every service over the same network. The network will only act as a bit highway or a packet highway, forwarding packets of each and every kind over the internet protocol or IP. Among the many issues faced by NGN is the quality of service (QoS) issue as would be with any IP based network; which is measured in terms of network latency, throughput, packet delay variation, packet loss etc. Several techniques try to solve this issue in a best effort environment. Multi Protocol Label Switching (MPLS) was found to be the technology which seems to solve the problem better than others primarily due to its traffic engineering capabilities. Besides priorities can be given to some traffic using DiffServ aware MPLS as certain applications require so. So it is concluded that MPLS over DiffServ will provide the quality of service in NGN.

Yasusi Kanada, “Policy-based End-to-End QoS Guarantee Using On-Path Signaling for Both QoS Request and Feedback”, proposes in his research as the QoS parameters in reservation and feedback messages should coincide and the mechanisms for these two can be similar. Therefore, we designed a protocol called SNSLP for both QoS request and feedback messages. SNSLP was implemented on the top of RTCP for both an experimental network with policy-based QoS control and a voice application called voiscap. In addition, an implementation method using routers without an SNSLP stack for policy-based routing is described and the result of implementation is reported. To achieve end-to-end QoS, applications must declare QoS parameters to be guaranteed or send a request resource reservation to the network. The Resource Reservation Protocol (RSVP) [Bra 97] was developed for this purpose. RSVP allows applications to communicate implicitly with the network (nodes) for reserving communication bandwidth and several other network resources. The Resource Reservation Protocol (RSVP) [Bra 97] was developed for this purpose. To meet the request, the network nodes or servers must receive and forward RSVP messages and configure the nodes to reserve resources for the flow.

Boyoung Rhee, Sungchol Cho, Jin Xianshu, Sunyoung Han, “QoS-Aware Router Combining Features of Conventional Routing and Flow-aware Routing Based on Resource Management over NGN” explained RACF (Resource and Admission Control Functions) provides QoS control functions including a resource reservation, admission control and gate control in order to get the desired QoS for

communication and permission to access needed resources. RACF is composed of PDF (Policy Decision Function) and TRCF (Transport Resources Control Function). TF (Transport Functions) is the set of functions that support the transmission of media information and control information. QoE means end-to-end QoS from the point of view of a subscriber, and it makes subscribers be served with suited services for each one. The router in this paper sets itself up with QoS policies, and communicates with TRCF in order to receive QoS policies, and to report the data state which this router collects and analyzes. This mechanism could be used in any network services for guaranteeing QoS such as real-time services. In addition, one main aspect of NGN services is to grasp the receiver’s situation and feeling of satisfaction about services in order to analyze and provide QoE (Quality of Experience).

System Diagram

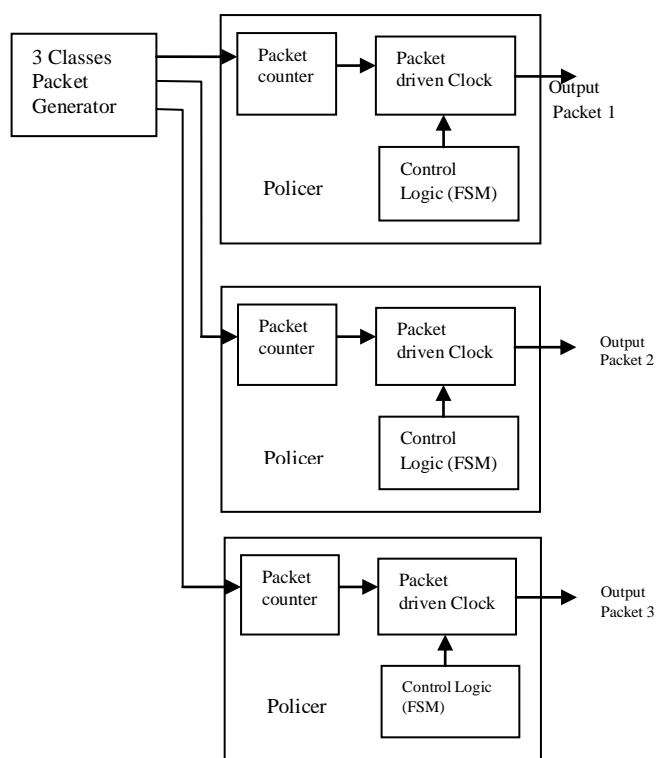

Figure 1: System Diagram for simulation

Explanation: In the first block 3 class packet classifier three high density signals are generated by time based entity generator and given to the first in first out (FIFO) queue. The queue will provide the buffering as required in the transmission as per the traffic conditions. The three signals then multiplexed

and given to the packet counters. At packet counter signal converted to bits and packet and then gives the count of packets, packets/sec and Gigabits/sec. Then these three different signals with high density are given to policer where different policies are defined in the charts as logic for controlling with packet driven clock. Here in the first block the bandwidth is allocated as 50%, 25% and 25% for channel of traffic and the different policies as required are applied on the signals in policer, and performance of the signal with respect to the confirmed packets and unconfirmed packets is analysed.

MPLS: MPLS got its name because it works with the IP, ATM, & frame relay network protocols. It was created in the late 1990's to avoid having routers waste time by having to stop & look up routing tables. MPLS is a type of data carrying technique for high performance telecommunication networks that directs data from one network node to the next based on short path labels. MPLS is a packet forwarding scheme in which the packets are assigned labels and based on these labels forwarding decisions at routers are taken instead of the IP address contained in the IP header. All the routing decisions are taken just once that is when a packet enters the MPLS network. A four octets label is assigned when the packet enter into the network. The assignment of a packet to what is called an FEC (Forwarding Equivalence Class) is done just once when the packet enters in the MPLS network at the ingress node. The label is inserted between the layer 2 header and the IP header. Existing protocols are extended to enable to piggyback on MPLS labels. MPLS on the other hand is a frame forwarding mechanism based on the application, treatment and exchange of labels that provide efficient forwarding of traffic within the MPLS domain. MPLS is not designed to replace IP or IP routing protocols but instead works in conjunction with IP routing protocols to provide a simple and less process intensive approach for determining the next best hop.

GMPLS: (Generalized Multiprotocol Label Switching), also known as Multiprotocol Lambda Switching, is a technology that provides enhancements to Multiprotocol Label Switching (MPLS) to support network switching for time, wavelength, and space switching as well as for packet switching.

RACF: The Resource Admission Control (RAC) is a concept introduced into the Next Generation Network (NGN). It resides between the service control layer and the bearer transport layer. It hides the details of transport network to the service layer to support the separation of service control from transport function. It detects the resource status of transport network to secure a correct and reasonable usage of transport

network resources. This accordingly ensures there are sufficient resources available to guarantee the appropriate level of Quality of Service (QoS) and avoid bandwidth and service stealing.

Results

In this section, we shall discuss the development of simulation scenarios consisting of modeling and evaluating the main QoS parameters over an NGN transport network based-MPLS and controlled by a resource and admission control and management layer.

class	Confirmed bits	Non-confirmed bits
C1	1921	1961
C2	957	984
C3	957	984

Table 1: Proposed Policer outcome

As listed in Table 1, for the various simulations scenarios, we generated Real Time traffic (RT) as C1, C2 and C3 traffic, Confirmed bits by resource reservation as connection-oriented data traffic and non confirmed bits over an NGN transport network based IP/MPLS and controlled by the proposed method.

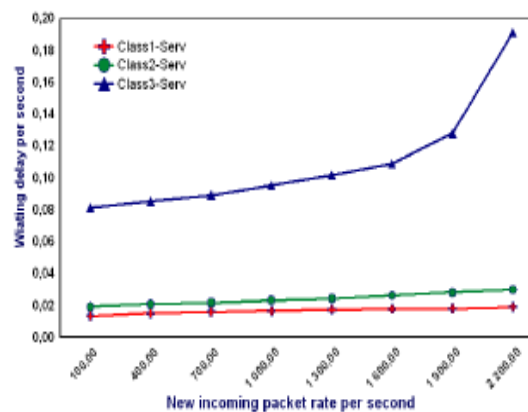

Fig 2. Delay Variations based on arrival packet rate

Fig. 2 displays the average delay variation as a function of the arrival rate. The y-axis represents the packet waiting delay per second, while the x-axis represents the incoming packet rate per second. According to different periods of observation, we can deduce that the variation of the waiting delay (QoS criteria) especially for low priority traffic closely

depends on the arrival rate of different categories of services. Accordingly, we can determine the exact moment when the admission control shall intervene and make the decision to protect the QoS offered to priority incoming and already established services.

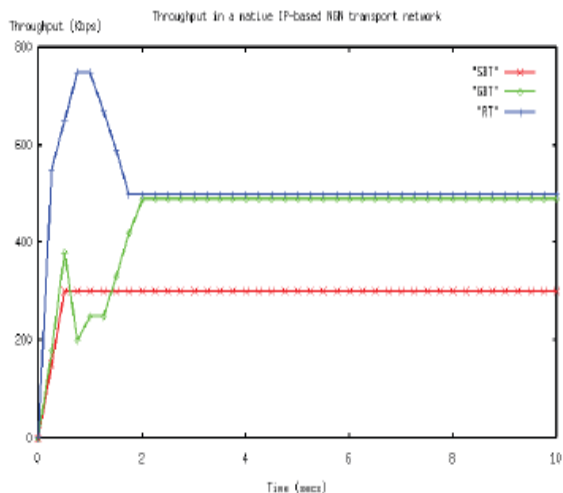

Fig 3. Throughput in a native IP-based NGN

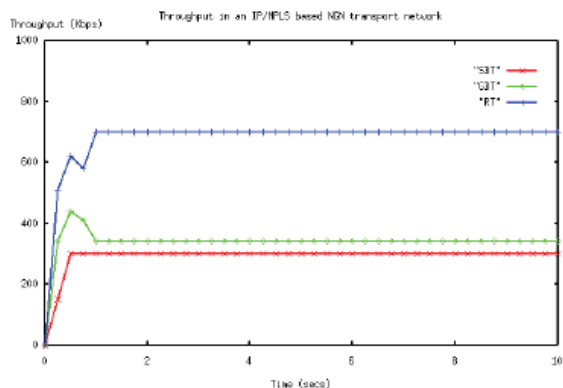

Fig. 4 Throughput in an IP/MPLS-based NGN network under the control of the RACM

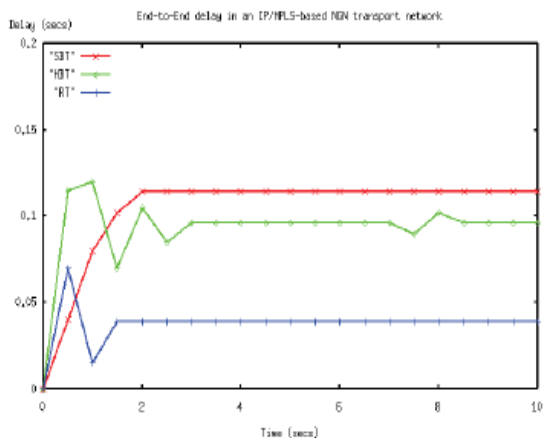

Fig. 5: Delay and jitter over an IP/MPLS-based NGN transport network under the control of the RACM

In view of Fig. 4 and Fig. 5, we observe that an IP/MPLS based NGN transport network under the control of the Resource and admission control provides “better” QoS support for real time traffic. Hence, this network architecture has the capacity to satisfy the expected real-time traffic needs, such as the required throughput and lower jitter and packet loss. It has “simpler” core functionalities since computationally expensive processing is pushed to the edge level. This results in better QoS guarantees and efficient network management, and justifies the choice of MPLS in the NGN transport level.

Conclusion

In this work a policer for better QoS with resource-based admission control method and MPLS which guarantees QoS for the transport of real-time multi-service traffic in next generation networks. This QoS control method is based on service differentiations. The control of the RACM as a basis component for the proposed large scale QoS guarantee architecture. More importantly the proposed method ensures that QoS guarantees are always provided to incoming and already established sessions. It also allocates resources in an accurate and reliable manner and improves the control and transport network scalability and resilience. We assessed the performance of the proposed method by numerically simulating and evaluating the relationship between the network capacity and the QoS requirement.

References

- [1] Cherif Ghazel, Leila Saïdane, “Satisfying QoS Requirements in NGN Networks using an Optimized Resource Control and Management Method” IEEE Proceeding 978-1-4799-8784 September 2015.
- [2] Xi Zhang, Wenchi Cheng, and Hailin Zhang, “Heterogeneous statistical QoS provisioning over 5G Mobile Wireless Networks”, IEEE Network Magazine 0890-8044 Nov/Dec 2014.
- [3] Umer Mushtaq Mir, Ajaz H. Mir, Adil Bashir, “DiffServ-Aware Multi Protocol Label Switching Based Quality of Service in Next Generation Networks”, IEEE Proceeding 978-1-4799-2572 August 2014.
- [4] Yasusi Kanada, “Policy-based End-to-End QoS Guarantee Using On-Path Signaling for Both QoS Request and Feedback”, IEEE sponsored ICOIN 2008, Korea, Jan 2008.
- [5] Boyoung Rhee, Sungchol Cho, Jin Xianshu,

Sunyoung Han, “ *QoS-Aware Router Combining Features of Conventional Routing and Flow-aware Routing Based on Resource Management over NGN*”, IEEE Computer Society ICAINA 2009 978-0-7695-3639-Feb 2009.

- [6] Gianmarco Panza, Sara Grilli, EsaPiri, JanneVehkaperä, “*QoS provisioning by cross-layer feedback control*” IEEE 978-1-4799-8030-7/14 ©2014.
- [7] Gordana Gardasevic, Dejan Stjepanovic, Aleksandar Damljanovic, Dejan Cvijanovic, “*A SOA-based Framework for Cross-layer QoS Adaptation in Next Generation Networks*”, IEEE 978-1-4673-0012-4/11 ©2011.
- [8] Alex Vallejo, Agustín Zaballos, Josep Maria Selga, Jordi Dalmau, “*Next-Generation QoS Control Architectures for Distribution Smart Grid Communication Networks*” IEEE Communications Magazine May 2012.
- [9] Xiaoling Sun, “*Research on QoS of Next Generation Network Based on MPLS*” IEEE International Conference on Information Science and Technology Wuhan, Hubei, China; March 23-25, 2012
- [10] Angel Gomez-Sacristan, Victor M. Sempere-Paya, Miguel A. Rodriguez-Hernandez, “*Virtual Laboratory for QoS Study in Next-Generation Networks With Metro Ethernet Access*” IEEE Transactions on education, vol. 59, No. 3, August 2016.
- [11] ArvindKandhalu, RangunathanRajkumar, “*QoS-Based Resource Allocation for Next-Generation Spacecraft Networks*”, IEEE 1052-8725/12 © 2012