

# Vehicle Performance Monitoring and Tracking system for Public Transport

**Ms. Supriya Satish Chougule,**

*Department of Electronics Engineering,  
Dr. J.J.Magdum College of Engineering, Jaysingpur,  
Maharashtra, India.*

**Dr. Mrs. Shubhangi B.Patil,**

*Department of Electronics Engineering,  
Dr. J.J.Magdum College of Engineering, Jaysingpur,  
Maharashtra, India.*

## Abstract

This paper illustrates the performance of remote vehicle and allows the better monitoring of various parameters of the vehicle while long distance travels from office station. The system has overcome many of the bottlenecks of private as well as public transport systems by means of providing the real time continuous monitoring of vehicles. This automatically minimizes transportation problems such as malfunctioning of accounts, technical faults in vehicle, inhuman activities and accidents. By this, service providers may get a relief as it has solved the major concern of passenger safety. This paper has proposed to design a vehicle tracking system that works using GPS and GSM technology, which would be the cheapest source of vehicle tracking and it would work as anti-theft system. The system provides the exact location on the map as well as shows the corresponding values of faults along with date, time & respective latitude longitude. These records are available on the GUI at the office end which can be maintained if required. By all this, above system claims the better solution over almost all problems faced by the transport systems.

## Keywords:

GPS, GSM, GUI, Transmitter section, Receiver Section, Sensors.

## Introduction

The successful functioning and development of the road transport enterprises within a market economy requires a sound approach to the formation of the innovation policy. The main concern in front of private as well as public transport services is safety & comfort of passengers [1]. The existing private & public travelling services still use traditional ways. Due to lack of facilities, passengers & transport services has to go through many problems. Sometimes passengers have to face serious bottlenecks [2] when there are technical faults in the vehicle at the remote places. One of the major problems is the accident. When a vehicle with full of passengers meets an accident & passengers gets seriously injured that time it's become very

difficult to get this information to their relatives [3]. Many times victims have to lose their lives due to delay in further primary health facilities. Existing transport services are facing this problem till today. It may be the thing that some unpredicted technical faults in the vehicle cause accidents. Another serious issue is the malfunctioning. Employees who use the vehicle can provide the fake accounts to owner for money. This is the unsolved headache for transport services [4]. Security of passengers from negative resources in society has become the most critical issue nowadays as there is a high risk to carry responsibility of number of passenger lives at the same time [5]. Being the private services it is not possible to provide security against inhuman activities. So from all this it can be easily concluded that existing services are not able to satisfy basic requirements of passengers of this era.

By considering today's need, private transport services coming forward to use technologies to solve problems. This system introduces much of the solutions over above discussed problems at lower possible cost. This system is divided into 2 parts i.e. in vehicle unit & base unit. The vehicle is equipped with different sensors to evaluate its performance [4]. Temperature sensor detects the vehicle engine performance as well as external difficulties of vehicle. Metal sensor provides security against terrorism activities and pressure sensors detects accidents. Fuel sensor provides information about fuel content. System uses GPS [5] i.e. global positioning system to get the exact location & time of moving vehicle in terms of longitude & latitude. System is also atomized with voice messenger. Display is provided to show monitoring parameters in vehicle. Global system for mobile communication (GSM) technology is used to send & receive information in between vehicle and central office continuously [5]. On the office side the map of the vehicle route is provided which is designed by using graphical User Interface (GUI) to show the exact position on the roadsides. Vehicle performance parameters get monitored on display on the office side continuously. Alarm indicated that vehicle is in danger so that further controlling action is decided as early as possible. In this way, system overcomes much of the problems faced by transport services.

## Methodology:

The **objective** of this project includes

- 1) Sensing five different parameters of remote vehicle.
- 2) Display those parameters over office side as well as vehicle side.
- 3) Send those parameters over Global System for Mobile network from vehicle to office side.
- 4) Trace the values of latitude and longitude of vehicle through the Global Positioning System.
- 5) Receive the parameter values and position values from vehicle and display on LCD at Office side.
- 6) Keep a record of each parameter n position on computer in the text format through GUI.
- 7) Monitor the track of vehicle over the map at the office end.

To reach these objectives sharply, the project mainly parted into two sections as Transmitter section & receiver section. Transmitter section is to be the part of remote vehicle and receiver section is fitted at the office end

### i) Block Diagram of Transmitter section

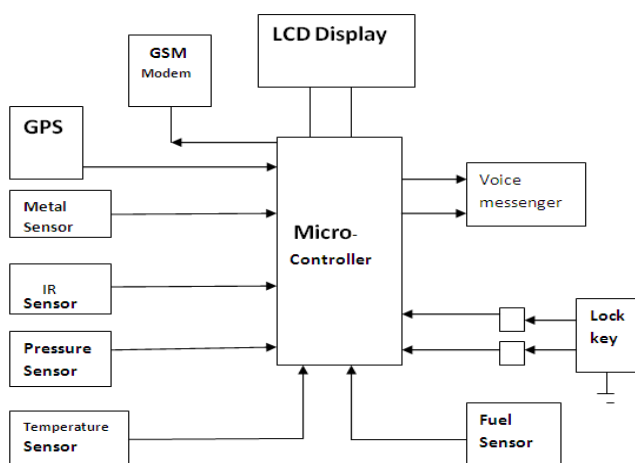

Fig.1 Transmitter

### 1] MCU: (Microcontroller unit)

It is the heart of system. All the controlling functions, data transmitting function are done by this unit. Microcontroller is the cheapest resource available for this system. Microcontroller 89c51, 89s51, 89c52 or 89s52 can be used here which are easily available in the market. Following functions will be carried out by microcontroller unit.

1. Check whether any sensor is active or not if active then do not allow ignition & inform the fault to monitoring or office station via sms.
2. Data from GPS will be received by MCU & send to monitoring or receiver station via sms.
3. To control the voice unit, activate it to announce the performance parameters when fault is detected. This voice unit can be modified to announce extra facilities while travelling such as announcement of routine instructions.

### 2] GSM module:-

GSM SIM 808 is used as a media for communication between vehicle & server. Server will be informed time to time about status of vehicle via SMS. AT commands will be used. SIM 808 is integrated with high performance GSM/GPRS engine. SIM 808 has 68 SMT pads and provides hardware interfaces between the module and customers' Boards. It has following facilities.

- I. Supports 4\*4\*2 keypads
- II. One full modem serial port.
- III. One USB, the USB interfaces can be debug, download software.
- IV. One SIM card interface
- V. Charging Interface.
- VI. Supports Bluetooth Function.

### 3] Sensors:

#### • Metal sensor:-

Metal sensor is used in this system to detect the entry of any metallic hazardous body in the remote vehicle. It also checks out if any arms & animation is carried by passenger.

#### • IR sensor:-

A simple Infra Red Sensor is used to detect the tyre conditions of vehicle. The IR sensor is to be fitted near to the tyre facing to ground. If tyre is full with air, a particular distance is maintained from the ground and which indicates tyre conditions are ok. If the air content is low then the distance between tyre and ground would be lowered. After a particular level at a very low distance, it can be said that tyre is punctured. This signal is sent to the micro controller and tyre puncture is detected.

#### • Pressure sensor:-

Pressure sensor is generally used to sense high pressures over the different platforms. Here in this system pressure sensor plays the crucial role in the accident detection of vehicle. Generally Pressure sensors costs more and to cover all the area of the vehicle, number of sensors may be required. That may increase the cost. To reduce the cost here in this project simple switches are used. These switches are normally open switches. When any external body gets hammered over the vehicle then internal switches attached to that particular section gets pressed and we can say that the accident has occurred. This signal is sent to the microcontroller and accident is detected.

#### • Temperature sensor:-

Temperature sensor is used to monitor the vehicle engine condition while travelling through remote areas. Wrong engine conditions may harm the vehicle seriously and can cause critical accidents. So it is very important to sense the vehicle engine conditions. To sense this, LM35 or thermistor, can be used. These temperature sensors are set at a particular temperature level above which it shows bad engine condition. So that particular signal is sent to the microcontroller and High temperature is detected.

#### • Fuel sensor:-

Fuel sensor is used to check the fuel level of vehicle over the long routs. It may be helpful to reduce the malfunctioning taking place in public transport services. A wide range of level sensor measurement systems are made available for

addressing the various parameters such as a wide range of applications, high-accuracy needs, and system installation requirements and practices. Any of these sensors can be easily used and fuel level can be monitored. So that particular signal is sent to microcontroller and Low Fuel level is detected.

• **Lock key switch:-**

Lock key switch is the precautionary facility provided in this system. This facility allows avoiding of extreme level anti human activities like hijacks. Lock key switch locks the ignition whenever required. It is used to activate/deactivate the ignition.

**4] Voice messenger:**

In this circuit voice recorder/playback IC is used for example APR 9600 voice IC. APR9600 is a low-cost high performance sound record/replay IC incorporating flash analogue storage technique. Recorded sound is retained even after power supply is removed from the module. The replayed sound exhibits high quality with a low noise level. Sampling rate for a 60 second recording period is 4.2 kHz that gives a sound record/replay bandwidth of 20Hz to 2.1 kHz. However, by changing an oscillation resistor, a sampling rate as high as 8.0 kHz can be achieved. This shortens the total length of sound recording to 32 seconds. Total sound recording time can be varied from 32 seconds to 60 seconds by changing the value of a single resistor. The IC can operate in one of two modes: serial mode and parallel mode.

**5] Power supply requirement:**

The whole system can be run over very low power. Power supply required is 12v dc/2A maximum.

**6] LCD:**

A simple Liquid Crystal Display is used in this transmitter section. This LCD can be configured to provide the information about vehicle performance parameters. For example 16\*2 lines LCD is used to monitor the conditions of vehicle.

ii) **Block diagram of Receiver section**

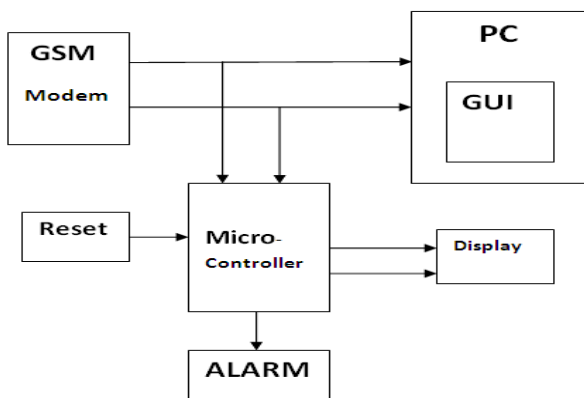

Fig.2 Receiver

**1] MCU:**

The Receiver section mainly contains the microcontroller which has a role to encode the received SMS and process it as per further requirement. The SMS contains latitude, longitude and the type of fault in the vehicle. These three parameters are separated and sent to the LCD and Computer. The microcontroller required here can be 89c52 or 89s52 etc.

**2] GSM modem:**

Receiver section works over this part i.e. GSM modem means Global System for Mobiles. This modem requires a SIM card which receives the SMS from transmitter vehicle side. These messages are sent to the microcontroller for encoding. Here in this project we can use SIM 300 GSM module.

**3] LCD:**

Receiver section requires the simple Liquid Crystal Display which is used to display the location messages in the form of latitude and longitude as well as the faults occurred at the vehicle side. The Alarm is also interfaced with the microcontroller which is an indicator of faults. Alarm is activated when fault SMS is received by GSM module.

**4] GUI:**

GUI i.e. Graphical User Interface is used as the visual interface between receiver section and user. This is used to simplify the tracking of remote vehicle. This also allows to maintain all records of each and every location and faults through which vehicle has gone. This is very important and user friendly part of whole system and also may attract public transport service providers.

**Interfacing Figures**

**Transmitter section**

This Circuit diagram consists of microcontroller 89s52 which is interfaced with 5 sensors at port 1. 16\*2LCD is connected to port 0 with 8 data pins. GSM module is connected at serial interface of microcontroller.

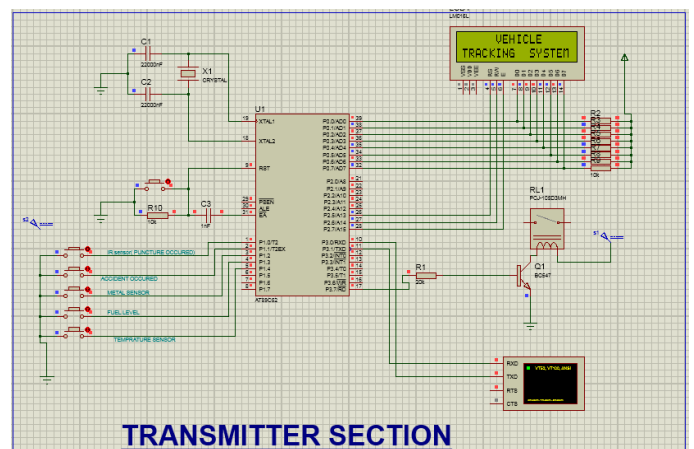

Fig.3 Circuit Diagram of Transmitter Section

## Receiver Section

Receiver section is equipped with GSM module, LCD and alarm. The GUI is available on computer which is connected through USB interface. LCD is connected at port0. Alarm is connected at port1 and GSM module is connect at serial port of microcontroller.

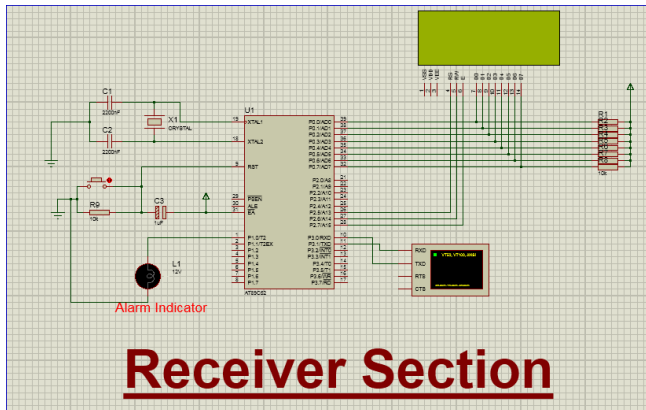

Fig.4 Circuit diagram of Receiver section

## Fault Tracking through GUI

This system mainly focuses on faults detection of remote travelling vehicle in order to provide security in the every prospect to passengers. To simplify this process to service providers, Graphical User Interface has come into picture. The receiver section which is available at office section must be connected to the computer through USB interface.

Microcontroller of receiver section encodes SMS got from transmitter and separates it into latitude, longitude and fault. This separated data is sent to serial port through USB interface.

### GUI (Graphical User Interface)

The simplified graphical User Interface is designed here by using Visual Studio 2010. This interface includes

#### -Simple Application Format

Due to which any non-technical person can easily access data without failure.

#### -Authentication

This allows the information access to the respective authorized persons only as this application has made secure with Username & Password.

Following figure shows the application front page which is username and password secured. The security of this application can be increased with some changes in code. We can add number of attempts for authentication. We can also lock the application for unauthorized access for some time.



Fig.5 GUI Authentication Page

#### -Real Time Data

After Authentication, Application gets connected to hardware through com port and remote vehicle data is made available with running date and time.

#### -Faults tracking

If there is any fault detected with remote vehicle then that would be suddenly available on this application along with location, date, time and type of fault.

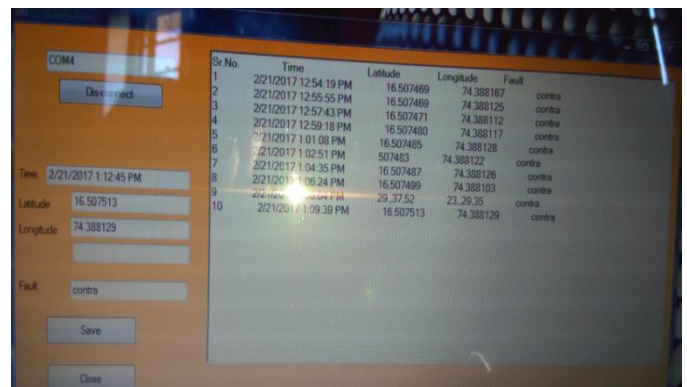

Fig.6 GUI information Page

#### -Record Maintenance

Application provides an extra facility to maintain these records of vehicle in the list format if required. By clicking 'Save' button, the available list will be saved in the notepad format over given path.

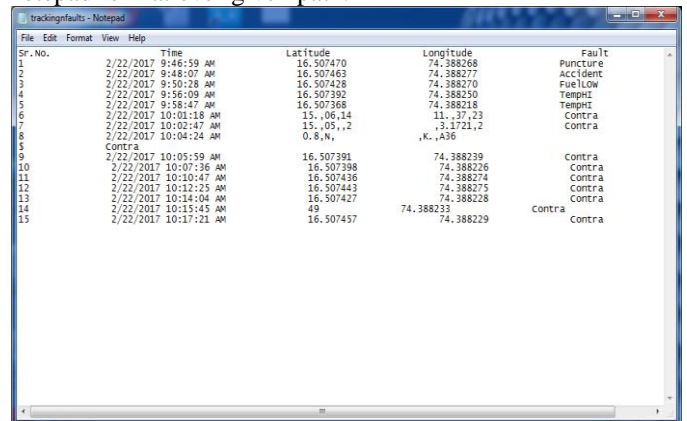

Fig.7 GUI Record maintenance through notepad

## Continuous Mapping

This system also provides facility to track the perfect location of remote vehicle on real maps of that particular area. Mapping is made available by using the code of MATLAB. The code uses the information available over com port which comes through serial interface USB. Code undergoes through following steps for mapping.

- Receives data from serial port.
- Separates fault and location information.
- Separates latitude and longitude.
- Accesses the Google map through web.
- Plots the respective longitude & latitude over Google Map.
- Shows the corresponding location pointer by red dot on map.
- Continuously scans serial port information at every 10<sup>th</sup> second.
- Displays the new location through received data by red dot on Google map.

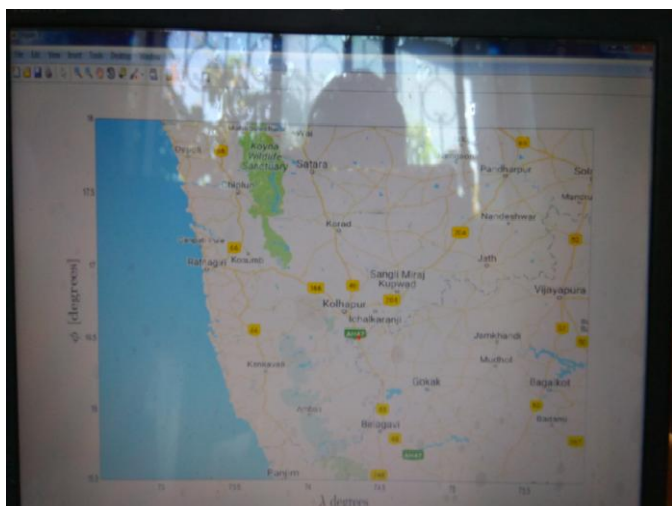

Fig.8 Vehicle mapping

## Conclusion

This project probably overcomes most of the bottlenecks of private as well as public transport services. This system supports multitasking and can be easily configured further for number of vehicles over a large scale. Inclusion of real time data tracking simplifies all other social issues in front of service providers. Graphical User interface is the best solution for malfunctioning in large scale transportation systems. It also provides better facility to maintain accurate records of vehicle information with date, time and locations which can be easily stored for years. Continuous mapping over web Google maps assures reliability of Project. This Mapping may also be useful while dealing with critical situations like accidents or other natural calamities to get early helps to victims. By all this discussion, this project can easily claims as a better solution of public transport systems.

## References

- [1] Fleischer P.B., Nelson A.Y., Sowah, R.A. Bremang, A. "Design and development of GPS/GSM based vehicle tracking and alert system for commercial inter-city buses" Adaptive Science & Technology (ICAST), 2012 IEEE 4th International Conference on Digital Object Identifier:10.1109/ICASTEch.2012.6381056 Publication Year: 2012
- [2] Farooq U., ulHaq T., Amar M., Asad M.U., Iqbal A. "GPS-GSM Integration for Enhancing Public Transportation Management Services" Computer Engineering and Applications (ICCEA), 2010 Second International Conference on Volume: 2 Digital Object Identifier:10.1109/ICCEA.2010.183 Publication Year: 2010
- [3] Brown, A. "A low cost vehicle location and tracking system" Position Location and Navigation Symposium, 1992. Record. 500 Years After Columbus - Navigation Challenges of Tomorrow. IEEE PLANS '92., IEEE Digital Object Identifier:10.1109/PLANS.1992.185896 Publication Year: 1992
- [4] Young, K.-K.D. ; Yong QuanOu; Jun Tao Feng ; Zhi Liang Ou ; LunHuiCai ; Cheng, K.K.M.; KamOnHo, J.; Tsang, T.T.M. "Automated navigation and mobile vehicle control using wireless sensor network technology" Industrial Technology, 2008. ICIT 2008. IEEE International Conference on Digital Object Identifier:10.1109/ICIT.2008.4608536 Publication Year: 2008
- [5] Ananthanarayanan N. "Intelligent vehicle monitoring system using wireless communication" Advances in Technology and Engineering (ICATE), 2013 International Conference on Digital Object Identifier: 10.1109/ICAdTE.2013.6524722 Publication Year: 2013.